



APEX DYNAMICS, INC.



**High Precision
Rack and Pinion**

Main Features

High Precision
High Loading
High Speed
Low Noise
Long Life-Time
Quick Delivery

APEX is the **ONLY ONE** manufacturer worldwide who produces rack strictly according to specifications regarding :

Geometrical Tolerance of all Dimensions
Defined Straightness, Parallelism and Perpendicularity
Helical Angle and Pressure Angle with Tolerance
Defined Surface Roughness of Teeth
Defined Hardness and Thickness of the Hardened Layer on the Teeth.

APEX is also the **ONLY ONE** of the world leading brands who designs and produces rack, pinion and gearbox by its own, and provides well coordinated high-quality transmission sets to fulfill different industrial requirements.

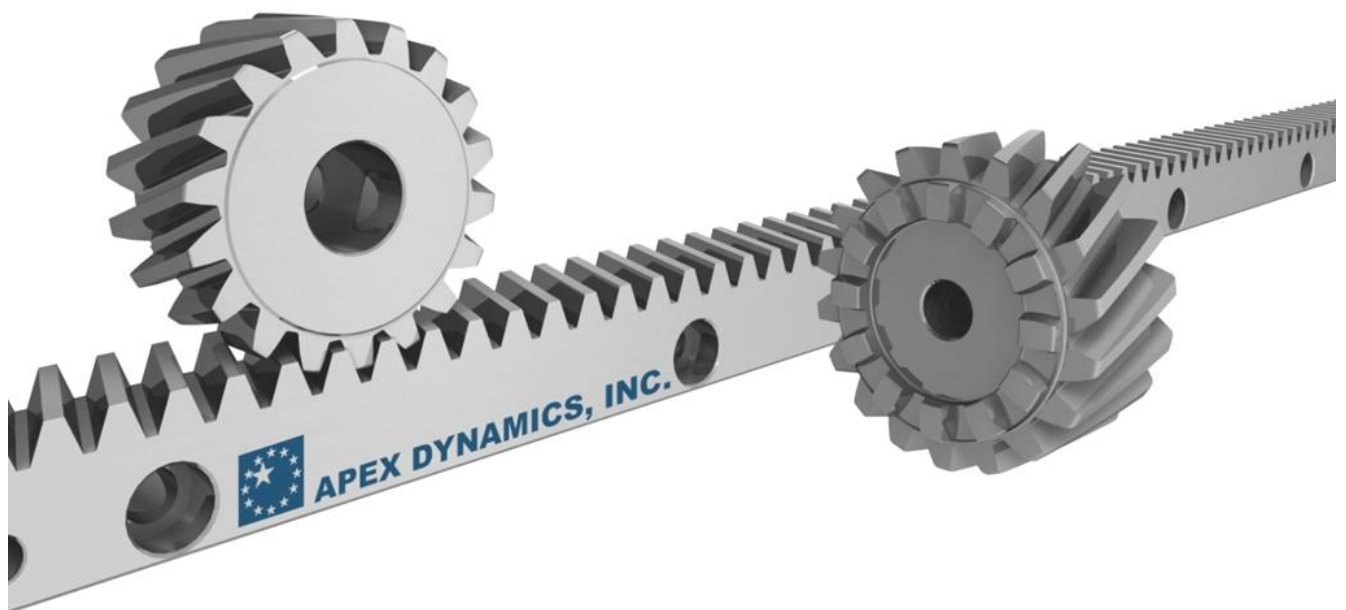

Content

Requirement of High-Precision Rack	Page	3
Declaration of Tolerance		7
Induction Hardening for Rack		11
Heat-Treatment for Pinion		12
Rack Quality and Application		13
Rack Order Code		14
Rack with Helical Teeth		15
Rack with Helical Teeth (with Linear-Guide Interface, 90° Type)		29
Rack with Helical Teeth (with Linear-Guide Interface, 180° Type)		30
APEX High Precision Pinion		31
APEX Pinion with Curvic Plate		32
Pinion Order Code		33
Pinion with Helical Teeth (Curvic Plate / EN ISO 9409-I-A)		34
Pinion with Helical Teeth (Welded Plate / EN ISO 9409-I-A)		39
Pinion with Helical Teeth (Teeth Plate / EN ISO 9409-I-A)		45
Pinion with Helical Teeth (DIN 5480 / Spline)		50
Pinion with Helical Teeth (Keyway for APEX AF / KF / AE / PII-Series)		52
Pinion with Helical Teeth (Keyway)		54
Pinion with Helical Teeth (Long Shaft with Keyway for Hollow-Shaft)		61
Pinion with Helical Teeth (Long Shaft without Keyway for Hollow-Shaft)		63
Rack with Straight Teeth		65
Rack with Straight Teeth (with Linear-Guide Interface, 90° Type)		78
Rack with Straight Teeth (with Linear-Guide Interface, 180° Type)		79
Pinion with Straight Teeth (Curvic Plate / EN ISO 9409-I-A)		80
Pinion with Straight Teeth (Welded Plate / EN ISO 9409-I-A)		85
Pinion with Straight Teeth (Keyway)		91
Pinion with Straight Teeth (Keyway / CP System)		100
Pinion with Straight Teeth (Long Shaft with Keyway for Hollow-Shaft)		102
Pinion with Straight Teeth (Long Shaft without Keyway for Hollow-Shaft)		104
Accessory		106
Rack Calculation and Selection		108

Requirement of High-Precision Rack

Requirement and Reason	Technology needed
<p>Good Straightness, Less Torsion</p> <ul style="list-style-type: none"> • Influence the accuracy of pressure angle, helical angle and pitch error, hence Influence the gear coupling with pinion. • To avoid re-straightening work after long-term stock due to slow release of internal tension. 	<ul style="list-style-type: none"> ➤ Heat-treatment ➤ Straightening ➤ Machining on all sides ➤ Teeth milling and grinding ➤ Teeth induction hardening

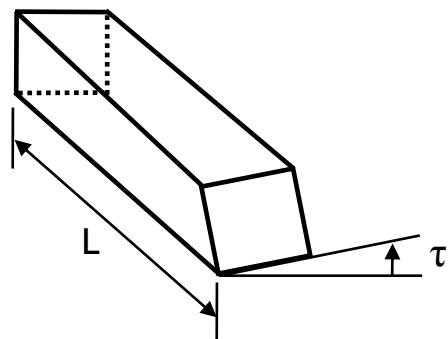
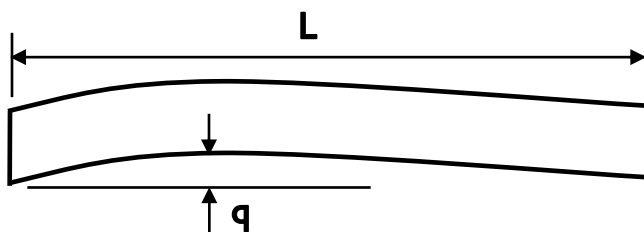

Requirement and Reason	Technology needed
<p>Accurate Pressure Angle α and Helical Angle β</p> <ul style="list-style-type: none"> • Optimizing gear-coupling with pinion • Optimizing transmission of torque or feed force • For high speed, low noise, less wearing, longer life-time 	<ul style="list-style-type: none"> ➤ Heat-treatment ➤ Straightening ➤ Machining on all sides ➤ Teeth milling and grinding ➤ Teeth induction hardening

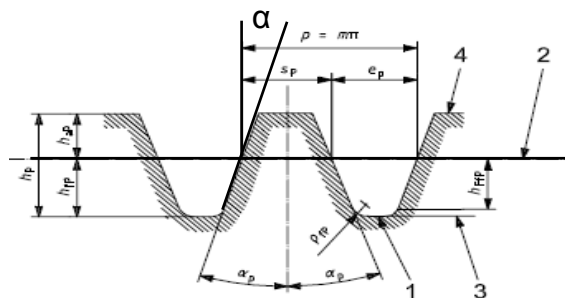
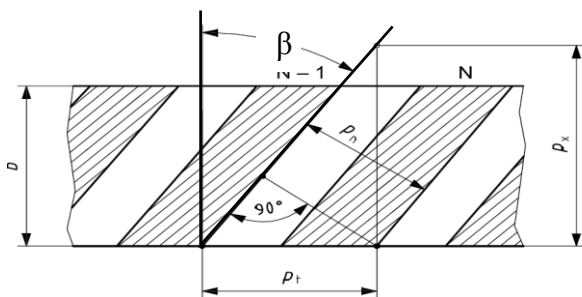
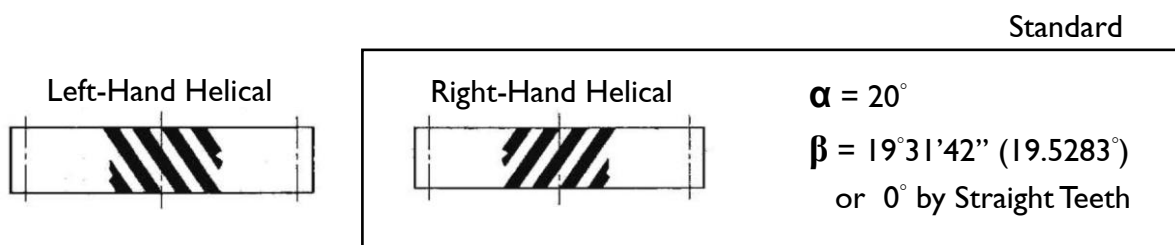

Requirement and Reason	Technology needed
Accurate Over-Pin Height H <ul style="list-style-type: none"> • A measure of accuracy of teeth profile • Optimizing gear-coupling with pinion • Influence on backlash between rack and pinion 	<ul style="list-style-type: none"> ➤ Heat-treatment ➤ Straightening ➤ Machining on all sides ➤ Teeth milling and grinding ➤ Teeth induction hardening

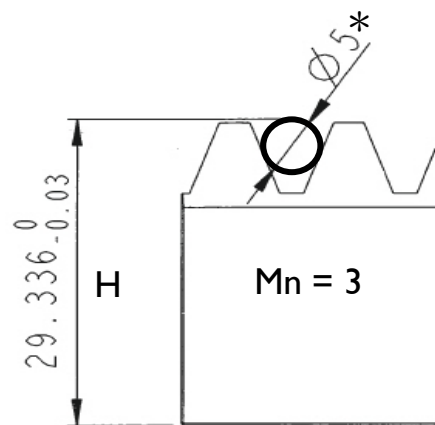

* Pin Diameter depending on Mn.

Requirement and Reason	Technology needed
Low Single Pitch Error Es / Low Total Pitch Error Et <ul style="list-style-type: none"> • Optimizing gear-coupling with pinion • Low noise, less wearing, longer life-time • High positioning accuracy • Influence on backlash 	<ul style="list-style-type: none"> ➤ Heat-treatment ➤ Straightening ➤ Machining on all sides ➤ Teeth milling and grinding ➤ Teeth induction hardening

- Pitch = $\pi \times$ Module No.
- Total Pitch Error Et is to be measured between the first and the last tooth of a rack.

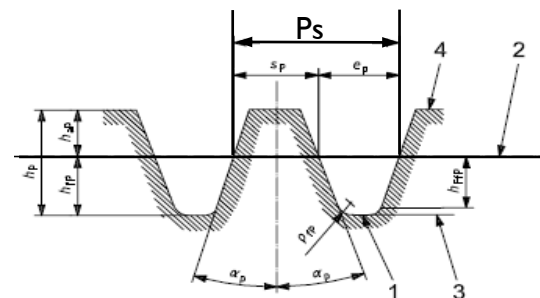
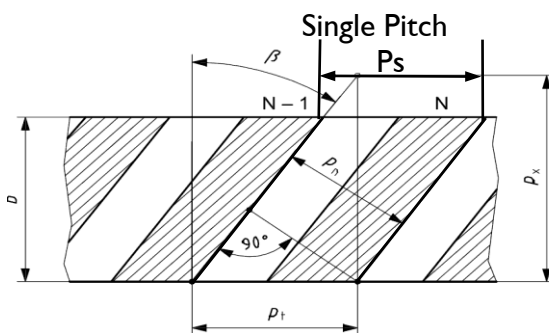

Requirement of High-Precision Rack

Requirement and Reason	Technology needed
Rigidity / Material Hardness <ul style="list-style-type: none"> • No deformation during gear coupling with Pinion • High strength of rack / High strength of teeth • Transmission of high torque or high feed force • High speed, less wearing, long life-time 	<ul style="list-style-type: none"> ➤ Heat-treatment ➤ Teeth induction hardening

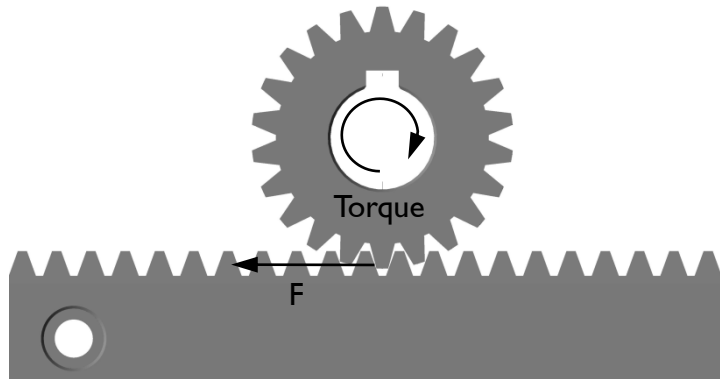

Requirement and Reason	Technology needed
High Surface Hardness <ul style="list-style-type: none"> • High strength of rack / High strength of teeth • Transmission of high torque or high feed force • High wearing resistance 	<ul style="list-style-type: none"> ➤ Heat-treatment ➤ Induction hardening ➤ Teeth grinding
Thickness of Hardened-Layer <ul style="list-style-type: none"> • Preserve accuracy and long life-time 	
Symmetry of Hardened-Layer on teeth profiles <ul style="list-style-type: none"> • Preserve accuracy and long life-time in both moving directions on the rack 	



Qualified induction hardening and teeth grinding



Bad induction hardening and / or bad teeth grinding

Requirement and Reason	Technology needed
<p>Low Remaining Magnet</p> <ul style="list-style-type: none"> • Prevent adhesion of particles between the rack and pinion which leads to pitting and damage the teeth profile. • Smooth running • Preserve accuracy and long life-time 	<p>➤ Degauss device</p>

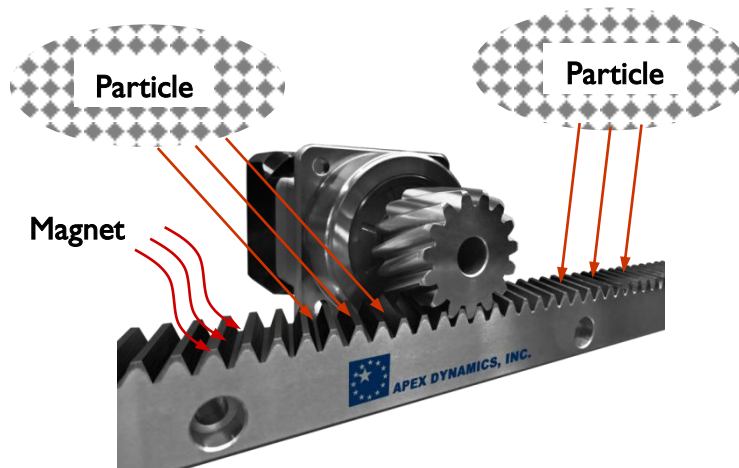

APEX rack has been degaussed until 10 ± 3 Gauss!

Requirement and Reason	Technology needed
<p>Magnetic Crack Inspection</p> <ul style="list-style-type: none"> • Preserve accuracy • Guarantee of long life-time 	<p>➤ Magnetic crack inspection device</p>

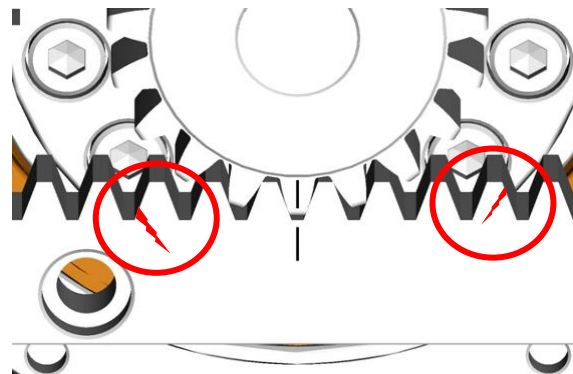
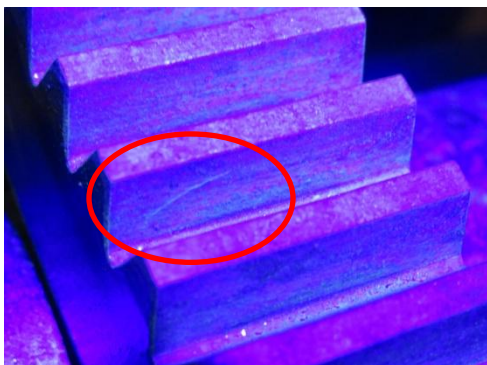

APEX rack has been checked by Magnetic Crack Inspection Device!

Declaration of Tolerance

Parallelism and Perpendicularity

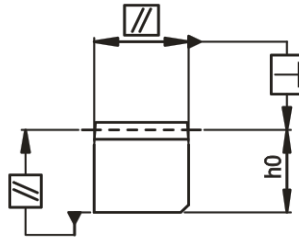

Quality	Q4 ~ Q5		Q6		Q6M / Q6C		Q8 / Q9		Q10	
> 10 ~ 16	0.004	0.006	0.006	0.01	0.015	0.025	0.025	0.04	0.04	0.06
> 16 ~ 25	0.005	0.008	0.008	0.012	0.02	0.03	0.03	0.05	0.05	0.08
> 25 ~ 40	0.006	0.01	0.01	0.015	0.025	0.04	0.04	0.06	0.06	0.1
> 40 ~ 63	0.008	0.012	0.012	0.02	0.03	0.05	0.05	0.08	0.08	0.12
> 63 ~ 100	0.01	0.015	0.015	0.025	0.04	0.06	0.06	0.1	0.1	0.15
> 100 ~ 160	0.012	0.02	0.02	0.03	0.05	0.08	0.08	0.12	0.12	0.2

Straightness *

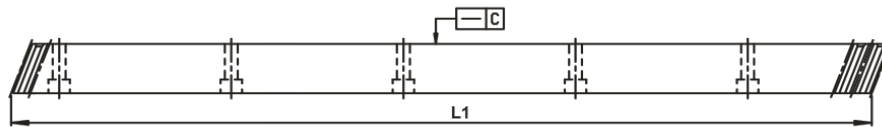

Quality	Q4 ~ Q6		Q6M / Q6C		Q8 ~ Q9		Q10	
	Fixed	Free	Fixed	Free	Fixed	Free	Fixed	Free
M1~M2, milled	-	-	0.04	0.45	0.05	0.45	0.08	0.5
M1~M2, ground	0.02	0.4	-	-	-	-	-	-
M3~M6, milled	-	-	0.04	0.45	0.05	0.45	0.08	0.5
M3~M6, ground	0.02	0.3	-	-	-	-	-	-
M8~M12, milled	-	-	0.04	0.45	0.05	0.45	0.08	0.5
M8~M12, ground	0.02	0.25	-	-	-	-	-	-

* Straightness is given either in a free situation (Free) or on a certified flat surface in a fixed mounted situation (Fixed). By the Free-case, the rack is lying on the certified surface with its teeth at the side.

Surface Roughness

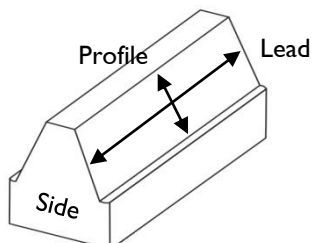

Quality	Q 4 ~ Q 6	Q 6M / Q 6C	Q 8 ~ Q 9	Q 10
Lead	Ra ≤ 0.5	Ra ≤ 0.5	Ra ≤ 1.0	Ra ≤ 1.6
Profile	Ra ≤ 1.0	Ra ≤ 1.0	Ra ≤ 3.0	Ra ≤ 6.3
Side	Ra ≤ 0.8	Ra ≤ 2.0	Ra ≤ 2.0	Ra ≤ 2.0

Tolerance of Rack Teeth

APEX declares clearly all the tolerances of rack dimension and geometry, beginning from the design through out the manufacturing.

Pressure Angle Deviation

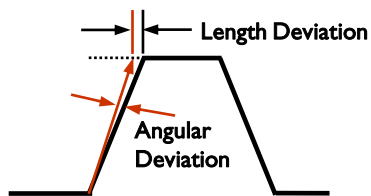

Height Deviation

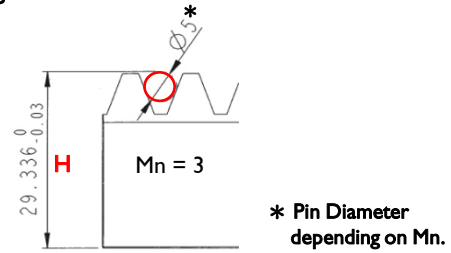

Helical Angle Deviation

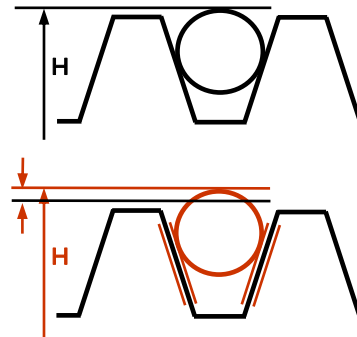
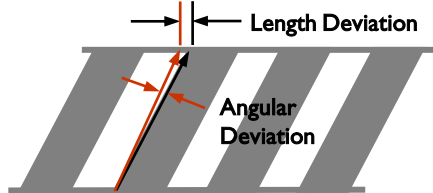

Single Pitch Error

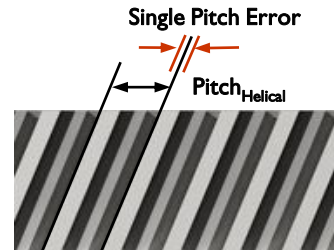
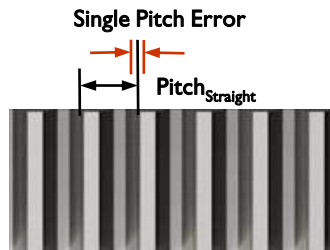

Total Pitch Error

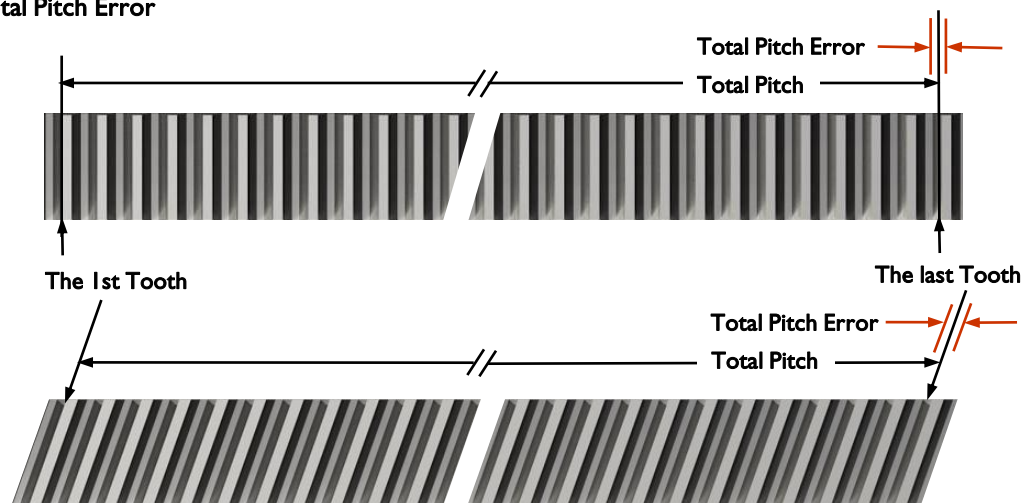

Declaration of Tolerance

Precision / Tolerance of Rack Teeth

Module No.	Deviation	Q4	Q5H / Q5	Q6 / Q6M / Q6C	Q8H / Q8	Q9	Q10
1	Pressure Angle Deviation (μm)	≤ 4	≤ 6	≤ 8	≤ 16	≤ 23	≤ 36
	Helical Angle Deviation (μm)	≤ 6	≤ 7	≤ 9	≤ 18	≤ 28	≤ 45
	Over-Pin Height Deviation (μm)	0	0	0	0	0	0
		- 19	- 21	- 30	- 66	-87	- 124
	Single Pitch Error (I) (μm)	≤ 4.5	≤ 6	≤ 8	≤ 16	≤ 23	≤ 37
Total Pitch Error (I) (μm)	≤ 17	≤ 24	≤ 33	≤ 65	≤ 91	≤ 146	

Module No.	Deviation	Q4	Q5H / Q5	Q6 / Q6M / Q6C	Q8H / Q8	Q9	Q10
1.5	Pressure Angle Deviation (μm)	≤ 4	≤ 6	≤ 8	≤ 16	≤ 23	≤ 36
	Helical Angle Deviation (μm)	≤ 6	≤ 7	≤ 9	≤ 18	≤ 28	≤ 45
	Over-Pin Height Deviation (μm)	0	0	0	0	0	0
		- 19	- 21	- 30	- 66	-87	- 124
	Single Pitch Error (I) (μm)	≤ 4.5	≤ 6	≤ 8	≤ 16	≤ 23	≤ 37
Total Pitch Error (I) (μm)	≤ 17	≤ 24	≤ 34	≤ 66	≤ 91	≤ 148	

Module No.	Deviation	Q4	Q5H / Q5	Q6 / Q6M / Q6C	Q8H / Q8	Q9	Q10
2	Pressure Angle Deviation (μm)	≤ 4	≤ 6	≤ 8	≤ 16	≤ 23	≤ 36
	Helical Angle Deviation (μm)	≤ 6.5	≤ 8	≤ 10	≤ 20	≤ 32	≤ 52
	Over-Pin Height Deviation (μm)	0	0	0	0	0	0
		- 19	- 20	- 30	- 66	-87	- 123
	Single Pitch Error (I) (μm)	≤ 4.5	≤ 6	≤ 8	≤ 16	≤ 23	≤ 37
Total Pitch Error (I) (μm)	≤ 17	≤ 24	≤ 34	≤ 66	≤ 91	≤ 148	

Module No.	Deviation	Q4	Q5H / Q5	Q6 / Q6M / Q6C	Q8H / Q8	Q9	Q10
2.5	Pressure Angle Deviation (μm)	≤ 5	≤ 7	≤ 10	≤ 20	≤ 28	≤ 45
	Helical Angle Deviation (μm)	≤ 6.5	≤ 8	≤ 10	≤ 20	≤ 32	≤ 52
	Over-Pin Height Deviation (μm)	0	0	0	0	0	0
		- 19	- 21	- 30	- 66	-87	- 124
	Single Pitch Error (I) (μm)	≤ 4.5	≤ 6	≤ 9	≤ 18	≤ 25	≤ 39
Total Pitch Error (I) (μm)	≤ 19	≤ 26	≤ 36	≤ 72	≤ 100	≤ 160	

Module No.	Deviation	Q4	Q5H / Q5 / Q5 ⁺	Q6 / Q6M / Q6C	Q8H / Q8	Q9	Q10
3	Pressure Angle Deviation (μm)	≤ 5	≤ 7	≤ 10	≤ 20	≤ 28	≤ 45
	Helical Angle Deviation (μm)	≤ 6.5	≤ 8	≤ 10	≤ 20	≤ 32	≤ 52
	Over-Pin Height Deviation (μm)	0	0	0	0	0	0
		- 19	- 21	- 30	- 66	-87	- 124
	Single Pitch Error (I) (μm)	≤ 4.5	≤ 6	≤ 9	≤ 18	≤ 25	≤ 39
Total Pitch Error (I) (μm)	≤ 19	≤ 26	≤ 37	≤ 72	≤ 101	≤ 162	

Module No.	Deviation	Q4	Q5H / Q5 / Q5 ⁺	Q6 / Q6M / Q6C	Q8H / Q8	Q9	Q10
4	Pressure Angle Deviation (μm)	≤ 7	≤ 9	≤ 13	≤ 25	≤ 35	≤ 56
	Helical Angle Deviation (μm)	≤ 6.5	≤ 8	≤ 10	≤ 20	≤ 32	≤ 52
	Over-Pin Height Deviation (μm)	0	0	0	0	0	0
		- 19	- 21	- 30	- 66	- 66	- 124
	Single Pitch Error (I) (μm)	≤ 5	≤ 7	≤ 10	≤ 19	≤ 18	≤ 43
Total Pitch Error (I) (μm)	≤ 20	≤ 28	≤ 40	≤ 78	≤ 72	≤ 175	

(I) For helical and straight teeth, basing on the nominal length 1000 mm.
Straightness is to measure on a certified flat surface in a fix mounted situation.

Precision / Tolerance of Rack Teeth

Module No.	Deviation	Q4	Q5H / Q5 / Q5 ⁺	Q6 / Q6M	Q8H / Q8	Q9	Q10
5	Pressure Angle Deviation (μm)	≤ 7	≤ 9	≤ 13	≤ 25	≤ 35	≤ 56
	Helical Angle Deviation (μm)	≤ 8	≤ 10	≤ 13	≤ 25	≤ 41	≤ 65
	Over-Pin Height Deviation (μm)	0	0	0	0	0	0
		-19	-21	-30	-66	-87	-124
	Single Pitch Error (I) (μm)	≤ 5	≤ 7	≤ 10	≤ 19	≤ 27	≤ 43
Total Pitch Error (I) (μm)	≤ 20	≤ 28	≤ 40	≤ 78	≤ 109	≤ 175	

Module No.	Deviation	Q4	Q5H / Q5 / Q5 ⁺	Q6 / Q6M	Q8H / Q8	Q9	Q10
6	Pressure Angle Deviation (μm)	≤ 7	≤ 9	≤ 13	≤ 25	≤ 35	≤ 56
	Helical Angle Deviation (μm)	≤ 8	≤ 10	≤ 13	≤ 25	≤ 41	≤ 65
	Over-Pin Height Deviation (μm)	0	0	0	0	0	0
		-19	-21	-30	-66	-87	-124
	Single Pitch Error (I) (μm)	≤ 5	≤ 7	≤ 10	≤ 19	≤ 27	≤ 43
Total Pitch Error (I) (μm)	≤ 20	≤ 28	≤ 40	≤ 78	≤ 109	≤ 175	

Module No.	Deviation	Q4	Q5H / Q5	Q6 / Q6M	Q8H / Q8	Q9	Q10
8	Pressure Angle Deviation (μm)	≤ 8	≤ 12	≤ 16	≤ 32	≤ 45	≤ 72
	Helical Angle Deviation (μm)	≤ 8	≤ 10	≤ 13	≤ 25	≤ 41	≤ 65
	Over-Pin Height Deviation (μm)	0	0	0	0	0	0
		-20	-21	-31	-66	-87	-124
	Single Pitch Error (I) (μm)	≤ 5.5	≤ 8	≤ 11	≤ 22	≤ 31	≤ 49
Total Pitch Error (I) (μm)	≤ 22	≤ 31	≤ 43	≤ 84	≤ 118	≤ 188	

Module No.	Deviation	Q4	Q5H / Q5	Q6 / Q6M	Q8H / Q8	Q9	Q10
10	Pressure Angle Deviation (μm)	≤ 8	≤ 12	≤ 16	≤ 32	≤ 45	≤ 72
	Helical Angle Deviation (μm)	≤ 8	≤ 10	≤ 13	≤ 25	≤ 41	≤ 65
	Over-Pin Height Deviation (μm)	0	0	0	0	0	0
		-20	-21	-31	-66	-87	-124
	Single Pitch Error (I) (μm)	≤ 5.5	≤ 8	≤ 11	≤ 22	≤ 31	≤ 49
Total Pitch Error (I) (μm)	≤ 22	≤ 31	≤ 43	≤ 84	≤ 118	≤ 188	

Module No.	Deviation	Q4	Q5H / Q5	Q6 / Q6M	Q8H / Q8	Q9	Q10
12	Pressure Angle Deviation (μm)	≤ 11	≤ 15	≤ 21	≤ 42	≤ 58	≤ 93
	Helical Angle Deviation (μm)	≤ 10	≤ 13	≤ 16	≤ 32	≤ 51	≤ 82
	Over-Pin Height Deviation (μm)	0	0	0	0	0	0
		-20	-21	-31	-66	-87	-124
	Single Pitch Error (I) (μm)	≤ 7	≤ 10	≤ 13	≤ 26	≤ 37	≤ 59
Total Pitch Error (I) (μm)	≤ 23	≤ 33	≤ 46	≤ 90	≤ 126	≤ 202	

- (I) For helical and straight teeth, basing on the nominal length 1000 mm.
Straightness is to measure on a certified flat surface in a fix mounted situation.

Induction Hardening for Rack

Scanning Induction Hardening

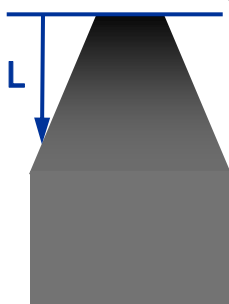

Tooth-by-Tooth Induction Hardening

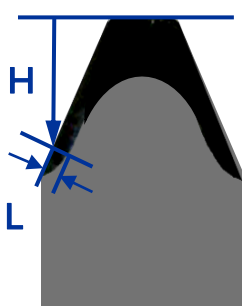

Carburized Induction Hardening

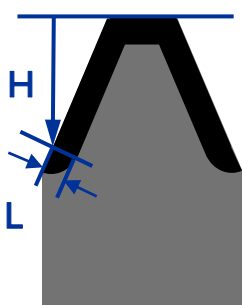

Induction Hardening		
Surface Hardness	Hardness by Effective Thickness L	
550 ± 40 HV	440 ± 32 HV	
Module No.	H	L
1	-	1.75
1.5	-	2.63
1.591 (Pitch 5)	-	2.79
2	-	3.5
2.5	-	4.38
3	-	4.8
3.183 (Pitch 10)	-	5.09

Module No.	H	L
4	7.2	0.3
4.244 (Pitch 13.33)	7.64	0.3
5	9	0.3
6	10.8	0.3
8	14.4	0.3
10	18	0.3
12	21.6	0.3

Carburized Induction Hardening		
Surface Hardness	Hardness by Effective Thickness L	
640 ~ 720 HV	515 ~ 580 HV	
Module No.	H	L
2	3.5	0.4
2.5	4.38	0.48
3	4.8	0.55
4	6	0.68
5	10	0.88
6	12	1.03
8	16	0.91
10	20	0.87

Note : In the cross-section, the effective thickness can be guaranteed over 80% in the middle of the teeth width.

Heat-Treatment for Pinion

Material : Alloy Steel

Heat-Treatment : Case Hardening

Teeth : Ground

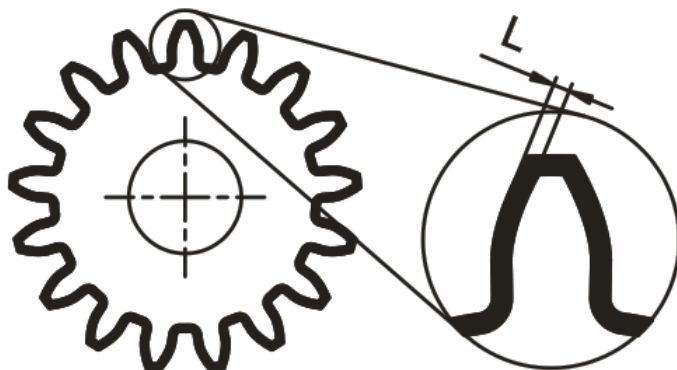

Case Hardening	
Surface Hardness	Hardness by Effective Thickness L
640 ~ 720 HV	515 ~ 580 HV

(The surface hardness is measured at the pitch circle.)

Mn	L (in mm)
1.5	0.3
1.591 (Pitch 5)	0.3
2	0.3
2.5	0.38
3	0.45
3.183 (Pitch 10)	0.48
4	0.6
4.244 (Pitch 13.33)	0.64
5	0.75
6	0.9
8	1.2
10	1.5

Rack Quality and Application

Quality	Module	Total Pitch Error (μm / 1000mm)	Tooth Thickness Tolerance (μm)	Application
4	5 ~ 12	20 ~ 23	-13 ~ 0	<ul style="list-style-type: none"> • Measurement equipment • Certification laboratory • High-end machine tools with electrical Preload
5H	2 ~ 10	24 ~ 31	-15 ~ 0	<ul style="list-style-type: none"> • For the installation without back support • High rigidity / high torque • Multi-pinion application • To replace lager module-no.
5	2 ~ 12	24 ~ 33	-15 ~ 0	<ul style="list-style-type: none"> • High-end machine tools • Lifting axis • Multi-pinion application
5 ⁺	3 ~ 6	26 ~ 28	-15 ~ 0	<ul style="list-style-type: none"> • High-end machine tools • Multi-pinion application
6	1 ~ 12	33 ~ 46	-22 ~ 0	<ul style="list-style-type: none"> • Machine tools • Water-/ laser-/ plasma-cutting machines • Portal machine center • Tube bending machine • Woodworking machine • Combination with linear guide
6M	2 ~ 10	34 ~ 43	-22 ~ 0	<ul style="list-style-type: none"> • Combination with linear guide • Automatic loading system
6C	1 ~ 4	29 ~ 40	-22 ~ 0	<ul style="list-style-type: none"> • Suitable for high precision positioning, low loading, low working cycle
8H	2 ~ 4	66 ~ 78	-48 ~ 0	<ul style="list-style-type: none"> • Welding machine • Robots • Automatic loading system • Linear axis with low load feed
8	1.5 ~ 12	66 ~ 90	-48 ~ 0	<ul style="list-style-type: none"> • Welding machine • Robots • Automatic loading system • Linear axis with low load feed
9	1 ~ 6	91 ~ 109	-63 ~ 0	<ul style="list-style-type: none"> • Stainless • Food industry / pharmaceutical industry • Clean room application
10	1 ~ 12	146 ~ 202	-90 ~ 0	<ul style="list-style-type: none"> • Lifting axis • Automatic loading system • Robots • Outdoor application

Rack Order Code

Example : 02 06 R 100 C I 0 ()

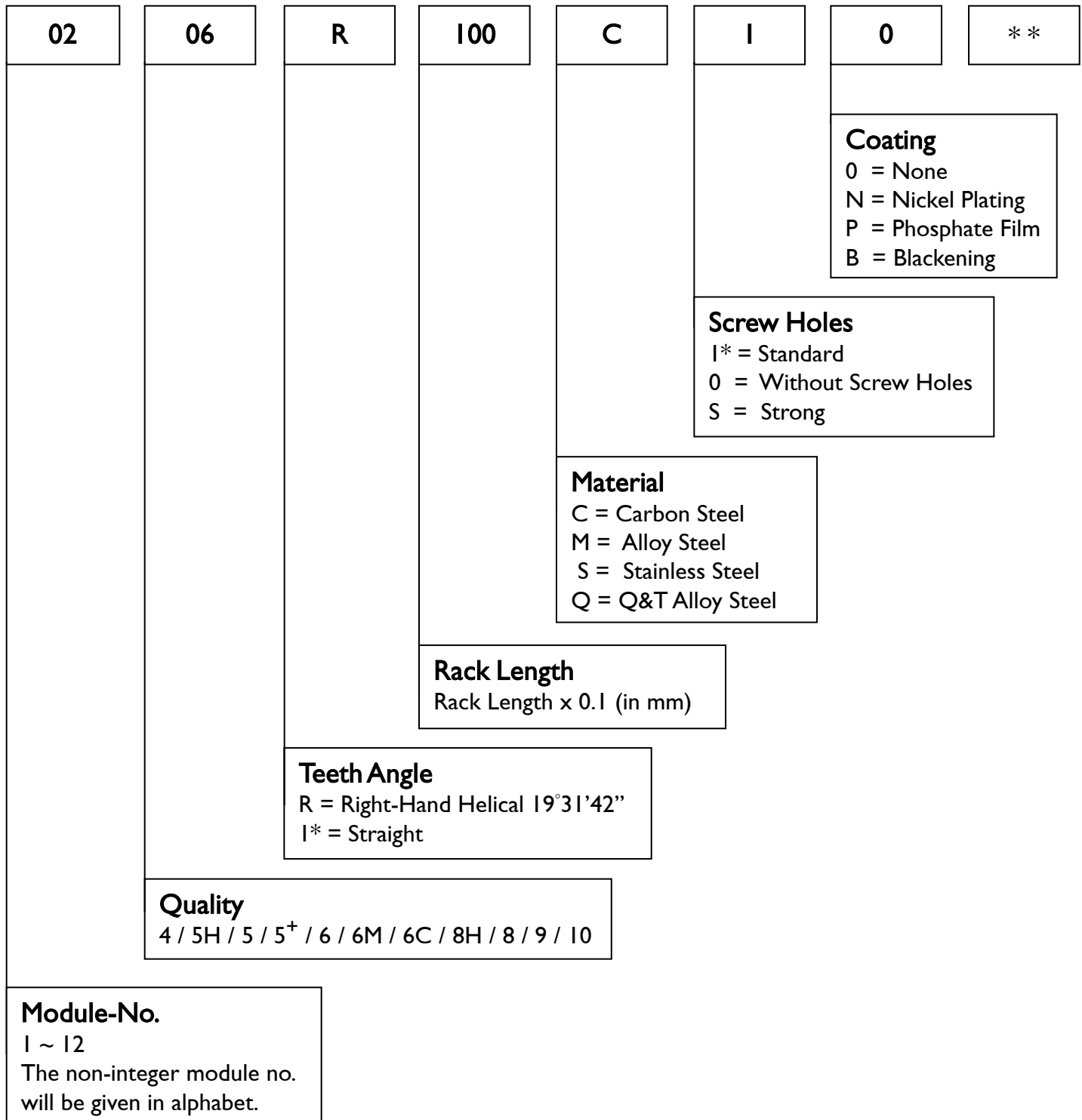

* I = " one "

** A1 = For Linear-Guide Interface, 90° Type
 A2 = For Linear-Guide Interface, 180° Type

Rack with Helical Teeth

Quality 4 / Carbon Steel
 Tooth Thickness Tolerance : -13 ~ 0 μm
 Right-Hand Helical Teeth
 Teeth Induction Hardened and Ground
 All Sides Ground

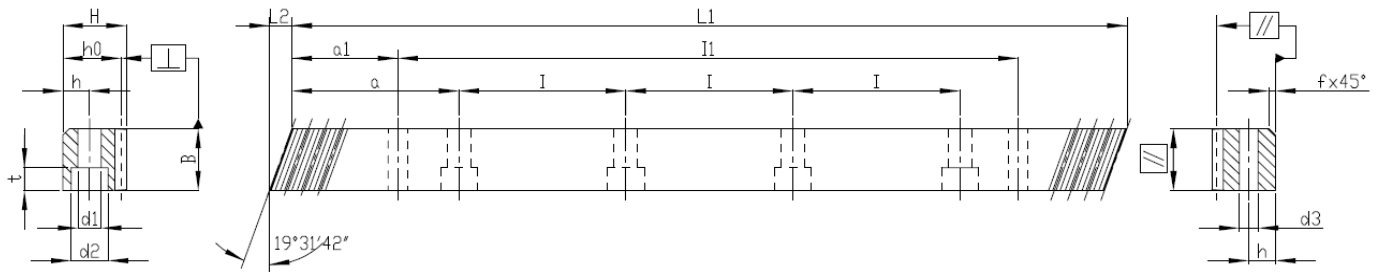

Mn	Pt ⁽¹⁾	L1	L2	Teeth No.	B	H	ho	f	a	I	Hole No.	h	d1	d2	t	a1	l1	d3	f _p ⁽²⁾	F _p ⁽³⁾	Order Code *
5	16.66669	1000	17.4	60	49	39	34	3	62.5	125	8	12	14	20	13	37.5	925	11.7	0.005	0.020	0504R100C10
6	20.00003	1000	20.9	50	59	49	43	3	62.5	125	8	16	18	26	17	37.5	925	15.7	0.005	0.020	0604R100C10
8	26.66671	960	28.0	36	79	79	71	3	60.0	120	8	25	22	33	21	120.0	720	19.7	0.006	0.022	0804R100C10
10	33.33339	1000	35.1	30	99	99	89	3	62.5	125	8	32	33	48	32	125.0	750	19.7	0.006	0.022	1004R100C10
12	40.00006	1000	42.6	25	120	120	108	3	40.0	125	8	40	39	58	38	102.5	750	19.7	0.007	0.023	1204R100C10

(1) Teeth Pitch Pt = Module $\times \pi / \cos (19^{\circ}31'42'')$ (2) fp = Single Pitch Error (3) Fp = Total Pitch Error

* For all models APEX also provides Rack without screw-holes. By ordering please change the 2nd last order-code position from "1" to "0". Please also refer to page 14.

Quality 5H / Alloy Steel
 Tooth Thickness Tolerance : -15 ~ 0 μm
 Right-Hand Helical Teeth
 Material Case-Hardened
 Teeth Ground and all Sides Ground

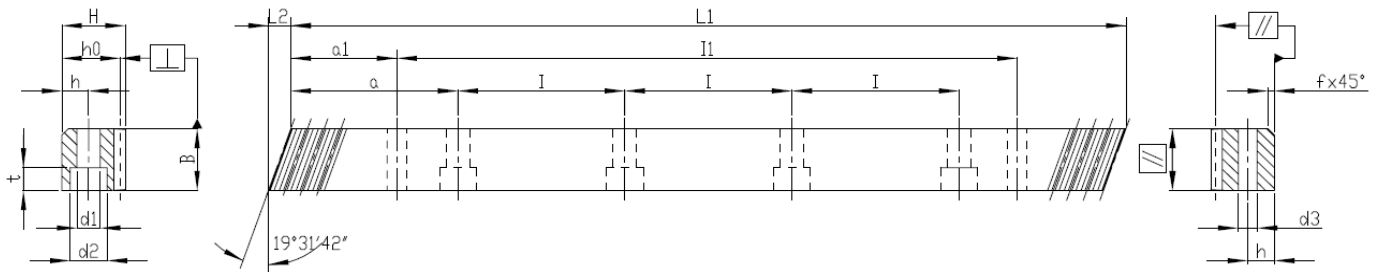

Mn	Pt ⁽¹⁾	L1	L2	Teeth No.	B	H	ho	f	a	l	Hole No.	h	d1	d2	t	a1	l1	d3	fp ⁽²⁾	Fp ⁽³⁾	Order Code *
2	6.66668	1000	8.5	150	24	24	22	2	62.5	125	8	9	10	15	9	31.7	936.6	7.7	0.006	0.024	025HR100M10
3	10.00002	1000	10.3	100	29	29	26	2	62.5	125	8	10	12	17.5	11	27.5	945.0	11.7	0.006	0.026	035HR100M10
4	13.33335	1000	13.8	75	39	39	35	3	62.5	125	8	13	16	23	15	30.0	940.0	15.7	0.007	0.028	045HR100M10
5	16.66669	1000	17.4	60	49	49	44	3	62.5	125	8	15	18	26	17	34.5	931.0	15.7	0.007	0.028	055HR100M10
6	20.00003	1000	20.9	50	59	59	53	3	62.5	125	8	20	22	33	21	97.5	805.0	19.7	0.007	0.028	065HR100M10
8	26.66671	960	28.0	36	79	79	71	3	60.0	120	8	25	26	39	25	120.0	720.0	19.7	0.008	0.031	085HR100M10
10	33.33339	1000	35.1	30	99	99	89	3	40.0	125	8	32	39	58	38	102.5	750.0	19.7	0.008	0.031	105HR100M10

(1) Teeth Pitch Pt = Module $\times \pi / \cos (19^{\circ}31'42'')$ (2) fp = Single Pitch Error (3) Fp = Total Pitch Error

* For all models APEX also provides Rack without screw-holes. By ordering please change the 2nd last order-code position from "I" to "0". Please also refer to page 14.

Especially for the application without back-support.

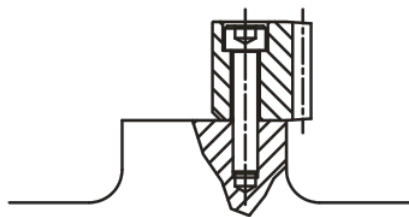

Without alignment / back-support

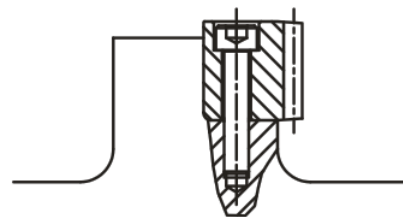

With alignment / back-support

Rack with Helical Teeth

Quality 5 / Alloy Steel
 Tooth Thickness Tolerance : -15 ~ 0 μm
 Right-Hand Helical Teeth
 Material Carburized, Induction Hardened
 Teeth Ground and all Sides Ground

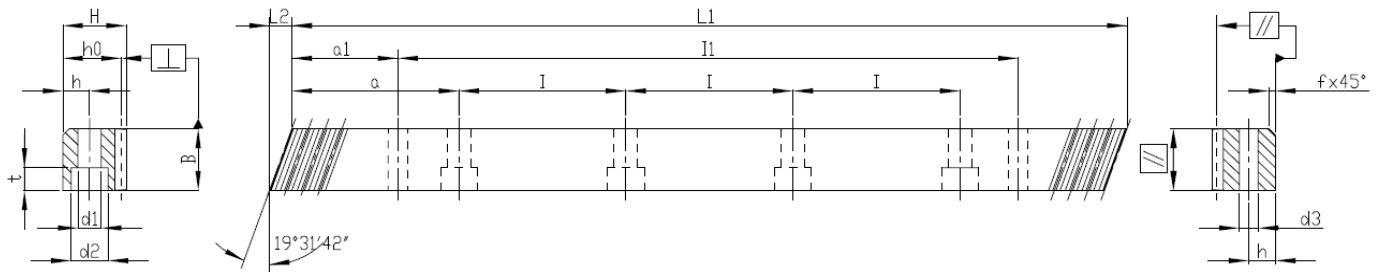

Mn	P _t ⁽¹⁾	L1	L2	Teeth No.	B	H	h ₀	f	a	I	Hole No.	h	d1	d2	t	a1	I1	d3	f _p ⁽²⁾	F _p ⁽³⁾	Order Code*
2	6.66668	500	8.5	75	24	24	22	2	62.5	125	4	8	7	11	7	31.7	436.6	5.7	0.0055	0.021	0205R050M10
2	6.66668	1000	8.5	150	24	24	22	2	62.5	125	8	8	7	11	7	31.7	936.6	5.7	0.006	0.024	0205R100M10
2	6.66668	1246.67	8.5	187	24	24	22	2	62.5	125	10	8	7	11	7	31.7	1183.3	5.7	0.006	0.024	0205R125M10
2	6.66668	1500	8.5	225	24	24	22	2	62.5	125	12	8	7	11	7	31.7	1436.6	5.7	0.006	0.024	0205R150M10
2	6.66668	1746.67	8.5	262	24	24	22	2	62.5	125	14	8	7	11	7	31.7	1683.3	5.7	0.006	0.024	0205R175M10
2	6.66668	2000	8.5	300	24	24	22	2	62.5	125	16	8	7	11	7	31.7	1936.6	5.7	0.007	0.027	0205R200M10
2.5	8.33335	500	10.3	60	29	29	26.5	2	62.5	125	4	9	10	15	9	35	430	7.7	0.006	0.023	2J05R050M10
2.5	8.33335	1000	10.3	120	29	29	26.5	2	62.5	125	8	9	10	15	9	35	930	7.7	0.006	0.026	2J05R100M10
2.5	8.33335	1250	10.3	150	29	29	26.5	2	62.5	125	10	9	10	15	9	35	1180	7.7	0.006	0.026	2J05R125M10
2.5	8.33335	1500	10.3	180	29	29	26.5	2	62.5	125	12	9	10	15	9	35	1430	7.7	0.006	0.026	2J05R150M10
2.5	8.33335	1750	10.3	210	29	29	26.5	2	62.5	125	14	9	10	15	9	35	1680	7.7	0.006	0.026	2J05R175M10
2.5	8.33335	2000	10.3	240	29	29	26.5	2	62.5	125	16	9	10	15	9	35	1930	7.7	0.007	0.029	2J05R200M10
3	10.00002	500	10.3	50	29	29	26	2	62.5	125	4	9	10	15	9	35	430	7.7	0.006	0.023	0305R050M10
3	10.00002	1000	10.3	100	29	29	26	2	62.5	125	8	9	10	15	9	35	930	7.7	0.006	0.026	0305R100M10
3	10.00002	1250	10.3	125	29	29	26	2	62.5	125	10	9	10	15	9	35	1180	7.7	0.006	0.026	0305R125M10
3	10.00002	1500	10.3	150	29	29	26	2	62.5	125	12	9	10	15	9	35	1430	7.7	0.006	0.026	0305R150M10
3	10.00002	1750	10.3	175	29	29	26	2	62.5	125	14	9	10	15	9	35	1680	7.7	0.006	0.026	0305R175M10
3	10.00002	2000	10.3	200	29	29	26	2	62.5	125	16	9	10	15	9	35	1930	7.7	0.007	0.03	0305R200M10

(1) Teeth Pitch Pt = Module $\times \pi / \cos (19^{\circ}31'42'')$ (2) f_p = Single Pitch Error (3) F_p = Total Pitch Error

* For all models APEX also provides Rack without screw-holes. By ordering please change the 2nd last order-code position from "1" to "0". Please also refer to page 14.

Quality 5 / Carbon Steel
 Tooth Thickness Tolerance : -15 ~ 0 μm
 Right-Hand Helical Teeth
 Teeth Induction Hardened and Ground
 All Sides Ground

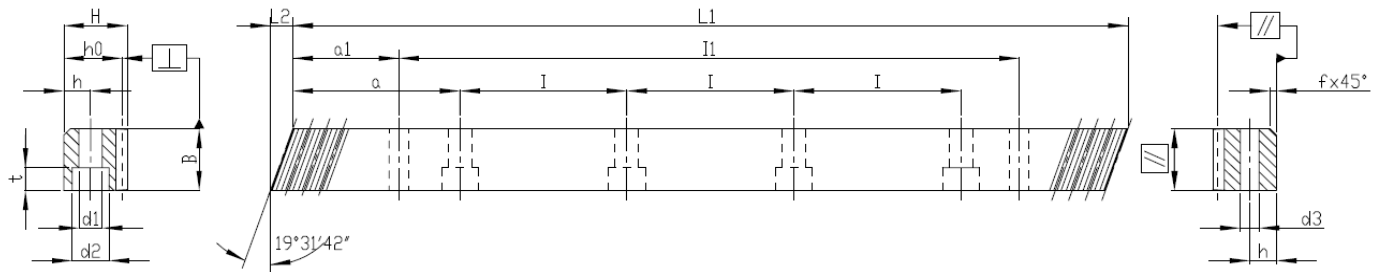

Mn	Pt ⁽¹⁾	L1	L2	Teeth No.	B	H	ho	f	a	I	Hole No.	h	d1	d2	t	a1	II	d3	fp ⁽²⁾	Fp ⁽³⁾	Order Code *
4	13.33335	506.67	13.8	38	39	39	35	3	62.5	125	4	12	10	15	9	33.3	433	7.7	0.007	0.025	0405R050C10
4	13.33335	1000	13.8	75	39	39	35	3	62.5	125	8	12	10	15	9	33.3	933.4	7.7	0.007	0.028	0405R100C10
4	13.33335	1000	13.8	75	39	39	35	3	62.5	125	8	12	14	20	13	33.3	933.4	11.7	0.007	0.028	0405R100CS0
4	13.33335	1253.34	13.8	94	39	39	35	3	62.5	125	10	12	10	15	9	33.3	1186.7	7.7	0.007	0.028	0405R125C10
4	13.33335	1506.67	13.8	113	39	39	35	3	62.5	125	12	12	10	15	9	33.3	1433.4	7.7	0.007	0.028	0405R150C10
4	13.33335	1506.67	13.8	113	39	39	35	3	62.5	125	12	12	14	20	13	33.3	1433.4	11.7	0.007	0.028	0405R150CS0
4	13.33335	1760	13.8	132	39	39	35	3	62.5	125	14	12	10	15	9	33.3	1693.4	7.7	0.007	0.028	0405R175C10
4	13.33335	2000	13.8	150	39	39	35	3	62.5	125	16	12	10	15	9	33.3	1933.4	7.7	0.008	0.032	0405R200C10
4	13.33335	2000	13.8	150	39	39	35	3	62.5	125	16	12	14	20	13	33.3	1933.4	11.7	0.008	0.032	0405R200CS0
5	16.66669	1000	17.4	60	49	39	34	3	62.5	125	8	12	14	20	13	37.5	925	11.7	0.007	0.028	0505R100C10
6	20.00003	1000	20.9	50	59	49	43	3	62.5	125	8	16	18	26	17	37.5	925	15.7	0.007	0.028	0605R100C10
8	26.66671	960	28	36	79	79	71	3	60	120	8	25	22	33	21	120	720	19.7	0.008	0.031	0805R100C10
10	33.33339	1000	35.1	30	99	99	89	3	62.5	125	8	32	33	48	32	125	750	19.7	0.008	0.031	1005R100C10
12	40.00006	1000	42.6	25	120	120	108	3	40	125	8	40	39	58	38	102.5	750	19.7	0.01	0.033	1205R100C10

(1) Teeth Pitch Pt = Module x π / cos (19°31'42") (2) fp = Single Pitch Error (3) Fp = Total Pitch Error

* For all models APEX also provides Rack without screw-holes. By ordering please change the 2nd last order-code position from "1" to "0". Please also refer to page 14.

Quality 5⁺ / Carbon Steel
 Tooth Thickness Tolerance : -15 ~ 0 μm
 Right-Hand Helical Teeth
 Teeth Induction Hardened and Ground
 All Sides Ground

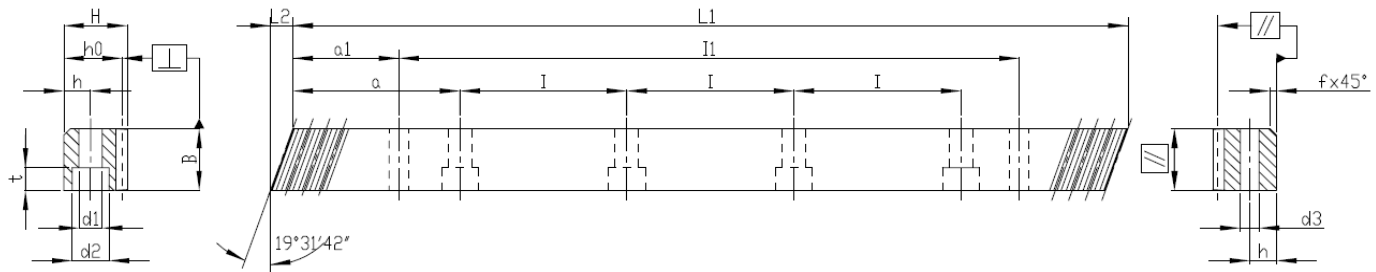

Mn	P _t ⁽¹⁾	L1	L2	Teeth No.	B	H	h ₀	f	a	l	Hole No.	h	d1	d2	t	a1	l1	d3	f _p ⁽²⁾	F _p ⁽³⁾	Order Code *
3	10.00002	500	10.3	50	29	29	26	2	62.5	62.5	7	9	10	15	9	35	430	7.7	0.006	0.023	0305R050CX0
3	10.00002	1000	10.3	100	29	29	26	2	62.5	62.5	15	9	10	15	9	35	930	7.7	0.006	0.026	0305R100CX0
3	10.00002	2000	10.3	200	29	29	26	2	62.5	62.5	31	9	10	15	9	35	1930	7.7	0.007	0.03	0305R200CX0
4	13.33335	506.67	13.8	38	39	39	35	3	62.5	62.5	7	12	12	18	11	33.3	433	9.7	0.007	0.025	0405R050CX0
4	13.33335	1000	13.8	75	39	39	35	3	62.5	62.5	15	12	12	18	11	33.3	933.4	9.7	0.007	0.028	0405R100CX0
4	13.33335	2000	13.8	150	39	39	35	3	62.5	62.5	31	12	12	18	11	33.3	1933.4	9.7	0.008	0.032	0405R200CX0
5	16.66669	500	17.4	30	49	39	34	3	62.5	62.5	7	12	14	20	13	37.5	425	11.7	0.007	0.025	0505R050CX0
5	16.66669	1000	17.4	60	49	39	34	3	62.5	62.5	15	12	14	20	13	37.5	925	11.7	0.007	0.028	0505R100CX0
5	16.66669	2000	17.4	120	49	39	34	3	62.5	62.5	31	12	14	20	13	37.5	1925	11.7	0.008	0.032	0505R200CX0
6	20.00003	500	20.9	25	59	49	43	3	62.5	62.5	7	16	18	26	17	37.5	425	15.7	0.007	0.025	0605R050CX0
6	20.00003	1000	20.9	50	59	49	43	3	62.5	62.5	15	16	18	26	17	37.5	925	15.7	0.007	0.028	0605R100CX0
6	20.00003	2000	20.9	100	59	49	43	3	62.5	62.5	31	16	18	26	17	37.5	1925	15.7	0.008	0.032	0605R200CX0

(1) Teeth Pitch $P_t = \text{Module} \times \pi / \cos(19^\circ 31' 42'')$ (2) $f_p = \text{Single Pitch Error}$ (3) $F_p = \text{Total Pitch Error}$

Rack with Helical Teeth

Quality 6 / Carbon Steel
 Tooth Thickness Tolerance : -22 ~ 0 μm
 Right-Hand Helical Teeth
 Teeth Induction Hardened and Ground
 All Sides Ground

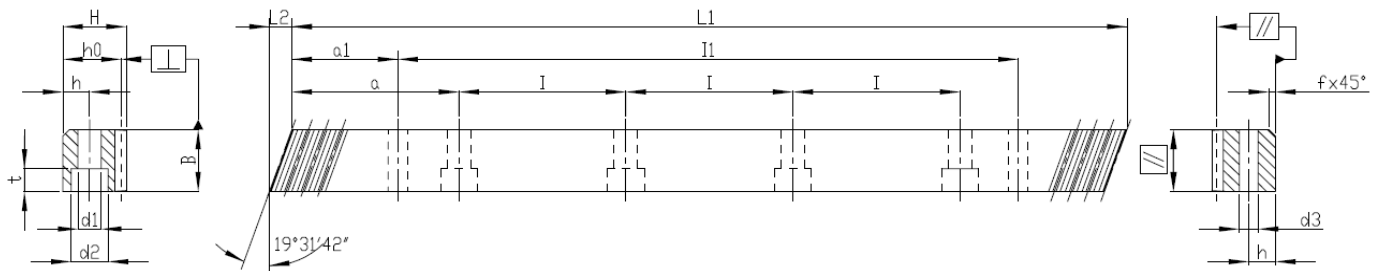

Mn	P _t ⁽¹⁾	L1	L2	Teeth No.	B	H	h ₀	f	a	I	Hole No.	h	d1	d2	t	a1	I1	d3	f _p ⁽²⁾	F _p ⁽³⁾	Order Code *
1	3.33334	500	5.3	150	15	15	14	2	62.5	125	4	6	5	8	5	30.3	439.4	5.7	0.008	0.029	0106R050C10
1	3.33334	1000	5.3	300	15	15	14	2	62.5	125	8	6	5	8	5	30.3	939.4	5.7	0.008	0.033	0106R100C10
1	3.33334	1500	5.3	450	15	15	14	2	62.5	125	12	6	5	8	5	30.3	1439.4	5.7	0.008	0.033	0106R150C10
1.5	5.00001	500	6.7	100	19	19	17.5	2	62.5	125	4	8	7	11	7	31.7	436.6	5.7	0.008	0.029	1J06R050C10
1.5	5.00001	1000	6.7	200	19	19	17.5	2	62.5	125	8	8	7	11	7	31.7	936.6	5.7	0.008	0.034	1J06R100C10
2	6.66668	500	8.5	75	24	24	22	2	62.5	125	4	8	7	11	7	31.7	436.6	5.7	0.008	0.029	0206R050C10
2	6.66668	1000	8.5	150	24	24	22	2	62.5	125	8	8	7	11	7	31.7	936.6	5.7	0.008	0.034	0206R100C10
2	6.66668	1246.67	8.5	187	24	24	22	2	62.5	125	10	8	7	11	7	31.7	1183.3	5.7	0.008	0.034	0206R125C10
2	6.66668	1500	8.5	225	24	24	22	2	62.5	125	12	8	7	11	7	31.7	1436.6	5.7	0.008	0.034	0206R150C10
2	6.66668	1746.67	8.5	262	24	24	22	2	62.5	125	14	8	7	11	7	31.7	1683.3	5.7	0.008	0.034	0206R175C10
2	6.66668	2000	8.5	300	24	24	22	2	62.5	125	16	8	7	11	7	31.7	1936.6	5.7	0.009	0.038	0206R200C10
2.5	8.33335	500	10.3	60	29	29	26.5	2	62.5	125	4	9	10	15	9	35	430	7.7	0.008	0.032	2J06R050C10
2.5	8.33335	1000	10.3	120	29	29	26.5	2	62.5	125	8	9	10	15	9	35	930	7.7	0.009	0.036	2J06R100C10
2.5	8.33335	1250	10.3	150	29	29	26.5	2	62.5	125	10	9	10	15	9	35	1180	7.7	0.009	0.036	2J06R125C10
2.5	8.33335	1500	10.3	180	29	29	26.5	2	62.5	125	12	9	10	15	9	35	1430	7.7	0.009	0.036	2J06R150C10
2.5	8.33335	1750	10.3	210	29	29	26.5	2	62.5	125	14	9	10	15	9	35	1680	7.7	0.009	0.036	2J06R175C10
2.5	8.33335	2000	10.3	240	29	29	26.5	2	62.5	125	16	9	10	15	9	35	1930	7.7	0.01	0.041	2J06R200C10
3	10.00002	500	10.3	50	29	29	26	2	62.5	125	4	9	10	15	9	35	430	7.7	0.008	0.032	0306R050C10
3	10.00002	1000	10.3	100	29	29	26	2	62.5	125	8	9	10	15	9	35	930	7.7	0.009	0.037	0306R100C10
3	10.00002	1250	10.3	125	29	29	26	2	62.5	125	10	9	10	15	9	35	1180	7.7	0.009	0.037	0306R125C10
3	10.00002	1500	10.3	150	29	29	26	2	62.5	125	12	9	10	15	9	35	1430	7.7	0.009	0.037	0306R150C10
3	10.00002	1750	10.3	175	29	29	26	2	62.5	125	14	9	10	15	9	35	1680	7.7	0.009	0.037	0306R175C10
3	10.00002	2000	10.3	200	29	29	26	2	62.5	125	16	9	10	15	9	35	1930	7.7	0.01	0.042	0306R200C10

(1) Teeth Pitch Pt = Module x π / cos (19°31'42") (2) f_p = Single Pitch Error (3) F_p = Total Pitch Error

* For all models APEX also provides Rack without screw-holes. By ordering please change the 2nd last order-code position from "1" to "0". Please also refer to page 14.

Rack with Helical Teeth

Quality 6 / Carbon Steel
 Tooth Thickness Tolerance : -22 ~ 0 μm
 Right-Hand Helical Teeth
 Teeth Induction Hardened and Ground
 All Sides Ground

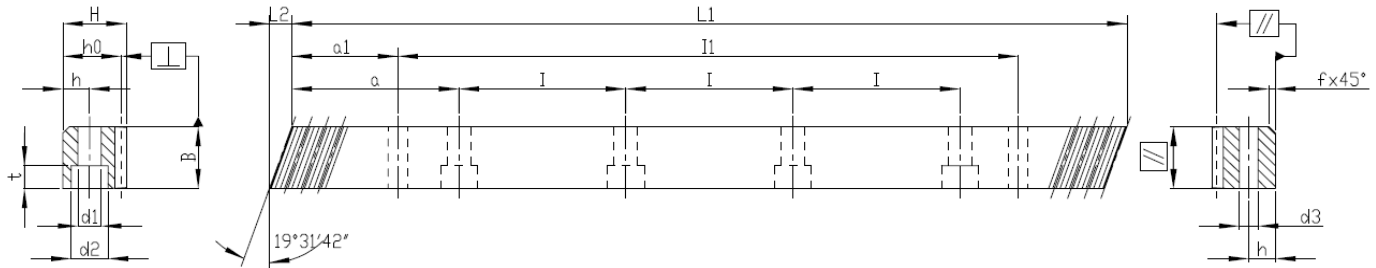

Mn	P _t ⁽¹⁾	L1	L2	Teeth No.	B	H	h ₀	f	a	I	Hole No.	h	d1	d2	t	a1	I1	d3	f _p ⁽²⁾	F _p ⁽³⁾	Order Code *
4	13.33335	506.67	13.8	38	39	39	35	3	62.5	125	4	12	10	15	9	33.3	433	7.7	0.009	0.034	0406R050C10
4	13.33335	506.67	13.8	38	39	39	35	3	62.5	125	4	12	14	20	13	33.3	433	11.7	0.009	0.034	0406R050CS0
4	13.33335	1000	13.8	75	39	39	35	3	62.5	125	8	12	10	15	9	33.3	933.4	7.7	0.01	0.04	0406R100C10
4	13.33335	1000	13.8	75	39	39	35	3	62.5	125	8	12	14	20	13	33.3	933.4	11.7	0.01	0.04	0406R100CS0
4	13.33335	1253.34	13.8	94	39	39	35	3	62.5	125	10	12	10	15	9	33.3	1186.7	7.7	0.01	0.04	0406R125C10
4	13.33335	1506.67	13.8	113	39	39	35	3	62.5	125	12	12	10	15	9	33.3	1433.4	7.7	0.01	0.04	0406R150C10
4	13.33335	1506.67	13.8	113	39	39	35	3	62.5	125	12	12	14	20	13	33.3	1433.4	11.7	0.01	0.04	0406R150CS0
4	13.33335	1760	13.8	132	39	39	35	3	62.5	125	14	12	10	15	9	33.3	1693.4	7.7	0.01	0.04	0406R175C10
4	13.33335	2000	13.8	150	39	39	35	3	62.5	125	16	12	10	15	9	33.3	1933.4	7.7	0.011	0.045	0406R200C10
4	13.33335	2000	13.8	150	39	39	35	3	62.5	125	16	12	14	20	13	33.3	1933.4	11.7	0.011	0.045	0406R200CS0
5	16.66669	500	17.4	30	49	39	34	3	62.5	125	4	12	14	20	13	37.5	425	11.7	0.009	0.034	0506R050C10
5	16.66669	1000	17.4	60	49	39	34	3	62.5	125	8	12	14	20	13	37.5	925	11.7	0.01	0.04	0506R100C10
5	16.66669	1250	17.4	75	49	39	34	3	62.5	125	10	12	14	20	13	37.5	1175	11.7	0.01	0.04	0506R125C10
5	16.66669	1500	17.4	90	49	39	34	3	62.5	125	12	12	14	20	13	37.5	1425	11.7	0.01	0.04	0506R150C10
5	16.66669	1750	17.4	105	49	39	34	3	62.5	125	14	12	14	20	13	37.5	1675	11.7	0.01	0.04	0506R175C10
5	16.66669	2000	17.4	120	49	39	34	3	62.5	125	16	12	14	20	13	37.5	1925	11.7	0.011	0.045	0506R200C10
6	20.00003	500	20.9	25	59	49	43	3	62.5	125	4	16	18	26	17	37.5	425	15.7	0.009	0.034	0606R050C10
6	20.00003	1000	20.9	50	59	49	43	3	62.5	125	8	16	18	26	17	37.5	925	15.7	0.01	0.04	0606R100C10
6	20.00003	1260	20.9	63	59	49	43	3	62.5	125	10	16	18	26	17	37.5	1185	15.7	0.01	0.04	0606R125C10
6	20.00003	1500	20.9	75	59	49	43	3	62.5	125	12	16	18	26	17	37.5	1425	15.7	0.01	0.04	0606R150C10
6	20.00003	1760	20.9	88	59	49	43	3	62.5	125	14	16	18	26	17	37.5	1685	15.7	0.01	0.04	0606R175C10
6	20.00003	2000	20.9	100	59	49	43	3	62.5	125	16	16	18	26	17	37.5	1925	15.7	0.011	0.045	0606R200C10
8	26.66671	480	28	18	79	79	71	3	60	120	4	25	22	33	21	120	240	19.7	0.011	0.037	0806R050C10
8	26.66671	960	28	36	79	79	71	3	60	120	8	25	22	33	21	120	720	19.7	0.011	0.043	0806R100C10
8	26.66671	1200	28	45	79	79	71	3	60	120	10	25	22	33	21	120	960	19.7	0.011	0.043	0806R125C10
8	26.66671	1440	28	54	79	79	71	3	60	120	12	25	22	33	21	120	1200	19.7	0.011	0.043	0806R150C10
8	26.66671	1680	28	63	79	79	71	3	60	120	14	25	22	33	21	120	1440	19.7	0.011	0.043	0806R175C10
8	26.66671	1920	28	72	79	79	71	3	60	120	16	25	22	33	21	120	1680	19.7	0.012	0.048	0806R200C10
10	33.33339	1000	35.1	30	99	99	89	3	62.5	125	8	32	33	48	32	125	750	19.7	0.011	0.043	1006R100C10
10	33.33339	1500	35.1	45	99	99	89	3	62.5	125	12	32	33	48	32	125	1250	19.7	0.011	0.043	1006R150C10
12	40.00006	1000	42.6	25	120	120	108	3	40	125	8	40	39	58	38	102.5	750	19.7	0.013	0.046	1206R100C10

(1) Teeth Pitch P_t = Module x π / cos (19°31'42") (2) f_p = Single Pitch Error (3) F_p = Total Pitch Error

* For all models APEX also provides Rack without screw-holes. By ordering please change the 2nd last order-code position from "1" to "0". Please also refer to page 14.

Quality 6M / Carbon Steel
 Tooth Thickness Tolerance : -22 ~ 0 μm
 Right-Hand Helical Teeth
 Teeth Induction Hardened and Ground
 All Sides Milled

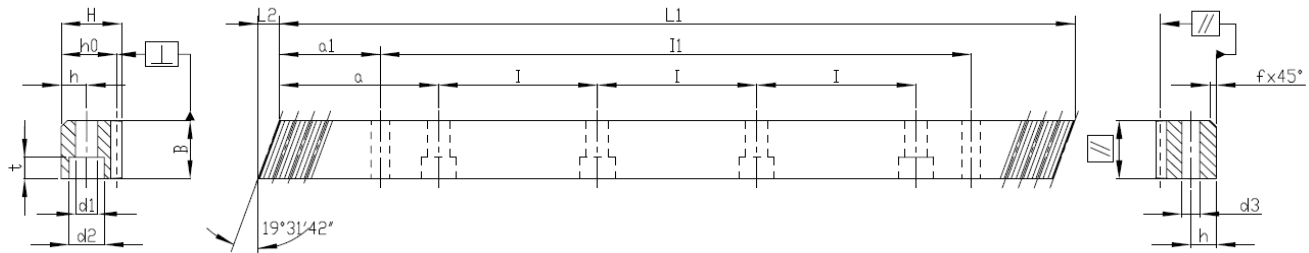

Mn	Pc ⁽¹⁾	L1	L2	Teeth No.	B	H	ho	f	a	l	Hole No.	h	dl	d2	t	al	ll	d3	fp ⁽²⁾	Fp ⁽³⁾	Order Code *
1	3.33334	500	5.3	150	15	15	14	2	62.5	125	4	6	5	8	5	30.3	439.4	5.7	0.008	0.029	016MR050C10
1	3.33334	1000	5.3	300	15	15	14	2	62.5	125	8	6	5	8	5	30.3	939.4	5.7	0.008	0.033	016MR100C10
1	3.33334	1500	5.3	450	15	15	14	2	62.5	125	12	6	5	8	5	30.3	1439.4	5.7	0.008	0.033	016MR150C10
1.5	5.00001	500	6.7	100	19	19	17.5	2	62.5	125	4	8	7	11	7	31.7	436.6	5.7	0.008	0.029	1J6MR050C10
1.5	5.00001	1000	6.7	200	19	19	17.5	2	62.5	125	8	8	7	11	7	31.7	936.6	5.7	0.008	0.034	1J6MR100C10
2	6.66668	500	8.5	75	24	24	22	2	62.5	125	4	8	7	11	7	31.7	436.6	5.7	0.008	0.029	026MR050C10
2	6.66668	1000	8.5	150	24	24	22	2	62.5	125	8	8	7	11	7	31.7	936.6	5.7	0.008	0.034	026MR100C10
2	6.66668	1246.67	8.5	187	24	24	22	2	62.5	125	10	8	7	11	7	31.7	1183.3	5.7	0.008	0.034	026MR125C10
2	6.66668	1500	8.5	225	24	24	22	2	62.5	125	12	8	7	11	7	31.7	1436.6	5.7	0.008	0.034	026MR150C10
2	6.66668	1746.67	8.5	262	24	24	22	2	62.5	125	14	8	7	11	7	31.7	1683.3	5.7	0.008	0.034	026MR175C10
2	6.66668	2000	8.5	300	24	24	22	2	62.5	125	16	8	7	11	7	31.7	1936.6	5.7	0.009	0.038	026MR200C10
2.5	8.33335	500	10.3	60	29	29	26.5	2	62.5	125	4	9	10	15	9	35	430	7.7	0.008	0.032	2J6MR050C10
2.5	8.33335	1000	10.3	120	29	29	26.5	2	62.5	125	8	9	10	15	9	35	930	7.7	0.009	0.036	2J6MR100C10
2.5	8.33335	1250	10.3	150	29	29	26.5	2	62.5	125	10	9	10	15	9	35	1180	7.7	0.009	0.036	2J6MR125C10
2.5	8.33335	1500	10.3	180	29	29	26.5	2	62.5	125	12	9	10	15	9	35	1430	7.7	0.009	0.036	2J6MR150C10
2.5	8.33335	1750	10.3	210	29	29	26.5	2	62.5	125	14	9	10	15	9	35	1680	7.7	0.009	0.036	2J6MR175C10
2.5	8.33335	2000	10.3	240	29	29	26.5	2	62.5	125	16	9	10	15	9	35	1930	7.7	0.01	0.041	2J6MR200C10
3	10.00002	500	10.3	50	29	29	26	2	62.5	125	4	9	10	15	9	35	430	7.7	0.008	0.032	036MR050C10
3	10.00002	1000	10.3	100	29	29	26	2	62.5	125	8	9	10	15	9	35	930	7.7	0.009	0.037	036MR100C10
3	10.00002	1250	10.3	125	29	29	26	2	62.5	125	10	9	10	15	9	35	1180	7.7	0.009	0.037	036MR125C10
3	10.00002	1500	10.3	150	29	29	26	2	62.5	125	12	9	10	15	9	35	1430	7.7	0.009	0.037	036MR150C10
3	10.00002	1750	10.3	175	29	29	26	2	62.5	125	14	9	10	15	9	35	1680	7.7	0.009	0.037	036MR175C10
3	10.00002	2000	10.3	200	29	29	26	2	62.5	125	16	9	10	15	9	35	1930	7.7	0.01	0.042	036MR200C10
4	13.33335	506.67	13.8	38	39	39	35	3	62.5	125	4	12	10	15	9	33.3	433	7.7	0.009	0.034	046MR050C10
4	13.33335	506.67	13.8	38	39	39	35	3	62.5	125	4	12	14	20	13	33.3	433	11.7	0.009	0.034	046MR050CS0
4	13.33335	1000	13.8	75	39	39	35	3	62.5	125	8	12	10	15	9	33.3	933.4	7.7	0.01	0.04	046MR100C10
4	13.33335	1000	13.8	75	39	39	35	3	62.5	125	8	12	14	20	13	33.3	933.4	11.7	0.01	0.04	046MR100CS0
4	13.33335	1253.34	13.8	94	39	39	35	3	62.5	125	10	12	10	15	9	33.3	1186.7	7.7	0.01	0.04	046MR125C10
4	13.33335	1506.67	13.8	113	39	39	35	3	62.5	125	12	12	10	15	9	33.3	1433.4	7.7	0.01	0.04	046MR150C10
4	13.33335	1760	13.8	132	39	39	35	3	62.5	125	14	12	10	15	9	33.3	1693.4	7.7	0.01	0.04	046MR175C10
4	13.33335	2000	13.8	150	39	39	35	3	62.5	125	16	12	10	15	9	33.3	1933.4	7.7	0.011	0.045	046MR200C10
5	16.66669	500	17.4	30	49	49	34	3	62.5	125	4	12	14	20	13	37.5	425	11.7	0.009	0.034	056MR050C10
5	16.66669	1000	17.4	60	49	49	34	3	62.5	125	8	12	14	20	13	37.5	925	11.7	0.01	0.04	056MR100C10
6	20.00003	500	20.9	25	59	59	43	3	62.5	125	4	16	18	26	17	37.5	425	15.7	0.009	0.034	066MR050C10
6	20.00003	1000	20.9	50	59	59	43	3	62.5	125	8	16	18	26	17	37.5	925	15.7	0.01	0.04	066MR100C10
8	26.66671	960	28	36	79	79	71	3	60	120	8	25	22	33	21	120	720	19.7	0.011	0.043	086MR100C10
10	33.33339	1000	35.1	30	99	99	89	3	62.5	125	8	32	33	48	32	125	750	19.7	0.011	0.043	106MR100C10

(1) Teeth Pitch Pt = Module x π / cos (19°31'42") (2) fp = Single Pitch Error (3) Fp = Total Pitch Error * Refer to the Page 22

Rack with Helical Teeth

Quality 6C / Carbon Steel
 Tooth Thickness Tolerance : -22 ~ 0 μm
 Right-Hand Helical Teeth
 Normalizing Heat-Treatment
 Teeth Ground, All Sides Milled

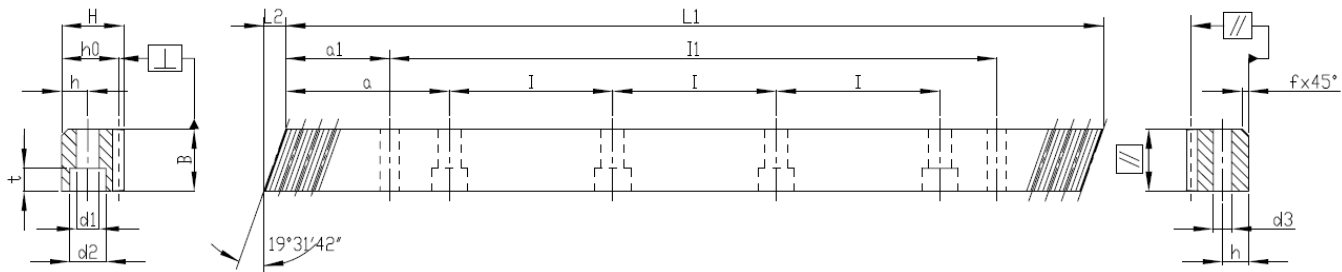

Mn	P _t ⁽¹⁾	L1	L2	Teeth No.	B	H	h ₀	f	a	I	Hole No.	h	d1	d2	t	a1	II	d3	f _p ⁽²⁾	F _p ⁽³⁾	Order Code *
1	3.33334	500	5.3	150	15	15	14	2	62.5	125	4	6	5	8	5	30.3	439.4	5.7	0.008	0.029	016CR050C10
1	3.33334	1000	5.3	300	15	15	14	2	62.5	125	8	6	5	8	5	30.3	939.4	5.7	0.008	0.033	016CRI100C10
1.5	5.00001	500	6.7	100	19	19	17.5	2	62.5	125	4	8	7	11	7	31.7	436.6	5.7	0.008	0.029	1J6CR050C10
1.5	5.00001	1000	6.7	200	19	19	17.5	2	62.5	125	8	8	7	11	7	31.7	936.6	5.7	0.008	0.034	1J6CRI100C10
2	6.66668	500	8.5	75	24	24	22	2	62.5	125	4	8	7	11	7	31.7	436.6	5.7	0.008	0.029	026CR050C10
2	6.66668	1000	8.5	150	24	24	22	2	62.5	125	8	8	7	11	7	31.7	936.6	5.7	0.008	0.034	026CRI100C10
2.5	8.33335	500	10.3	60	29	29	26.5	2	62.5	125	4	9	10	15	9	35	430	7.7	0.008	0.032	2J6CR050C10
2.5	8.33335	1000	10.3	120	29	29	26.5	2	62.5	125	8	9	10	15	9	35	930	7.7	0.009	0.036	2J6CRI100C10
3	10.00002	500	10.3	50	29	29	26	2	62.5	125	4	9	10	15	9	35	430	7.7	0.008	0.032	036CR050C10
3	10.00002	1000	10.3	100	29	29	26	2	62.5	125	8	9	10	15	9	35	930	7.7	0.009	0.037	036CRI100C10
4	13.33335	506.67	13.8	38	39	39	35	3	62.5	125	4	12	10	15	9	33.3	433	7.7	0.009	0.034	046CR050C10
4	13.33335	1000	13.8	75	39	39	35	3	62.5	125	8	12	10	15	9	33.3	933.4	7.7	0.01	0.04	046CRI100C10

(1) Teeth Pitch $P_t = \text{Module} \times \pi / \cos(19^\circ 31' 42'')$ (2) f_p = Single Pitch Error (3) F_p = Total Pitch Error

* For all models APEX also provides Rack without screw-holes. By ordering please change the 2nd last order-code position from "1" to "0". Please also refer to page 14.

Quality 8H / Q&T Alloy Steel
 Material Quenched and Tempered
 Tooth Thickness Tolerance : -48 ~ 0 μm
 Right-Hand Helical Teeth
 Teeth Milled / All Sides Milled

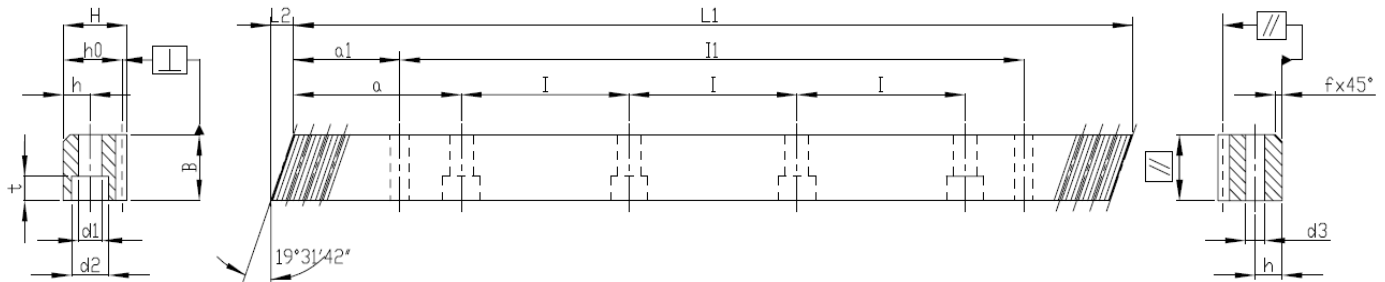

Mn	Pt ⁽¹⁾	L1	L2	Teeth No.	B	H	ho	f	a	I	Hole No.	h	d1	d2	t	a1	I1	d3	fp ⁽²⁾	Fp ⁽³⁾	Order Code *
2	6.66668	500	8.9	75	25	24	22	2	62.5	125	4	8	7	11	7	31.7	436.6	5.7	0.015	0.057	028HR050Q10
2	6.66668	1000	8.9	150	25	24	22	2	62.5	125	8	8	7	11	7	31.7	936.6	5.7	0.016	0.066	028HR100Q10
2	6.66668	1246.67	8.9	187	25	24	22	2	62.5	125	10	8	7	11	7	31.7	1183.3	5.7	0.016	0.066	028HR125Q10
2	6.66668	1500	8.9	225	25	24	22	2	62.5	125	12	8	7	11	7	31.7	1436.6	5.7	0.016	0.066	028HR150Q10
2	6.66668	1746.67	8.9	262	25	24	22	2	62.5	125	14	8	7	11	7	31.7	1683.3	5.7	0.016	0.066	028HR175Q10
2	6.66668	2000	8.9	300	25	24	22	2	62.5	125	16	8	7	11	7	31.7	1936.6	5.7	0.018	0.074	028HR200Q10
3	10.00002	500	10.6	50	30	29	26	2	62.5	125	4	9	10	15	9	35	430	7.7	0.016	0.063	038HR050Q10
3	10.00002	1000	10.6	100	30	29	26	2	62.5	125	8	9	10	15	9	35	930	7.7	0.018	0.072	038HR100Q10
3	10.00002	1250	10.6	125	30	29	26	2	62.5	125	10	9	10	15	9	35	1180	7.7	0.018	0.072	038HR125Q10
3	10.00002	1500	10.6	150	30	29	26	2	62.5	125	12	9	10	15	9	35	1430	7.7	0.018	0.072	038HR150Q10
3	10.00002	1750	10.6	175	30	29	26	2	62.5	125	14	9	10	15	9	35	1680	7.7	0.018	0.072	038HR175Q10
3	10.00002	2000	10.6	200	30	29	26	2	62.5	125	16	9	10	15	9	35	1930	7.7	0.019	0.081	038HR200Q10
4	13.33335	506.67	14.2	38	40	39	35	3	62.5	125	4	12	10	15	9	33.3	433	7.7	0.018	0.068	048HR050Q10
4	13.33335	1000	14.2	75	40	39	35	3	62.5	125	8	12	10	15	9	33.3	933.4	7.7	0.019	0.078	048HR100Q10
4	13.33335	1253.34	14.2	94	40	39	35	3	62.5	125	10	12	10	15	9	33.3	1186.7	7.7	0.019	0.078	048HR125Q10
4	13.33335	1506.67	14.2	113	40	39	35	3	62.5	125	12	12	10	15	9	33.3	1433.4	7.7	0.019	0.078	048HR150Q10
4	13.33335	1760	14.2	132	40	39	35	3	62.5	125	14	12	10	15	9	33.3	1693.4	7.7	0.019	0.078	048HR175Q10
4	13.33335	2000	14.2	150	40	39	35	3	62.5	125	16	12	10	15	9	33.3	1933.4	7.7	0.021	0.088	048HR200Q10

(1) Teeth Pitch Pt = Module x π / cos (19°31'42") (2) fp = Single Pitch Error (3) Fp = Total Pitch Error

* For all models APEX also provides Rack without screw-holes. By ordering please change the 2nd last order-code position from "I" to "0". Please also refer to page 14.

Especially for the application without back-support.

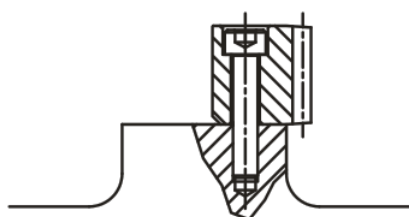

Without alignment / back-support

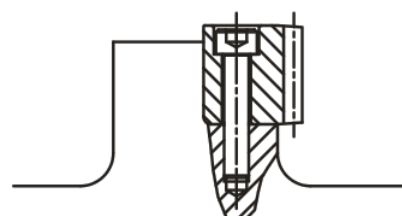

With alignment / back-support

Rack with Helical Teeth

Quality 8 / Carbon Steel
 Tooth Thickness Tolerance : -48 ~ 0 μm
 Right-Hand Helical Teeth
 Material Normalized
 Teeth Milled and all Sides Milled

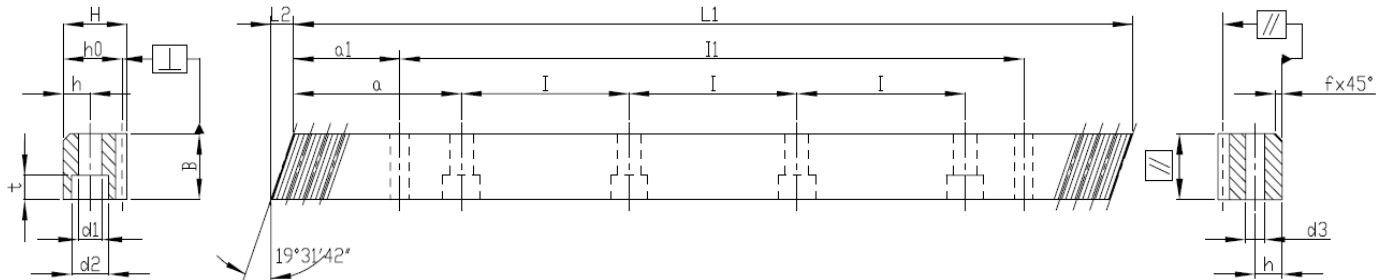

Mn	P _t ⁽¹⁾	L1	L2	Teeth No.	B	H	h ₀	f	a	I	Hole No.	h	d1	d2	t	a1	I1	d3	f _p ⁽²⁾	F _p ⁽³⁾	Order Code *
1.5	5.00001	500	6	100	17	17	15.5	2	62.5	125	4	6	6	10	6	31.7	436.6	5.7	0.015	0.057	1J08R050C10
1.5	5.00001	1000	6	200	17	17	15.5	2	62.5	125	8	6	6	10	6	31.7	936.6	5.7	0.016	0.066	1J08R100C10
1.5	5.00001	1250	6	250	17	17	15.5	2	62.5	125	10	6	6	10	6	31.7	1186.6	5.7	0.016	0.066	1J08R125C10
1.5	5.00001	1500	6	300	17	17	15.5	2	62.5	125	12	6	6	10	6	31.7	1436.6	5.7	0.016	0.066	1J08R150C10
1.5	5.00001	1750	6	350	17	17	15.5	2	62.5	125	14	6	6	10	6	31.7	1686.6	5.7	0.016	0.066	1J08R175C10
1.5	5.00001	2000	6	400	17	17	15.5	2	62.5	125	16	6	6	10	6	31.7	1936.6	5.7	0.018	0.074	1J08R200C10
2	6.66668	500	9.2	75	26	24	22	2	62.5	125	4	8	7	11	7	31.7	436.6	5.7	0.015	0.057	0208R050C10
2	6.66668	1000	9.2	150	26	24	22	2	62.5	125	8	8	7	11	7	31.7	936.6	5.7	0.016	0.066	0208R100C10
2	6.66668	1246.67	9.2	187	26	24	22	2	62.5	125	10	8	7	11	7	31.7	1183.3	5.7	0.016	0.066	0208R125C10
2	6.66668	1500	9.2	225	26	24	22	2	62.5	125	12	8	7	11	7	31.7	1436.6	5.7	0.016	0.066	0208R150C10
2	6.66668	1746.67	9.2	262	26	24	22	2	62.5	125	14	8	7	11	7	31.7	1683.3	5.7	0.016	0.066	0208R175C10
2	6.66668	2000	9.2	300	26	24	22	2	62.5	125	16	8	7	11	7	31.7	1936.6	5.7	0.018	0.074	0208R200C10
2.5	8.33335	500	10.6	60	30	29	26.5	2	62.5	125	4	9	10	15	9	35	430	7.7	0.016	0.062	2J08R050C10
2.5	8.33335	1000	10.6	120	30	29	26.5	2	62.5	125	8	9	10	15	9	35	930	7.7	0.018	0.072	2J08R100C10
2.5	8.33335	1250	10.6	150	30	29	26.5	2	62.5	125	10	9	10	15	9	35	1180	7.7	0.018	0.072	2J08R125C10
2.5	8.33335	1500	10.6	180	30	29	26.5	2	62.5	125	12	9	10	15	9	35	1430	7.7	0.018	0.072	2J08R150C10
2.5	8.33335	1750	10.6	210	30	29	26.5	2	62.5	125	14	9	10	15	9	35	1680	7.7	0.018	0.072	2J08R175C10
2.5	8.33335	2000	10.6	240	30	29	26.5	2	62.5	125	16	9	10	15	9	35	1930	7.7	0.019	0.081	2J08R200C10
3	10.00002	500	11	50	31	29	26	2	62.5	125	4	9	10	15	9	35	430	7.7	0.016	0.063	0308R050C10
3	10.00002	1000	11	100	31	29	26	2	62.5	125	8	9	10	15	9	35	930	7.7	0.018	0.072	0308R100C10
3	10.00002	1250	11	125	31	29	26	2	62.5	125	10	9	10	15	9	35	1180	7.7	0.018	0.072	0308R125C10
3	10.00002	1500	11	150	31	29	26	2	62.5	125	12	9	10	15	9	35	1430	7.7	0.018	0.072	0308R150C10
3	10.00002	1750	11	175	31	29	26	2	62.5	125	14	9	10	15	9	35	1680	7.7	0.018	0.072	0308R175C10
3	10.00002	2000	11	200	31	29	26	2	62.5	125	16	9	10	15	9	35	1930	7.7	0.019	0.081	0308R200C10

(1) Teeth Pitch Pt = Module x π / cos (19°31'42") (2) f_p = Single Pitch Error (3) F_p = Total Pitch Error

* For all models APEX also provides Rack without screw-holes. By ordering please change the 2nd last order-code position from "I" to "O". Please also refer to page I4.

Quality 8 / Carbon Steel
 Tooth Thickness Tolerance : -48 ~ 0 μm
 Right-Hand Helical Teeth
 Material Normalized
 Teeth Milled and all Sides Milled

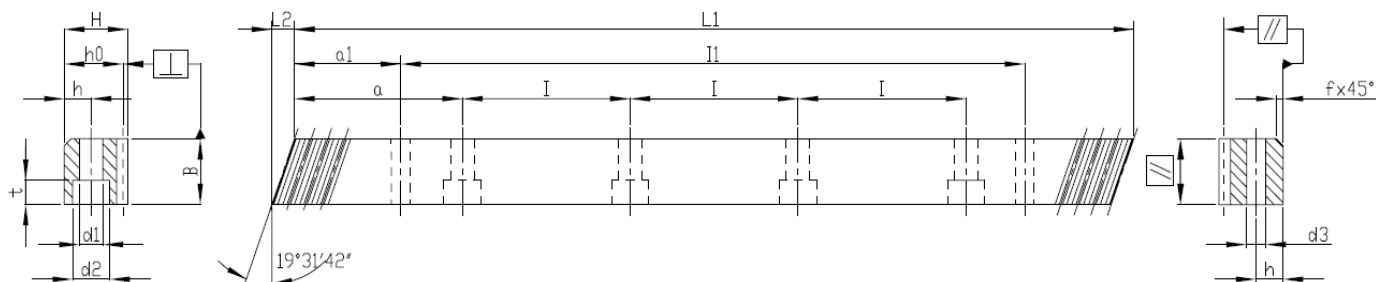

Mn	Pt ⁽¹⁾	L1	L2	Teeth No.	B	H	ho	f	a	I	Hole No.	h	d1	d2	t	a1	l1	d3	fp ⁽²⁾	Fp ⁽³⁾	Order Code*
4	13.33335	506.67	14.5	38	41	39	35	3	62.5	125	4	12	10	15	9	33.3	433	7.7	0.018	0.068	0408R050C10
4	13.33335	1000	14.5	75	41	39	35	3	62.5	125	8	12	10	15	9	33.3	933.4	7.7	0.019	0.078	0408R100C10
4	13.33335	1000	14.5	75	41	39	35	3	62.5	125	8	12	14	20	13	33.3	933.4	11.7	0.019	0.078	0408R100CS0
4	13.33335	1253.34	14.5	94	41	39	35	3	62.5	125	10	12	10	15	9	33.3	1186.7	7.7	0.019	0.078	0408R125C10
4	13.33335	1506.67	14.5	113	41	39	35	3	62.5	125	12	12	10	15	9	33.3	1433.4	7.7	0.019	0.078	0408R150C10
4	13.33335	1506.67	14.5	113	41	39	35	3	62.5	125	12	12	14	20	13	33.3	1433.4	11.7	0.019	0.078	0408R150CS0
4	13.33335	1760	14.5	132	41	39	35	3	62.5	125	14	12	10	15	9	33.3	1693.4	7.7	0.019	0.078	0408R175C10
4	13.33335	2000	14.5	150	41	39	35	3	62.5	125	16	12	10	15	9	33.3	1933.4	7.7	0.021	0.088	0408R200C10
4	13.33335	2000	14.5	150	41	39	35	3	62.5	125	16	12	14	20	13	33.3	1933.4	11.7	0.021	0.088	0408R200CS0
5	16.66669	500	17.7	30	50	39	34	3	62.5	125	4	12	14	20	13	37.5	425	11.7	0.018	0.068	0508R050C10
5	16.66669	1000	17.7	60	50	39	34	3	62.5	125	8	12	14	20	13	37.5	925	11.7	0.019	0.078	0508R100C10
5	16.66669	1250	17.7	75	50	39	34	3	62.5	125	10	12	14	20	13	37.5	1175	11.7	0.019	0.078	0508R125C10
5	16.66669	1500	17.7	90	50	39	34	3	62.5	125	12	12	14	20	13	37.5	1425	11.7	0.019	0.078	0508R150C10
5	16.66669	1750	17.7	105	50	39	34	3	62.5	125	14	12	14	20	13	37.5	1675	11.7	0.019	0.078	0508R175C10
5	16.66669	2000	17.7	120	50	39	34	3	62.5	125	16	12	14	20	13	37.5	1925	11.7	0.021	0.088	0508R200C10
6	20.00003	500	21.3	25	60	49	43	3	62.5	125	4	16	18	26	17	37.5	425	15.7	0.018	0.068	0608R050C10
6	20.00003	1000	21.3	50	60	49	43	3	62.5	125	8	16	18	26	17	37.5	925	15.7	0.019	0.078	0608R100C10
6	20.00003	1260	21.3	63	60	49	43	3	62.5	125	10	16	18	26	17	37.5	1185	15.7	0.019	0.078	0608R125C10
6	20.00003	1500	21.3	75	60	49	43	3	62.5	125	12	16	18	26	17	37.5	1425	15.7	0.019	0.078	0608R150C10
6	20.00003	1760	21.3	88	60	49	43	3	62.5	125	14	16	18	26	17	37.5	1685	15.7	0.019	0.078	0608R175C10
6	20.00003	2000	21.3	100	60	49	43	3	62.5	125	16	16	18	26	17	37.5	1925	15.7	0.021	0.088	0608R200C10
8	26.66671	480	28.7	18	81	79	71	3	60	120	4	25	22	33	21	120	240	19.7	0.021	0.073	0808R050C10
8	26.66671	960	28.7	36	81	79	71	3	60	120	8	25	22	33	21	120	720	19.7	0.022	0.084	0808R100C10
8	26.66671	1200	28.7	45	81	79	71	3	60	120	10	25	22	33	21	120	960	19.7	0.022	0.084	0808R125C10
8	26.66671	1440	28.7	54	81	79	71	3	60	120	12	25	22	33	21	120	1200	19.7	0.022	0.084	0808R150C10
8	26.66671	1680	28.7	63	81	79	71	3	60	120	14	25	22	33	21	120	1440	19.7	0.022	0.084	0808R175C10
8	26.66671	1920	28.7	72	81	79	71	3	60	120	16	25	22	33	21	120	1680	19.7	0.024	0.095	0808R200C10
10	33.33339	1000	35.5	30	100	99	89	3	62.5	125	8	32	33	48	32	125	750	19.7	0.022	0.084	1008R100C10
12	40.00006	1000	42.6	25	120	120	108	3	40	125	8	40	39	58	38	102.5	750	19.7	0.026	0.09	1208R100C10

(1) Teeth Pitch Pt = Module x π / cos (19°31'42") (2) fp = Single Pitch Error (3) Fp = Total Pitch Error

* For all models APEX also provides Rack without screw-holes. By ordering please change the 2nd last order-code position from "I" to "O". Please also refer to page 14.

Rack with Helical Teeth

Quality 10 / Carbon Steel
 Tooth Thickness Tolerance : -90 ~ 0 μm
 Right-Hand Helical Teeth
 Teeth Milled and Induction Hardened
 All Sides Milled

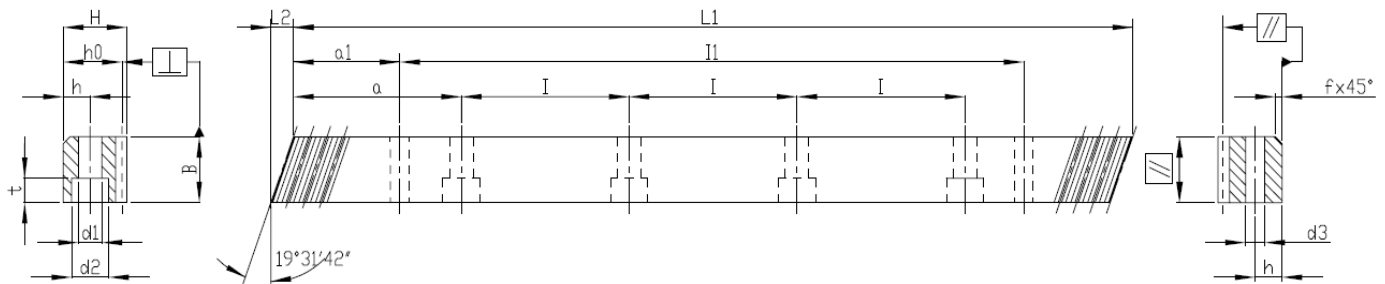

Mn	P _t ⁽¹⁾	L1	L2	Teeth No.	B	H	h ₀	f	a	I	Hole No.	h	d1	d2	t	a1	II	d3	f _p ⁽²⁾	F _p ⁽³⁾	Order Code *
1.5	5.00001	500	6	100	17	17	15.5	2	62.5	125	4	6	6	10	6	31.7	436.6	5.7	0.034	0.128	IJ10R050C10
1.5	5.00001	1000	6	200	17	17	15.5	2	62.5	125	8	6	6	10	6	31.7	936.6	5.7	0.037	0.148	IJ10R100C10
1.5	5.00001	1250	6	250	17	17	15.5	2	62.5	125	10	6	6	10	6	31.7	1186.6	5.7	0.037	0.148	IJ10R125C10
1.5	5.00001	1500	6	300	17	17	15.5	2	62.5	125	12	6	6	10	6	31.7	1436.6	5.7	0.037	0.148	IJ10R150C10
1.5	5.00001	1750	6	350	17	17	15.5	2	62.5	125	14	6	6	10	6	31.7	1686.6	5.7	0.037	0.148	IJ10R175C10
1.5	5.00001	2000	6	400	17	17	15.5	2	62.5	125	16	6	6	10	6	31.7	1936.6	5.7	0.041	0.167	IJ10R200C10
2	6.66668	500	9.2	75	26	24	22	2	62.5	125	4	8	7	11	7	31.7	436.6	5.7	0.034	0.128	0210R050C10
2	6.66668	1000	9.2	150	26	24	22	2	62.5	125	8	8	7	11	7	31.7	936.6	5.7	0.037	0.148	0210R100C10
2	6.66668	1246.67	9.2	187	26	24	22	2	62.5	125	10	8	7	11	7	31.7	1183.3	5.7	0.037	0.148	0210R125C10
2	6.66668	1500	9.2	225	26	24	22	2	62.5	125	12	8	7	11	7	31.7	1436.6	5.7	0.037	0.148	0210R150C10
2	6.66668	1746.67	9.2	262	26	24	22	2	62.5	125	14	8	7	11	7	31.7	1683.3	5.7	0.037	0.148	0210R175C10
2	6.66668	2000	9.2	300	26	24	22	2	62.5	125	16	8	7	11	7	31.7	1936.6	5.7	0.041	0.167	0210R200C10
2.5	8.33335	500	10.6	60	30	29	26.5	2	62.5	125	4	9	10	15	9	35	430	7.7	0.036	0.139	2J10R050C10
2.5	8.33335	1000	10.6	120	30	29	26.5	2	62.5	125	8	9	10	15	9	35	930	7.7	0.039	0.16	2J10R100C10
2.5	8.33335	1250	10.6	150	30	29	26.5	2	62.5	125	10	9	10	15	9	35	1180	7.7	0.039	0.16	2J10R125C10
2.5	8.33335	1500	10.6	180	30	29	26.5	2	62.5	125	12	9	10	15	9	35	1430	7.7	0.039	0.16	2J10R150C10
2.5	8.33335	1750	10.6	210	30	29	26.5	2	62.5	125	14	9	10	15	9	35	1680	7.7	0.039	0.16	2J10R175C10
2.5	8.33335	2000	10.6	240	30	29	26.5	2	62.5	125	16	9	10	15	9	35	1930	7.7	0.043	0.181	2J10R200C10
3	10.00002	500	11	50	31	29	26	2	62.5	125	4	9	10	15	9	35	430	7.7	0.036	0.14	0310R050C10
3	10.00002	1000	11	100	31	29	26	2	62.5	125	8	9	10	15	9	35	930	7.7	0.039	0.162	0310R100C10
3	10.00002	1250	11	125	31	29	26	2	62.5	125	10	9	10	15	9	35	1180	7.7	0.039	0.162	0310R125C10
3	10.00002	1500	11	150	31	29	26	2	62.5	125	12	9	10	15	9	35	1430	7.7	0.039	0.162	0310R150C10
3	10.00002	1750	11	175	31	29	26	2	62.5	125	14	9	10	15	9	35	1680	7.7	0.039	0.162	0310R175C10
3	10.00002	2000	11	200	31	29	26	2	62.5	125	16	9	10	15	9	35	1930	7.7	0.043	0.182	0310R200C10

(1) Teeth Pitch Pt = Module x π / cos (19°31'42") (2) f_p = Single Pitch Error (3) F_p = Total Pitch Error

* For all models APEX also provides Rack without screw-holes. By ordering please change the 2nd last order-code position from "1" to "0". Please also refer to page 14.

Quality 10 / Carbon Steel
 Tooth Thickness Tolerance : -90 ~ 0 μm
 Right-Hand Helical Teeth
 Teeth Milled and Induction Hardened
 All Sides Milled

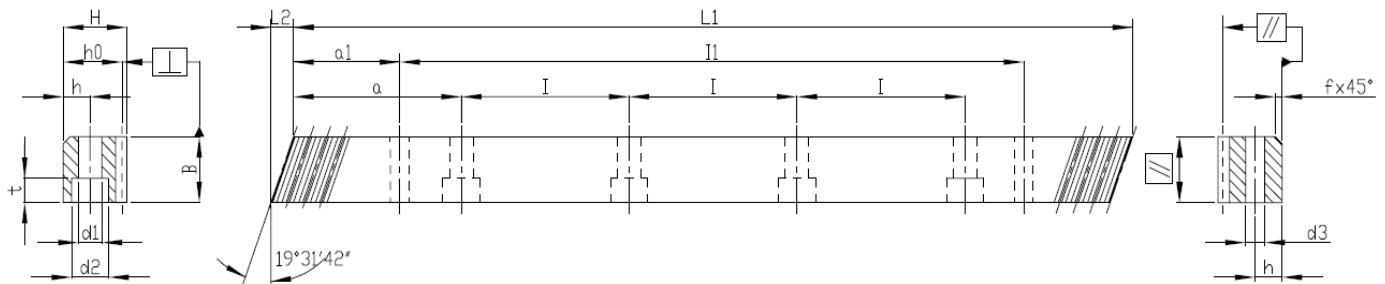

Mn	Pt ⁽¹⁾	L1	L2	Teeth No.	B	H	ho	f	a	I	Hole No.	h	d1	d2	t	a1	II	d3	fp ⁽²⁾	Fp ⁽³⁾	Order Code *
4	13.33335	506.67	14.5	38	41	39	35	3	62.5	125	4	12	10	15	9	33.3	433	7.7	0.04	0.151	0410R050C10
4	13.33335	1000	14.5	75	41	39	35	3	62.5	125	8	12	10	15	9	33.3	933.4	7.7	0.043	0.175	0410R100C10
4	13.33335	1000	14.5	75	41	39	35	3	62.5	125	8	12	14	20	13	33.3	933.4	11.7	0.043	0.175	0410R100CS0
4	13.33335	1253.34	14.5	94	41	39	35	3	62.5	125	10	12	10	15	9	33.3	1186.7	7.7	0.043	0.175	0410R125C10
4	13.33335	1506.67	14.5	113	41	39	35	3	62.5	125	12	12	10	15	9	33.3	1433.4	7.7	0.043	0.175	0410R150C10
4	13.33335	1506.67	14.5	113	41	39	35	3	62.5	125	12	12	14	20	13	33.3	1433.4	11.7	0.043	0.175	0410R150CS0
4	13.33335	1760	14.5	132	41	39	35	3	62.5	125	14	12	10	15	9	33.3	1693.4	7.7	0.043	0.175	0410R175C10
4	13.33335	2000	14.5	150	41	39	35	3	62.5	125	16	12	10	15	9	33.3	1933.4	7.7	0.047	0.197	0410R200C10
4	13.33335	2000	14.5	150	41	39	35	3	62.5	125	16	12	14	20	13	33.3	1933.4	11.7	0.047	0.197	0410R200CS0
5	16.66669	500	17.7	30	50	39	34	3	62.5	125	4	12	14	20	13	37.5	425	11.7	0.04	0.151	0510R050C10
5	16.66669	1000	17.7	60	50	39	34	3	62.5	125	8	12	14	20	13	37.5	925	11.7	0.043	0.175	0510R100C10
5	16.66669	1250	17.7	75	50	39	34	3	62.5	125	10	12	14	20	13	37.5	1175	11.7	0.043	0.175	0510R125C10
5	16.66669	1500	17.7	90	50	39	34	3	62.5	125	12	12	14	20	13	37.5	1425	11.7	0.043	0.175	0510R150C10
5	16.66669	1750	17.7	105	50	39	34	3	62.5	125	14	12	14	20	13	37.5	1675	11.7	0.043	0.175	0510R175C10
5	16.66669	2000	17.7	120	50	39	34	3	62.5	125	16	12	14	20	13	37.5	1925	11.7	0.047	0.197	0510R200C10
6	20.00003	500	21.3	25	60	49	43	3	62.5	125	4	16	18	26	17	37.5	425	15.7	0.04	0.151	0610R050C10
6	20.00003	1000	21.3	50	60	49	43	3	62.5	125	8	16	18	26	17	37.5	925	15.7	0.043	0.175	0610R100C10
6	20.00003	1260	21.3	63	60	49	43	3	62.5	125	10	16	18	26	17	37.5	1185	15.7	0.043	0.175	0610R125C10
6	20.00003	1500	21.3	75	60	49	43	3	62.5	125	12	16	18	26	17	37.5	1425	15.7	0.043	0.175	0610R150C10
6	20.00003	1760	21.3	88	60	49	43	3	62.5	125	14	16	18	26	17	37.5	1685	15.7	0.043	0.175	0610R175C10
6	20.00003	2000	21.3	100	60	49	43	3	62.5	125	16	16	18	26	17	37.5	1925	15.7	0.047	0.197	0610R200C10
8	26.66671	480	28.7	18	81	79	71	3	60	120	4	25	22	33	21	120	240	19.7	0.046	0.163	0810R050C10
8	26.66671	960	28.7	36	81	79	71	3	60	120	8	25	22	33	21	120	720	19.7	0.049	0.188	0810R100C10
8	26.66671	1200	28.7	45	81	79	71	3	60	120	10	25	22	33	21	120	960	19.7	0.049	0.188	0810R125C10
8	26.66671	1440	28.7	54	81	79	71	3	60	120	12	25	22	33	21	120	1200	19.7	0.049	0.188	0810R150C10
8	26.66671	1680	28.7	63	81	79	71	3	60	120	14	25	22	33	21	120	1440	19.7	0.049	0.188	0810R175C10
8	26.66671	1920	28.7	72	81	79	71	3	60	120	16	25	22	33	21	120	1680	19.7	0.053	0.212	0810R200C10
10	33.33339	1000	35.5	30	100	99	89	3	62.5	125	8	32	33	48	32	125	750	19.7	0.049	0.188	1010R100C10
12	40.00006	1000	42.6	25	120	120	108	3	40	125	8	40	39	58	38	102.5	750	19.7	0.059	0.202	1210R100C10

(1) Teeth Pitch Pt = Module x π / cos (19°31'42") (2) fp = Single Pitch Error (3) Fp = Total Pitch Error

* For all models APEX also provides Rack without screw-holes. By ordering please change the 2nd last order-code position from "1" to "0". Please also refer to page 14.

Rack with Helical Teeth

(with Linear-Guide Interface, 90° Type)

Quality 6 / Carbon Steel
 Tooth Thickness Tolerance : -22 ~ 0 μm
 Right-Hand Helical Teeth
 Teeth Induction Hardened and Ground
 All Sides Ground

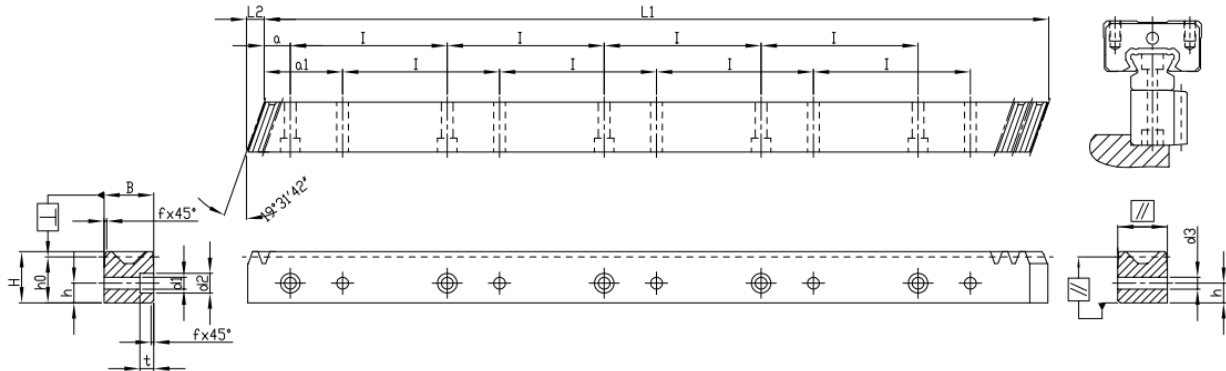

Mn	Pt ⁽¹⁾	L1	L2	Teeth No.	B	H	ho	f	a	l	Hole No.	h	d1	d2	t	a1	d3	fp ⁽²⁾	Fp ⁽³⁾	Order Code
2	6.66668	480	6.7	72	19	19.50	17.50	1	10	60	8	7.5	4.5	7.5	5.3	30	4.5	0.008	0.029	0206R050C10A1
2	6.66668	960	6.7	144	19	19.50	17.50	1	10	60	16	7.5	4.5	7.5	5.3	30	4.5	0.008	0.034	0206R100C10A1
2	6.66668	480	8.5	72	24	24.50	22.50	1	10	60	8	10.0	6.0	9.5	8.5	30	6.0	0.008	0.029	0206R050CS0A1
2	6.66668	960	8.5	144	24	24.50	22.50	1	10	60	16	10.0	6.0	9.5	8.5	30	6.0	0.008	0.034	0206R100CS0A1
3	10.00002	480	10.3	48	29	29.75	26.75	2	10	60	8	11.5	7.0	11.0	9.0	30	7.0	0.008	0.032	0306R050C10A1
3	10.00002	960	10.3	96	29	29.75	26.75	2	10	60	16	11.5	7.0	11.0	9.0	30	7.0	0.009	0.037	0306R100C10A1
4	13.33335	480	13.8	36	39	39.75	35.75	2	20	80	6	14.0	10.0	15.0	9.0	40	10.0	0.009	0.034	0406R050C10A1
4	13.33335	960	13.8	72	39	39.75	35.75	2	20	80	12	14.0	10.0	15.0	9.0	40	10.0	0.010	0.040	0406R100C10A1
4	13.33335	480	13.8	36	39	48.75	44.75	2	20	80	6	17.0	10.0	15.0	9.0	40	10.0	0.009	0.034	0406R050CS0A1
4	13.33335	960	13.8	72	39	48.75	44.75	2	20	80	12	17.0	10.0	15.0	9.0	40	10.0	0.010	0.040	0406R100CS0A1
4	13.33335	840	17.4	63	49	58.00	54.00	2	30	105	8	22.5	14.0	20.0	13.0	60	14.0	0.009	0.034	0406R084CS0A1

Quality 8 / Carbon Steel
 Tooth Thickness Tolerance : -48 ~ 0 μm
 Right-Hand Helical Teeth
 Material Normalized
 Teeth Milled and all Sides Milled

Mn	Pt ⁽¹⁾	L1	L2	Teeth No.	B	H	ho	f	a	l	Hole No.	h	d1	d2	t	a1	d3	fp ⁽²⁾	Fp ⁽³⁾	Order Code
2	6.66668	1920	7.1	288	20	19.50	17.50	1	10	60	32	7.5	4.5	7.5	5.3	30	4.5	0.018	0.074	0208R200C10A1
2	6.66668	1920	8.9	288	25	24.50	22.50	1	10	60	32	10.0	6	9.5	8.5	30	6.0	0.018	0.074	0208R200CS0A1
3	10.00002	1920	10.6	192	30	29.75	26.75	2	10	60	32	11.5	7	11.0	9.0	30	7.0	0.019	0.081	0308R200C10A1
4	13.33335	1920	14.2	144	40	39.75	35.75	2	20	80	24	14.0	10	15.0	9.0	40	10.0	0.021	0.088	0408R200C10A1
4	13.33335	1920	14.5	144	41	48.75	44.75	2	20	80	24	17.0	10	15.0	9.0	40	10.0	0.021	0.088	0408R200CS0A1

(1) Teeth Pitch Pt = Module x π / cos (19°31'42") (2) fp = Single Pitch Error (3) Fp = Total Pitch Error

Rack with Helical Teeth

(with Linear-Guide Interface, 180° Type)

Quality 6 / Carbon Steel
 Tooth Thickness Tolerance : -22 ~ 0 μm
 Right-Hand Helical Teeth
 Teeth Induction Hardened and Ground
 All Sides Ground

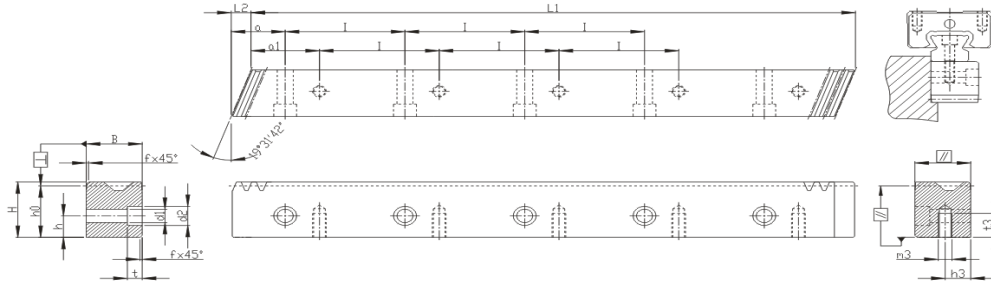

Mn	P _t ⁽¹⁾	L1	L2	Teeth No.	B	H	ho	f	a	l	Hole No.	h	d1	d2	t	a1	m3	h3	t3	f _p ⁽²⁾	F _p ⁽³⁾	Order Code
2	6.66668	960	6.7	144	19	19.50	17.50	1	10	60	16	7.5	6	9.5	6	30	M4	7.5	8.0	0.008	0.034	0206R100C10A2
2	6.66668	960	8.5	144	24	24.50	22.50	1	10	60	16	10.0	7	11.0	7	30	M5	10.0	11.0	0.008	0.034	0206R100CS0A2
3	10.00002	960	10.3	96	29	29.75	26.75	2	10	60	16	11.5	10	15.0	9	30	M6	11.5	13.5	0.009	0.037	0306R100C10A2
4	13.33335	960	13.8	72	39	39.75	35.75	2	20	80	12	14.0	12	18.0	12	40	M8	14.0	16.0	0.010	0.040	0406R100C10A2
4	13.33335	960	13.8	72	39	48.75	44.75	2	20	80	12	17.0	12	18.0	12	40	M8	17.0	16.0	0.010	0.040	0406R100CS0A2
4	13.33335	840	17.4	63	49	58.00	54.00	2	30	105	8	22.5	14	20.0	13	60	M12	22.5	25.0	0.009	0.034	0406R084CS0A2

Quality 8 / Carbon Steel
 Tooth Thickness Tolerance : -48 ~ 0 μm
 Right-Hand Helical Teeth
 Material Normalized
 Teeth Milled and all Sides Milled

Mn	P _t ⁽¹⁾	L1	L2	Teeth No.	B	H	ho	f	a	l	Hole No.	h	d1	d2	t	a1	m3	h3	T3	f _p ⁽²⁾	F _p ⁽³⁾	Order Code
2	6.66668	1920	7.1	288	20	19.50	17.50	1	10	60	32	7.5	6	9.5	6	30	M4	7.5	8.0	0.018	0.074	0208R200C10A2
2	6.66668	1920	8.9	288	25	24.50	22.50	1	10	60	32	10.0	7	11.0	7	30	M5	10.0	11.0	0.018	0.074	0208R200CS0A2
3	10.00002	1920	10.6	192	30	29.75	26.75	2	10	60	32	11.5	10	15.0	9	30	M6	11.5	13.5	0.019	0.081	0308R200C10A2
4	13.33335	1920	14.2	144	40	39.75	35.75	2	20	80	24	14.0	12	18.0	12	40	M8	14.0	16.0	0.021	0.088	0408R200C10A2

(1) Teeth Pitch Pt = Module x π / cos (19°31'42") (2) f_p = Single Pitch Error (3) F_p = Total Pitch Error

APEX High Precision Pinion

APEX Pinion Series

A : Curvic Plate / Page 32

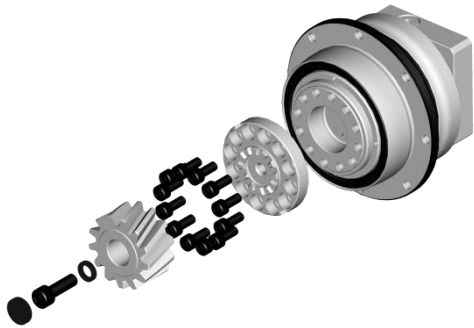

B : Welded Plate / Page 37

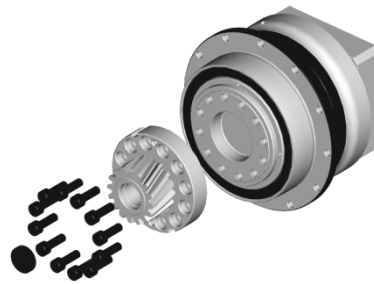

C : Teeth Plate / Page 43

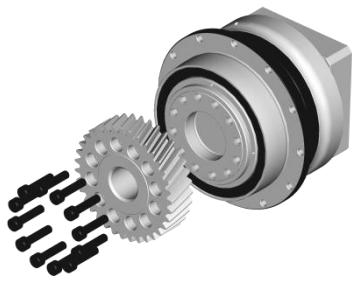

C : Teeth Plate with Flange / Page 44

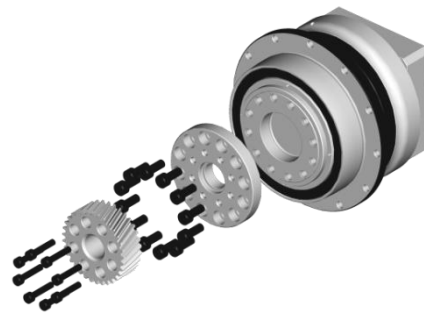

D : DIN 5480 / Page 48

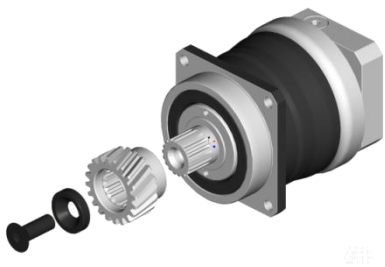

E : Keyway w/o Shrink-Disc / Page 50

F : Keyway w. or w/o Shrink-Disc / Page 52

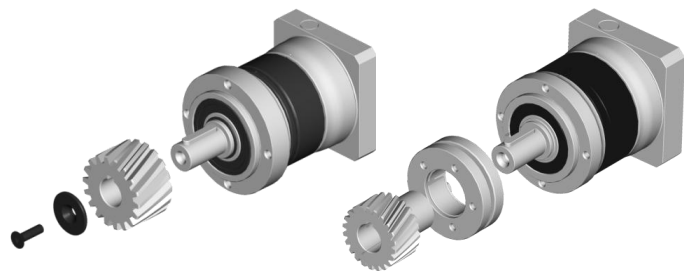

G : Long Shaft w. Keyway / Page 59



H : Long Shaft without Keyway / Page 61



APEX Pinion Curvic Plate

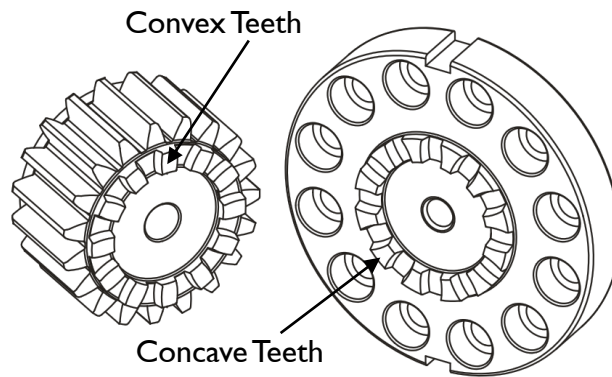

Advantages of Curvic Coupling

- All-Teeth-Coupling between pinion and gearbox
 - Zero backlash
 - Automatic concentricity
 - High torque transmission
- The Round-Out of the gearbox-pinion-set can be adjusted by switching the curvic positions.
- Quick assembly and disassembly or replacement
- More suitable pinion teeth-no. can be chosen, without interference with screwing.

Step 1.

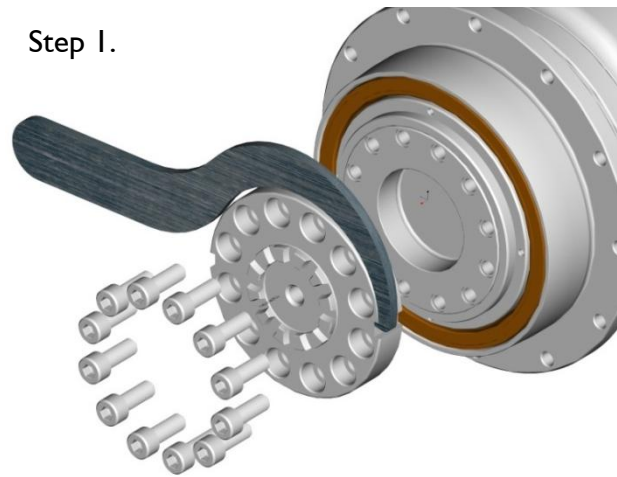

Step 2.

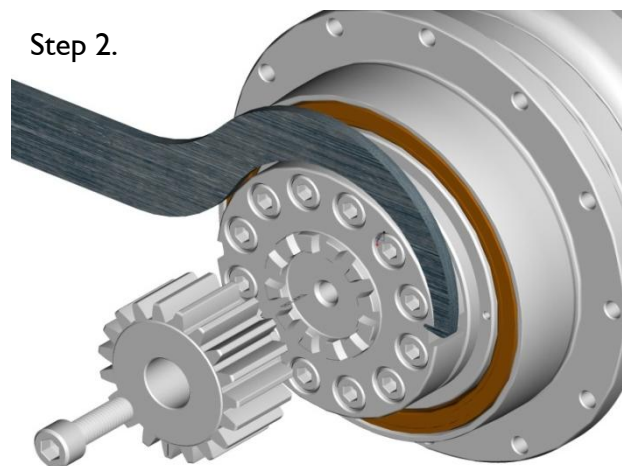

Pinion Order Code

Example : A 02 L 14 B 03I

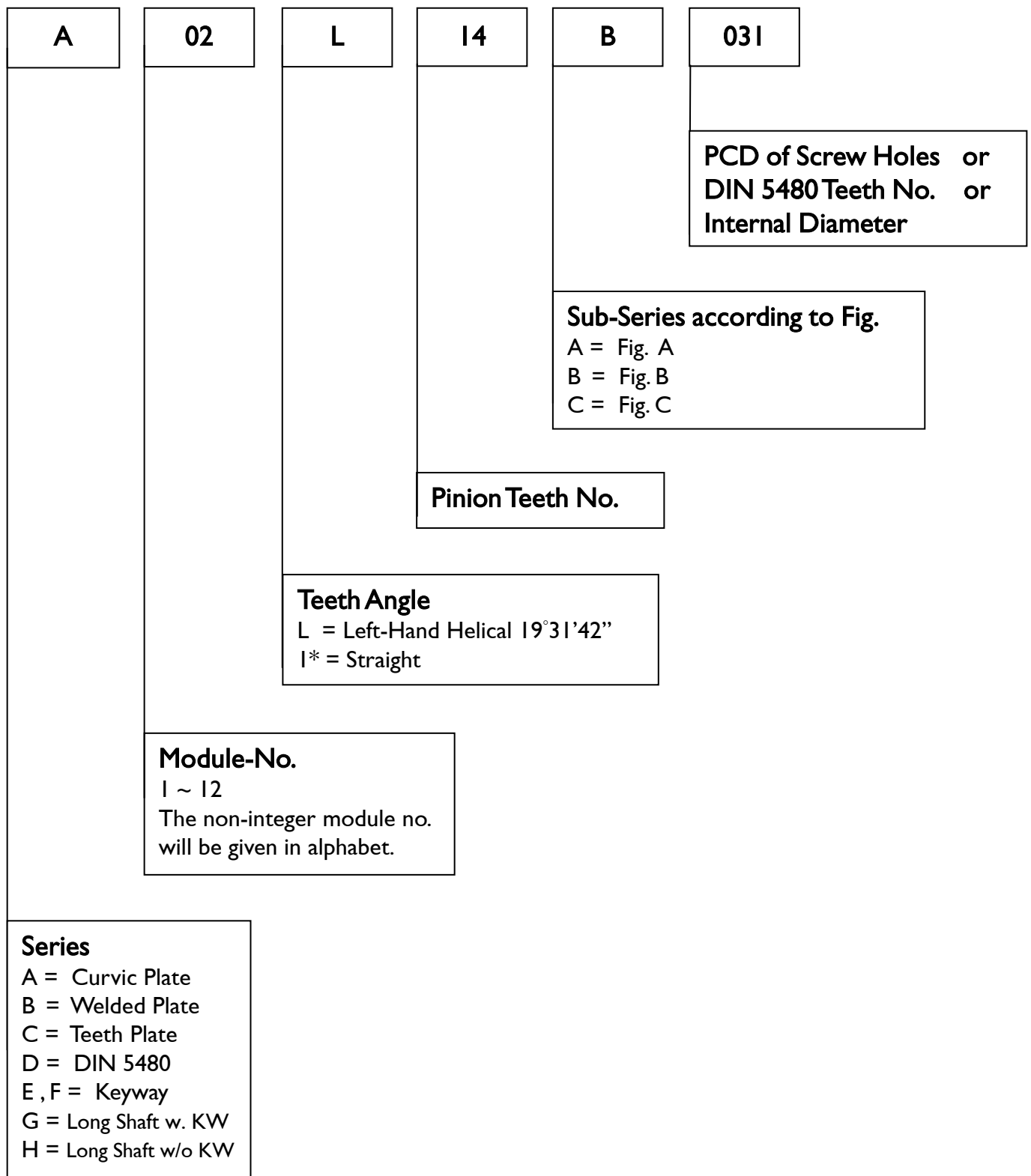

* I = "one"

Pinion with Helical Teeth

(Interface : Curvic Plate / EN ISO 9409-I-A)

Quality DIN 4 / Alloy Steel
 Tooth Thickness Tolerance : e24
 Left-Hand Helical Teeth
 Case-Hardened and Teeth Ground

Bolt Circle Ø31.5

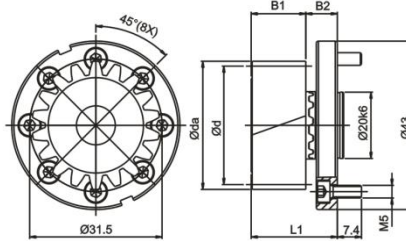

Fig. B

Mn.	z ⁽¹⁾	x ⁽²⁾	da ⁽³⁾	d ⁽⁴⁾	dw ⁽⁵⁾	B1	B2	L1	L ⁽⁶⁾	Fig	Order Code	
											Set	Pinion only
2	17	0.441	41.84	36.075	37.84	26	15	41	113.333	B	A02L17B031	A02L17

Bolt Circle Ø50

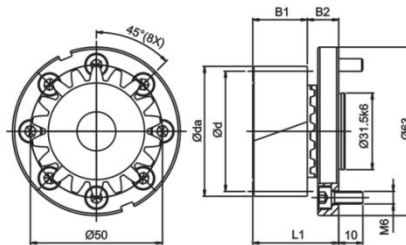

Fig. B

Mn.	z ⁽¹⁾	x ⁽²⁾	da ⁽³⁾	d ⁽⁴⁾	dw ⁽⁵⁾	B1	B2	L1	L ⁽⁶⁾	Fig	Order Code	
											Set	Pinion only
2	20	0.390	48.00	42.441	44.00	26	15	41	133.334	B	A02L20B050	A02L20
3	17	0.441	62.76	54.113	56.76	31	15	46	170.000	B	A03L17B050	A03L17

Bolt Circle Ø63

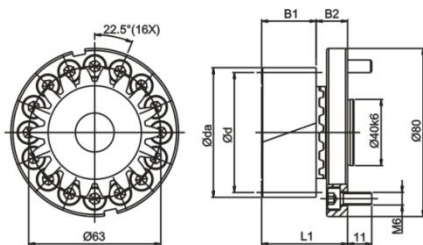

Fig. A

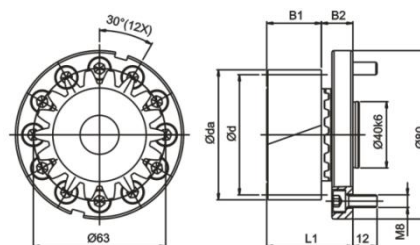

Fig. C

Mn.	z ⁽¹⁾	x ⁽²⁾	da ⁽³⁾	d ⁽⁴⁾	dw ⁽⁵⁾	B1	B2	L1	L ⁽⁶⁾	Fig	Order Code	
											Set	Pinion only
2	20	0.390	48	42.441	44	26	15.0	41.0	133.334	A	A02L20A063	A02L20
							19.5	45.5		C	A02L20C063	
3	20	0.390	72	63.662	66	31	15.0	46.0	200.000	A	A03L20A063	A03L20
							19.5	50.5		C	A03L20C063	

(1) Number of teeth (2) Profile modification factor (3) Diameter of addendum circle (4) Pitch circle diameter
 (5) Working pitch circle diameter (6) Pitch circle length $L = \pi \times d$

Bolt Circle Ø80

Quality DIN 4 / Alloy Steel
Tooth Thickness Tolerance : e24
Left-Hand Helical Teeth
Case-Hardened and Teeth Ground

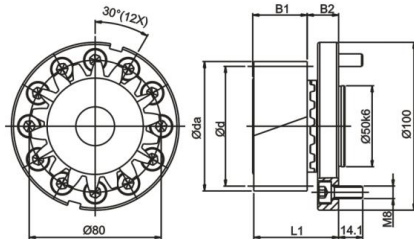

Fig. A

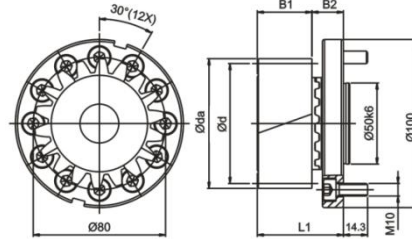

Fig. C

Mn.	z ⁽¹⁾	x ⁽²⁾	da ⁽³⁾	d ⁽⁴⁾	dw ⁽⁵⁾	B1	B2	L1	L ⁽⁶⁾	Fig	Order Code	
											Set	Pinion only
3	18	0.118	64	57.296	58	31	21.5	52.5	180.000	A	A03L18A080	A03L18
										C	A03L18C080	
	20	0.390	72	63.662	66	31	21.5	52.5	200.000	A	A03L20A080	A03L20
										C	A03L20C080	
4	19	0.410	91.92	80.639	83.92	41	21.5	62.5	253.335	A	A04L19A080	A04L19
										C	A04L19C080	

Bolt Circle Ø125

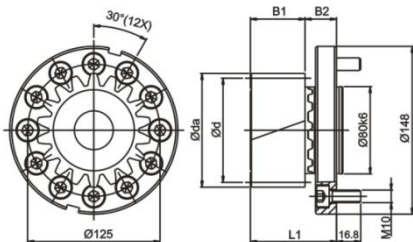

Fig. A

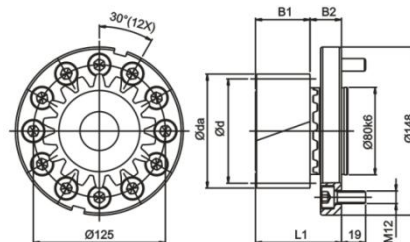

Fig. C

Mn.	z ⁽¹⁾	x ⁽²⁾	da ⁽³⁾	d ⁽⁴⁾	dw ⁽⁵⁾	B1	B2	L1	L ⁽⁶⁾	Fig	Order Code	
											Set	Pinion only
4	18	0.638	89.5	76.394	81.5	41	29	70	240.000	A	A04L18A125	A04L18
										C	A04L18C125	
	20	0.190	94.4	84.883	86.4	41	29	70	266.667	A	A04L20A125	A04L20
										C	A04L20C125	
5	19	0.400	114.8	100.798	104.8	51	29	80	316.666	A	A05L19A125	A05L19
										C	A05L19C125	

Bolt Circle Ø140 / Ø145

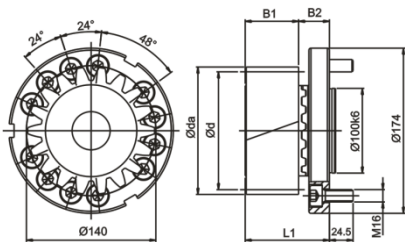

Fig. A

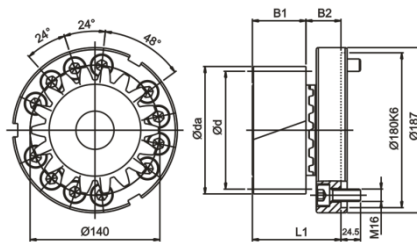

Fig. B

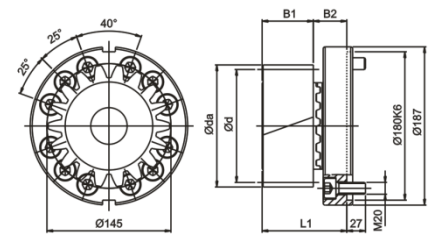

Fig. C

Mn.	z ⁽¹⁾	x ⁽²⁾	da ⁽³⁾	d ⁽⁴⁾	dw ⁽⁵⁾	B1	B2	L1	L ⁽⁶⁾	Fig	Order Code	
											Set	Pinion only
5	18	0.251	108.0	95.493	98.0	51	38	89	300.000	A	A05L18A140	A05L18
										B	A05L18B140	
										C	A05L18C145	
	19	0.400	114.8	100.798	104.8	51	38	89	316.667	A	A05L19A140	A05L19
										B	A05L19B140	
										C	A05L19C145	
6	19	0.404	137.8	120.958	125.8	61	38	99	380.000	A	A06L19A140	A06L19
										B	A06L19B140	
										C	A06L19C145	

Pinion with Helical Teeth

(Interface : Curvic Plate / EN ISO 9409-I-A)

Quality DIN 4 / Alloy Steel
 Tooth Thickness Tolerance : e24
 Left-Hand Helical Teeth
 Case-Hardened and Teeth Ground

Bolt Circle Ø160 / Ø166

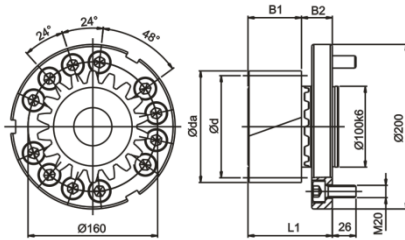

Fig. A

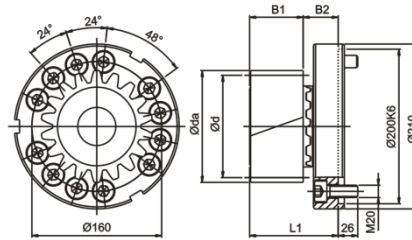

Fig. B

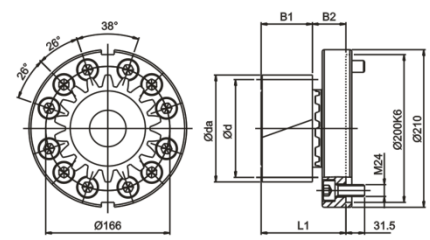
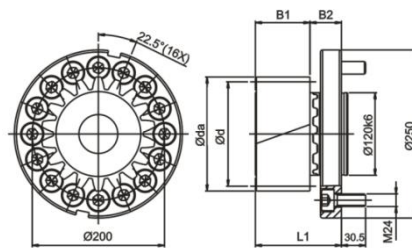

Fig. C

Mn.	z ⁽¹⁾	x ⁽²⁾	da ⁽³⁾	d ⁽⁴⁾	dw ⁽⁵⁾	B1	B2	L1	L ⁽⁶⁾	Fig	Order Code	
											Set	Pinion only
6	18	0.201	129.00	114.592	117.0	61	49	110	360.000	A	A06L18A160	A06L18
										B	A06L18B160	
										C	A06L18C166	
6	19	0.404	137.80	120.958	125.8	61	49	110	380.000	A	A06L19A160	A06L19
										B	A06L19B160	
										C	A06L19C166	
8	19	0.411	183.85	161.277	167.85	81	49	130	506.667	A	A08L19A160	A08L19
										B	A08L19B160	
										C	A08L19C166	

Bolt Circle Ø200



Mn.	z ⁽¹⁾	x ⁽²⁾	da ⁽³⁾	d ⁽⁴⁾	dw ⁽⁵⁾	B1	B2	L1	L ⁽⁶⁾	Order Code	
										Set	Pinion only
8	15	0.355	149.00	127.324	133.00	81	50	131	400.000	A08L15A200	A08L15
	19	0.411	183.85	161.277	167.85	81	50	131	506.667	A08L19A200	A08L19

(1) Number of teeth (2) Profile modification factor (3) Diameter of addendum circle (4) Pitch circle diameter
 (5) Working pitch circle diameter (6) Pitch circle length $L = \pi \times d$

Quality DIN 4 / Alloy Steel
 Tooth Thickness Tolerance : e24
 Left-Hand Helical Teeth
 Case-Hardened and Teeth Ground

Bolt Circle Ø250

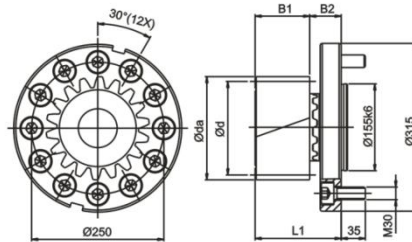

Mn.	z ⁽¹⁾	x ⁽²⁾	da ⁽³⁾	d ⁽⁴⁾	dw ⁽⁵⁾	B1	B2	L1	L ⁽⁶⁾	Order Code	
										Set	Pinion only
10	14	0.523	179.0	148.545	159.0	101	62	163	466.667	A10L14A250	A10L14
	18	0.426	219.5	190.986	199.5	101	62	163	600.000	A10L18A250	A10L18

(1) Number of teeth (2) Profile modification factor (3) Diameter of addendum circle (4) Pitch circle diameter
 (5) Working pitch circle diameter (6) Pitch circle length $L = \pi \times d$

Pinion material carburized, surface hardness reached 60 HRc
 Teeth surface ground to reduce noise and improve wear resistance
 Accessories include hexagon socket head cap screws (Strength 12.9 , DIN 912)

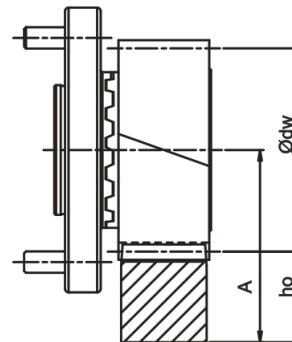
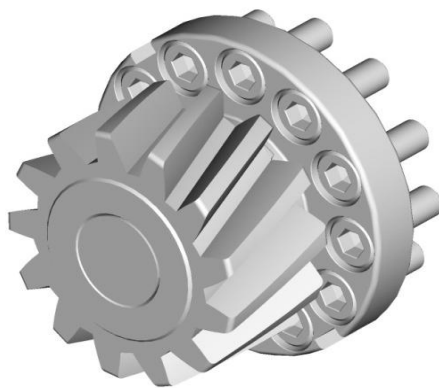

$$A = ho + \frac{\phi dw}{2}$$

In Table 1, the maximum permissible torque of the pinion Curvic Plate and the rack is calculated on the basis of a speed of 1.5 m/s and providing good lubrication (using an automatic lubrication system or manually applied grease every day), the tooth root strength factor $S_F \geq 1.4$, tooth surface strength coefficient $S_H \geq 1$, the safety factor $S_b \cong 1$, and the required service life of 20,000 hours. By higher speed, the max. permissible torque reduced. The user needs to increase the safety factor for the application.
 Backlash changes by different center height. Please contact APEX under WWW.APEXDYNA.COM.

Pinion with Helical Teeth

(Interface : Curvic Plate / EN ISO 9409-I-A)

Table I. The max. permitted torque and feed-force of pinion Curvic Plate

Pinion			Rack		Quality	Q4	Q5H	Q5		Q5 ⁺	Q6	Q6M	Q6C	Q8H	Q8	Q9	Q10	
			Material	Carbon Steel	Alloy Steel		Carbon Steel	Carbon Steel	Carbon Steel	Carbon Steel	Carbon Steel	Carbon Steel	Carbon Steel	Carbon Steel	Q&T Alloy Steel	Carbon Steel	Stainless Steel	Carbon Steel
			Heat Treatment	Induction Hardening	Case Hardening	Carburized Induction	Induction Hardening	Induction Hardening	Induction Hardening	Induction Hardening	Induction Hardening	Normalizing	Quenched Tempered	Normalizing	Solution	Induction Hardening		
Mn	z ⁽¹⁾	dw ⁽⁵⁾	Max. Torque * and Feed-Force															
2	17	37.84	F _{2T} ⁽⁸⁾ (N)		8,870	8,870				8,870	8,870	2,218	3,326	1,940			4,158	
			T _{2B} ⁽⁹⁾ (Nm)		160	160				160	160	40	60	35			75	
	20	44	F _{2T} ⁽⁸⁾ (N)		9,896	9,896				8,247	8,247	1,885	2,356	1,649			4,006	
			T _{2B} ⁽⁹⁾ (Nm)		210	210				175	175	40	50	35			85	
3	17	56.76	F _{2T} ⁽⁸⁾ (N)		18,110	18,110			17,926	17,741	17,741	5,544	8,501	4,435			12,197	
			T _{2B} ⁽⁹⁾ (Nm)		390	390			485	480	480	150	230	120			330	
	18	58	F _{2T} ⁽⁸⁾ (N)		20,420	20,420			19,024	18,850	18,850	6,807	10,472	5,585			14,661	
			T _{2B} ⁽⁹⁾ (Nm)		585	585			545	540	540	195	300	160			420	
	20	66	F _{2T} ⁽⁸⁾ (N)		18,535	18,535			16,022	15,708	15,708	4,555	6,911	3,142			10,838	
			T _{2B} ⁽⁹⁾ (Nm)		590	590			510	500	500	145	220	100			345	
4	18	81.5	F _{2T} ⁽⁸⁾ (N)		30,761		30,761	30,761	30,761	30,761	30,761	12,305	18,719	9,948			21,206	
			T _{2B} ⁽⁹⁾ (Nm)		1,175		1,175	1,175	1,175	1,175	1,175	470	715	380			810	
	19	83.92	F _{2T} ⁽⁸⁾ (N)		32,247		32,247	32,247	32,119	32,119	32,119	14,137	21,950	11,905			22,818	
			T _{2B} ⁽⁹⁾ (Nm)		1,300		1,300	1,300	1,295	1,295	1,295	570	885	480			920	
	20	86.4	F _{2T} ⁽⁸⁾ (N)		34,283		29,452	29,452	29,452	29,452	29,452	10,485	15,669	7,893			21,324	
			T _{2B} ⁽⁹⁾ (Nm)		1,455		1,250	1,250	1,250	1,250	1,250	445	665	335			905	
5	18	98	F _{2T} ⁽⁸⁾ (N)	56,339	56,339		56,339	56,339	56,339	56,339	56,339			20,630			47,438	
			T _{2B} ⁽⁹⁾ (Nm)	2,690	2,690		2,690	2,690	2,690	2,690	2,690				985			2,265
	19	104.8	F _{2T} ⁽⁸⁾ (N)	56,649	56,648		56,649	56,649	56,549	56,549				21,826			47,620	
			T _{2B} ⁽⁹⁾ (Nm)	2,855	2,855		2,855	2,855	2,850	2,850					1,100			2,400
6	18	117	F _{2T} ⁽⁸⁾ (N)	77,580	77,580		77,580	77,580	77,580	77,580	77,580			33,947			67,544	
			T _{2B} ⁽⁹⁾ (Nm)	4,445	4,445		4,445	4,445	4,445	4,445	4,445				1,945			3,870
	19	125.8	F _{2T} ⁽⁸⁾ (N)	73,662	73,662		73,662	73,662	73,662	73,662	73,662			35,136			63,741	
			T _{2B} ⁽⁹⁾ (Nm)	4,455	4,455		4,455	4,455	4,455	4,455	4,455				2,125			3,855
8	15	133	F _{2T} ⁽⁸⁾ (N)	135,717	135,795		135,717		135,638	135,638				40,919			102,966	
			T _{2B} ⁽⁹⁾ (Nm)	8,640	8,645		8,640		8,635	8,635					2,605			6,555
	19	167.85	F _{2T} ⁽⁸⁾ (N)	131,761	131,761		131,761		131,699	131,699				62,315			95,736	
			T _{2B} ⁽⁹⁾ (Nm)	10,625	10,625		10,625		10,620	10,620					5,025			7,720
10	14	159	F _{2T} ⁽⁸⁾ (N)	189,707	189,707		189,707		189,707	189,707				62,877			153,691	
			T _{2B} ⁽⁹⁾ (Nm)	14,090	14,090		14,090		14,090	14,090					4,670			11,415
	18	199.5	F _{2T} ⁽⁸⁾ (N)	204,308	204,308		204,308		204,256	204,256				100,636			166,766	
			T _{2B} ⁽⁹⁾ (Nm)	19,510	19,510		19,510		19,505	19,505					9,610			15,925

* The Maximal Driving Torque is also to be understood as the Maximal Acceleration Torque T_{2B}.

The Emergency Stop Torque T_{2NOT} = 2 x T_{2B}, under the condition limited 1000 times in the whole service period.

(1) Number of Teeth (5) Working Pitch Circle Diameter (in mm) (8) Maximum Feed-Force (9) Maximum Driving Torque

Pinion with Helical Teeth

(Interface : Welded Plate / EN ISO 9409-I-A)

Quality DIN 4 / Alloy Steel
 Tooth Thickness Tolerance : e24
 Left-Hand Helical Teeth
 Case-Hardened and Teeth Ground

Bolt Circle Ø50

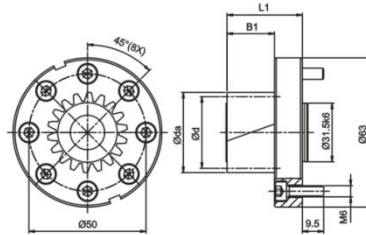

Mn.	z ⁽¹⁾	x ⁽²⁾	da ⁽³⁾	d ⁽⁴⁾	dw ⁽⁵⁾	BI	LI	L ⁽⁶⁾	Order Code
2	12	0.5	31.465	25.465	27.465	26	41	80.000	B02L12A050
	16	0.0	37.953	33.953	33.953	26	41	106.667	B02L16A050

Bolt Circle Ø63

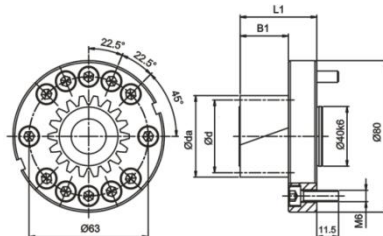

Mn.	z ⁽¹⁾	x ⁽²⁾	da ⁽³⁾	d ⁽⁴⁾	dw ⁽⁵⁾	BI	LI	L ⁽⁶⁾	Order Code
2	12	0.5	31.465	25.465	27.465	26.0	41.0	80.000	B02L12A063
	17	0.0	40.075	36.075	36.075	26.0	41.0	113.333	B02L17A063
	19	0.0	44.319	40.319	40.319	26.0	41.0	126.667	B02L19A063
	23	0.0	52.808	48.808	48.808	26.0	41.0	153.334	B02L23A063
3	12	0.5	47.197	38.197	41.197	32.5	47.5	120.000	B03L12A063
	14	0.3	52.363	44.563	46.363	32.5	47.5	140.000	B03L14A063

Quality DIN 4 / Alloy Steel
 Tooth Thickness Tolerance : e24
 Left-Hand Helical Teeth
 Case-Hardened and Teeth Ground

Bolt Circle Ø80

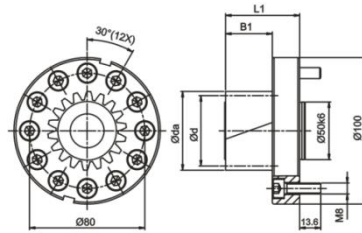

Mn.	z ⁽¹⁾	x ⁽²⁾	da ⁽³⁾	d ⁽⁴⁾	dw ⁽⁵⁾	BI	LI	L ⁽⁶⁾	Order Code
2	12	0.5	31.465	25.465	27.465	26.0	46.0	80.000	B02L12A080
	23	0.0	52.808	48.808	48.808	26.0	46.0	153.334	B02L23A080
	29	0.0	65.540	61.540	61.540	26.0	46.0	193.334	B02L29A080
3	12	0.5	47.197	38.197	41.197	32.5	52.5	120.000	B03L12A080
	16	0.0	56.930	50.930	50.930	32.5	52.5	160.000	B03L16A080
	17	0.0	60.113	54.113	54.113	32.5	52.5	170.000	B03L17A080
	19	0.0	66.479	60.479	60.479	32.5	52.5	190.000	B03L19A080
4	12	0.5	62.930	50.930	54.930	45.0	65.0	160.000	B04L12A080

Bolt Circle Ø125

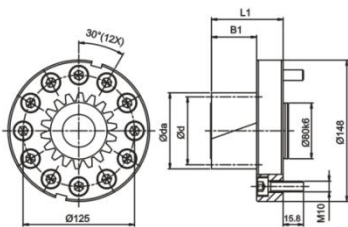

Fig. A

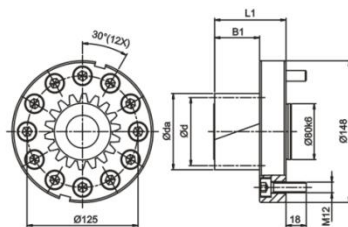

Fig. C

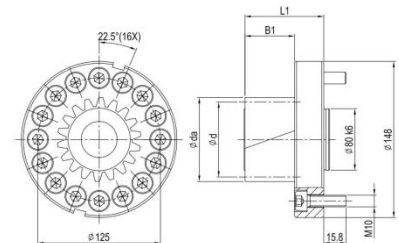

Fig. D

Mn.	z ⁽¹⁾	x ⁽²⁾	da ⁽³⁾	d ⁽⁴⁾	dw ⁽⁵⁾	BI	LI	L ⁽⁶⁾	Fig	Order Code
3	12	0.50	47.197	38.197	41.197	32.5	57.5	120.000	A	B03L12A125
									C	B03L12C125
									D	B03L12D125
	19	0.00	66.479	60.479	60.479	32.5	57.5	190.000	A	B03L19A125
									C	B03L19C125
									D	B03L19D125
	25	0.00	85.578	79.578	79.578	32.5	57.5	250.000	A	B03L25A125
									A	B03L26A125
									C	B03L26C125
26	0.00	88.761	82.761	82.761	32.5	57.5	260.000	D	B03L26D125	
								A	B03L32A125	
								D	B03L32D125	
32	0.00	107.859	101.859	101.859	32.5	57.5	320.000	A	B04L12A125	
								C	B04L12C125	
								D	B04L12D125	
4	12	0.50	62.930	50.930	54.930	45.0	70.0	160.000	A	B04L15A125
									A	B04L16A125
									A	B04L16A125

(1) Number of teeth (2) Profile modification factor (3) Diameter of addendum circle (4) Pitch circle diameter
 (5) Working pitch circle diameter (6) Pitch circle length $L = L = \pi \times d$

Pinion with Helical Teeth

(Interface : Welded Plate / EN ISO 9409-I-A)

Quality DIN 4 / Alloy Steel

Tooth Thickness Tolerance : e24

Left-Hand Helical Teeth

Case-Hardened and Teeth Ground

Bolt Circle $\varnothing 125$

Mn.	z ⁽¹⁾	x ⁽²⁾	da ⁽³⁾	d ⁽⁴⁾	dw ⁽⁵⁾	BI	LI	L ⁽⁶⁾	Fig	Order Code
4	17	0.00	80.150	72.150	72.150	45.0	70.0	226.667	A	B04L17A125
									C	B04L17C125
									D	B04L17D125
	19	0.11	89.519	80.639	81.519	45.0	70.0	253.334	A	B04L19A125
									C	B04L19C125
									D	B04L19D125
	20	0.00	92.883	84.883	84.883	45.0	70.0	266.667	A	B04L20A125
									C	B04L20C125
									D	B04L20D125
23	0.00	105.615	97.615	97.615	45.0	70.0	306.667	A	B04L23A125	
								C	B05L12A125	
								D	B05L12C125	
5	12	0.50	78.662	63.662	68.662	55	80	200.000	A	B05L12A125
									C	B05L12C125
									D	B05L12D125
	16	0.00	94.883	84.883	84.883	55	80	266.667	A	B05L16A125
									C	B05L16C125
									D	B05L16D125
	18	0.00	105.493	95.493	95.493	55	80	300.000	A	B05L18A125
									C	B05L18C125
									D	B05L18D125
6	12	0.50	94.394	76.394	82.394	65	90	240.000	A	B06L12A125
									C	B06L12C125
									D	B06L12D125
	13	0.50	100.761	82.761	88.761	65	90	260.000	A	B06L13A125
									C	B06L15A125
									D	B06L15D125
15	0.00	107.493	95.493	95.493	65	90	300.000	A	B06L15A125	
								C	B06L15C125	
								D	B06L15D125	

Bolt Circle $\varnothing 140$ / $\varnothing 145$

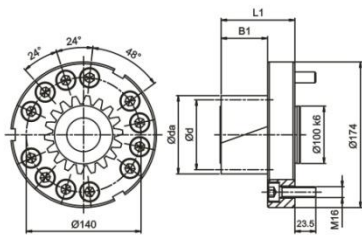

Fig. A

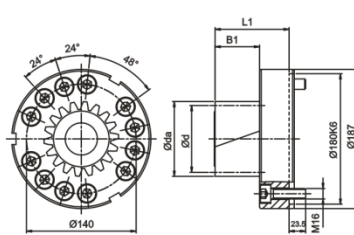

Fig. B

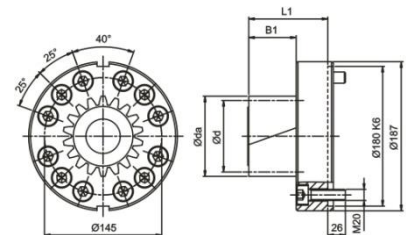

Fig. C

Mn.	z ⁽¹⁾	x ⁽²⁾	da ⁽³⁾	d ⁽⁴⁾	dw ⁽⁵⁾	BI	LI	L ⁽⁶⁾	Fig	Order Code
4	12	0.50	62.930	50.930	54.930	45	79	160.000	A	B04L12A140
									B	B04L12B140
	19	0.11	89.519	80.639	81.519	45	79	253.334	A	B04L19A140
									B	B04L19B140
	20	0.00	92.883	84.883	84.883	45	79	266.667	A	B04L20A140
									B	B04L20B140
C	B04L20C145									
5	14	0.30	87.272	74.272	77.272	55	89	233.334	A	B05L14A140
									B	B05L14B140
	18	0.00	105.493	95.493	95.493	55	89	300.000	A	B05L18A140
									B	B05L18B140
	19	0.00	110.798	100.798	100.798	55	89	316.667	A	B05L19A140
									B	B05L19B140
6	12	0.50	94.394	76.394	82.394	65	99	240.000	A	B06L12A140
									B	B06L12B140
	15	0.00	107.493	95.493	95.493	65	99	300.000	A	B06L15A140
									B	B06L15B140
	16	0.00	113.859	101.859	101.859	65	99	320.000	A	B06L16A140
									B	B06L16B140

Pinion with Helical Teeth

(Interface : Welded Plate / EN ISO 9409-I-A)

Quality DIN 4 / Alloy Steel

Tooth Thickness Tolerance : e24

Left-Hand Helical Teeth

Case-Hardened and Teeth Ground

Bolt Circle Ø160

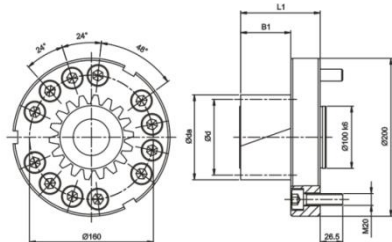

Fig. A

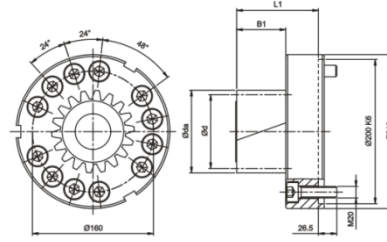

Fig. B

Mn.	z ⁽¹⁾	x ⁽²⁾	da ⁽³⁾	d ⁽⁴⁾	dw ⁽⁵⁾	B1	L1	L ⁽⁶⁾	Fig	Order Code
5	12	0.5	78.662	63.662	68.662	55	100	200.000	A	B05L12A160
									B	B05L12B160
	19	0.0	110.798	100.798	100.798	55	100	316.667	A	B05L19A160
									B	B05L19B160
6	12	0.5	94.394	76.394	82.394	65	110	240.000	A	B06L12A160
									B	B06L12B160
	16	0.0	113.859	101.859	101.859	65	110	320.000	A	B06L16A160
									B	B06L16B160
8	12	0.5	125.859	101.859	109.859	85	130	320.000	A	B08L12A160
									B	B08L12B160

(1) Number of teeth (2) Profile modification factor (3) Diameter of addendum circle (4) Pitch circle diameter
 (5) Working pitch circle diameter (6) Pitch circle length $L = \pi \times d$

Pinion material carburized, surface hardness reached 60 HRc

Teeth surface ground to reduce noise and improve wear resistance

Accessories include hexagon socket head cap screws (Strength 12.9 , DIN 912)

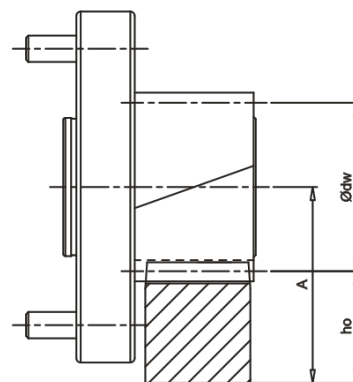

$$A = ho + \frac{\phi dw}{2}$$

In Table 2, the maximum permissible torque of the pinion Welded Plate and the rack is calculated on the basis of a speed of 1.5 m/s and providing good lubrication (using an automatic lubrication system or manually applied grease every day), the tooth root strength factor $S_F \geq 1.4$, tooth surface strength coefficient $S_H \geq 1$, the safety factor $S_B \cong 1$, and the required service life of 20,000 hours. By higher speed, the max. permissible torque reduced. The user needs to increase the safety factor for the application.

Backlash changes by different center height. Please contact APEX under WWW.APEXDYNA.COM.

Note : The strength of screws is limits the max. transmission torque. Please refer to the table below for Pinion Welded Plate.

PCD of Flange	Bolt / Screw Size	Max. Torque (Nm)
Ø50	M6	175
Ø63	M6	335
Ø80	M8	810
Ø125	M10	2,055
	M12	3,060
Ø140	M16	6,620
Ø145	M20	10,885
Ø160	M20	12,000

Table 2. The max. permitted torque and feed-force of pinion Welded Plate

Pinion			Rack												
			Quality	Q4	Q5H	Q5		Q5*	Q6	Q6M	Q6C	Q8H	Q8	Q9	Q10
			Material	Carbon Steel	Alloy Steel		Carbon Steel	Carbon Steel	Carbon Steel	Carbon Steel	Carbon Steel	Carbon Steel	Q&T Alloy Steel	Carbon Steel	Stainless Steel
Heat Treatment	Induction Hardening	Case Hardening	Carburized Induction	Induction Hardening	Induction Hardening	Induction Hardening	Induction Hardening	Induction Hardening	Normalizing	Quenched Tempered	Normalizing	Solution	Induction Hardening		
Mn	z ⁽¹⁾	dw ⁽⁵⁾	Max. Torque * and Feed-Force												
2	12	27.465	F _{2T} ⁽⁸⁾ (N)		6,676	6,676			6,283	6,283	1,178	1,571	1,178	-	2,356
			T _{2B} ⁽⁹⁾ (Nm)		85	85			80	80	15	20	15	-	30
	16	33.953	F _{2T} ⁽⁸⁾ (N)		10,603	10,603			9,425	9,425	2,062	3,240	1,767	-	5,596
			T _{2B} ⁽⁹⁾ (Nm)		180	180			160	160	35	55	30	-	95
	17	36.075	F _{2T} ⁽⁸⁾ (N)		10,811	10,811			9,425	9,425	2,495	3,881	1,663	-	5,544
			T _{2B} ⁽⁹⁾ (Nm)		195	195			170	170	45	70	30	-	100
	19	40.319	F _{2T} ⁽⁸⁾ (N)		11,161	11,161			9,673	9,673	2,976	4,960	2,480	-	5,704
			T _{2B} ⁽⁹⁾ (Nm)		225	225			195	195	60	100	50	-	115
	23	48.808	F _{2T} ⁽⁸⁾ (N)		10,654	10,654			8,810	8,810	2,459	3,893	2,049	-	4,507
			T _{2B} ⁽⁹⁾ (Nm)		260	260			215	215	60	95	50	-	110
	29	61.54	F _{2T} ⁽⁸⁾ (N)		10,725	10,725			8,937	8,937	4,062	6,012	2,925	-	4,225
			T _{2B} ⁽⁹⁾ (Nm)		330	330			275	275	125	185	90	-	130
3	12	41.197	F _{2T} ⁽⁸⁾ (N)		12,828	12,828		12,828	12,566	12,566	2,618	3,927	2,356	-	6,807
			T _{2B} ⁽⁹⁾ (Nm)		245	245		245	240	240	50	75	45	-	130
	14	46.363	F _{2T} ⁽⁸⁾ (N)		16,605	16,605		16,605	16,157	16,157	4,039	6,059	2,917	-	10,771
			T _{2B} ⁽⁹⁾ (Nm)		370	370		370	360	360	90	135	65	-	240
	16	50.93	F _{2T} ⁽⁸⁾ (N)		19,439	19,439		18,850	18,850	18,850	5,694	8,836	4,516	-	13,941
			T _{2B} ⁽⁹⁾ (Nm)		495	495		480	480	480	145	225	115	-	355
	17	54.113	F _{2T} ⁽⁸⁾ (N)		19,774	19,774		19,034	19,034	19,034	6,283	9,794	5,174	-	14,045
			T _{2B} ⁽⁹⁾ (Nm)		535	535		515	515	515	170	265	140	-	380
	19	60.479	F _{2T} ⁽⁸⁾ (N)		20,338	20,338		19,511	19,346	19,346	7,771	11,905	6,449	-	14,551
			T _{2B} ⁽⁹⁾ (Nm)		615	615		590	585	585	235	360	195	-	440
	25	79.578	F _{2T} ⁽⁸⁾ (N)		19,729	19,729		16,965	16,713	16,713	7,665	11,687	6,283	-	11,561
			T _{2B} ⁽⁹⁾ (Nm)		785	785		675	665	665	305	465	250	-	460
	26	82.761	F _{2T} ⁽⁸⁾ (N)		19,695	19,695		16,916	16,675	16,675	8,096	12,445	6,766	-	11,600
			T _{2B} ⁽⁹⁾ (Nm)		815	815		700	690	690	335	515	280	-	480
	32	101.859	F _{2T} ⁽⁸⁾ (N)		19,831	19,831		17,082	16,788	16,788	10,210	12,468	9,327	-	11,290
			T _{2B} ⁽⁹⁾ (Nm)		1,010	1,010		870	855	855	520	635	475	-	575

* The Maximal Driving Torque is also to be understood as the Maximal Acceleration Torque T_{2B}.

The Emergency Stop Torque T_{2NOT} = 2 x T_{2B}, under the condition limited 1000 times in the whole service period.

(1) Number of Teeth (5) Working Pitch Circle Diameter (in mm) (8) Maximum Feed-Force (9) Maximum Driving Torque

Pinion with Helical Teeth

(Interface : Welded Plate / EN ISO 9409-I-A)

Table 2. The max. permitted torque and feed-force of pinion Welded Plate

Pinion			Rack		Quality	Q4	Q5H	Q5		Q5 ⁺	Q6	Q6M	Q6C	Q8H	Q8	Q9	Q10	
			Material		Carbon Steel	Alloy Steel		Carbon Steel	Carbon Steel	Carbon Steel	Carbon Steel	Carbon Steel	Carbon Steel	Carbon Steel	Q&T Alloy Steel	Carbon Steel	Stainless Steel	Carbon Steel
			Heat Treatment		Induction Hardening	Case Hardening	Carburized Induction	Induction Hardening	Induction Hardening	Induction Hardening	Induction Hardening	Induction Hardening	Normalizing	Quenched Tempered	Normalizing	Solution	Induction Hardening	
Mn	z ⁽¹⁾	dw ⁽⁵⁾	Max. Torque * and Feed-Force															
4	12	54.93	F _{2T} ⁽⁸⁾ (N)		22,187		22,187	22,187	21,991	21,991	6,087	9,032	3,927		12,174			
			T _{2B} ⁽⁹⁾ (Nm)		565		565	565	560	560	155	230	100		310			
	15	63.662	F _{2T} ⁽⁸⁾ (N)		33,772		33,772	33,772	33,772	33,772	10,838	16,336	8,482		25,290			
			T _{2B} ⁽⁹⁾ (Nm)		1,075		1,075	1,075	1,075	1,075	345	520	270		805			
	16	67.906	F _{2T} ⁽⁸⁾ (N)		33,870		33,870	33,870	33,870	33,870	12,075	18,260	9,719		25,182			
			T _{2B} ⁽⁹⁾ (Nm)		1,150		1,150	1,150	1,150	1,150	410	620	330		855			
	17	72.15	F _{2T} ⁽⁸⁾ (N)		36,729		35,897	35,897	35,897	35,897	13,167	20,236	10,949		28,551			
			T _{2B} ⁽⁹⁾ (Nm)		1,325		1,295	1,295	1,295	1,295	475	730	395		1,030			
	19	81.519	F _{2T} ⁽⁸⁾ (N)		36,707		36,211	36,211	36,211	36,211	15,129	23,686	13,145		27,778			
			T _{2B} ⁽⁹⁾ (Nm)		1,480		1,460	1,460	1,460	1,460	610	955	530		1,120			
	20	84.883	F _{2T} ⁽⁸⁾ (N)		35,107		30,159	30,159	30,159	30,159	10,956	16,493	8,364		22,148			
			T _{2B} ⁽⁹⁾ (Nm)		1,490		1,280	1,280	1,280	1,280	465	700	355		940			
	23	97.615	F _{2T} ⁽⁸⁾ (N)		35,240		30,323	30,323	30,323	30,323	13,727	21,001	11,269		22,025			
			T _{2B} ⁽⁹⁾ (Nm)		1,720		1,480	1,480	1,480	1,480	670	1,025	550		1,075			
5	12	68.662	F _{2T} ⁽⁸⁾ (N)	31,259	31,259		31,259	31,259	30,945	30,945			8,482		19,007			
			T _{2B} ⁽⁹⁾ (Nm)	995	995		995	995	985	985			270		605			
	14	77.272	F _{2T} ⁽⁸⁾ (N)	42,142	42,142		42,142	42,142	42,142	42,142			12,656		30,967			
			T _{2B} ⁽⁹⁾ (Nm)	1,565	1,565		1,565	1,565	1,565	1,565			470		1,150			
	16	84.883	F _{2T} ⁽⁸⁾ (N)	47,713	47,713		47,713	47,713	47,595	47,595			18,025		36,992			
			T _{2B} ⁽⁹⁾ (Nm)	2,025	2,025		2,025	2,025	2,020	2,020			765		1,570			
	18	95.493	F _{2T} ⁽⁸⁾ (N)	55,187	55,187		55,187	55,187	55,083	55,083			22,096		46,181			
			T _{2B} ⁽⁹⁾ (Nm)	2,635	2,635		2,635	2,635	2,630	2,630			1,055		2,205			
	19	100.798	F _{2T} ⁽⁸⁾ (N)	55,854	55,854		55,854	55,854	55,755	55,755			24,207		46,727			
			T _{2B} ⁽⁹⁾ (Nm)	2,815	2,815		2,815	2,815	2,810	2,810			1,220		2,355			
6	12	82.394	F _{2T} ⁽⁸⁾ (N)	41,233	41,233		41,233	41,233	41,102	41,102			14,792		26,965			
			T _{2B} ⁽⁹⁾ (Nm)	1,575	1,575		1,575	1,575	1,570	1,570			565		1,030			
	13	88.761	F _{2T} ⁽⁸⁾ (N)	45,311	45,311		45,311	45,311	45,191	45,191			17,400		31,295			
			T _{2B} ⁽⁹⁾ (Nm)	1,875	1,875		1,875	1,875	1,870	1,870			720		1,295			
	15	95.493	F _{2T} ⁽⁸⁾ (N)	57,701	57,701		57,701	57,701	57,596	57,596			26,285		44,611			
			T _{2B} ⁽⁹⁾ (Nm)	2,755	2,755		2,755	2,755	2,750	2,750			1,255		2,130			
	16	101.859	F _{2T} ⁽⁸⁾ (N)	62,832	62,832		62,832	62,832	62,832	62,832			29,452		50,854			
			T _{2B} ⁽⁹⁾ (Nm)	3,200	3,200		3,200	3,200	3,200	3,200			1,500		2,590			
	8	12	109.859	F _{2T} ⁽⁸⁾ (N)	63,814	63,814		63,814		63,715	63,715			31,710		41,921		
				T _{2B} ⁽⁹⁾ (Nm)	3,250	3,250		3,250		3,245	3,245			1,615		2,135		

* The Maximal Driving Torque is also to be understood as the Maximal Acceleration Torque T_{2B}.

The Emergency Stop Torque T_{2NOT} = 2 x T_{2B}, under the condition limited 1000 times in the whole service period.

(1) Number of Teeth (5) Working Pitch Circle Diameter (in mm) (8) Maximum Feed-Force (9) Maximum Driving Torque

Pinion with Helical Teeth

(Interface : Teeth Plate / EN ISO 9409-1-A)

Quality DIN 4 / Alloy Steel
 Tooth Thickness Tolerance : e24
 Left-Hand Helical Teeth
 Case-Hardened and Teeth Ground

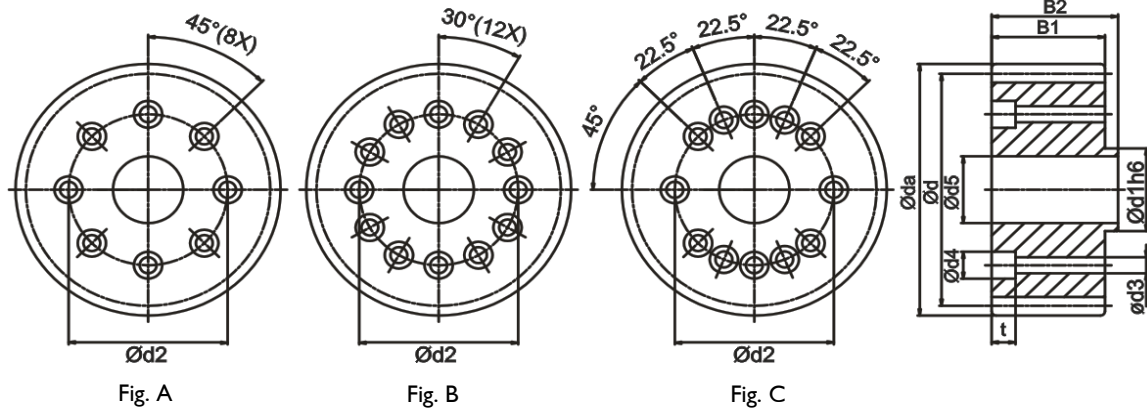

Mn	z ⁽¹⁾	x ⁽²⁾	da ⁽³⁾	d ⁽⁴⁾	dw ⁽⁵⁾	d1	d2	B1	B2	d3	d4	t	d5	L ⁽⁶⁾	Fig	Order Code
2	26	0.407	60.800	55.174	56.800	20.0	31.5	26	29	5.5	9.5	12.0	16.2	173.334	A	C02L26A031
	27	0.000	61.296	57.296	57.296	20.0	31.5	30	33	5.5	9.5	11.0	16.2	180.000	A	C02L27A031
	29	0.415	67.200	61.540	63.200	20.0	31.5	26	29	5.5	9.5	12.0	16.2	193.334	A	C02L29A031
	35	0.382	79.800	74.272	75.800	20.0	31.5	26	29	5.5	9.5	12.0	16.2	233.334	A	C02L35A031
	29	0.415	67.200	61.540	63.200	25.0	40.0	26	29	6.6	11.0	10.5	20.3	193.334	A	C02L29A040
	33	0.393	75.599	70.028	71.599	31.5	50.0	26	29	6.6	11.0	14.0	23.7	220.000	A	C02L33A050
	36	0.000	80.394	76.394	76.394	31.5	50.0	30	33	6.6	11.0	8.0	23.7	240.000	A	C02L36A050
	37	0.421	84.200	78.517	80.200	31.5	50.0	26	29	6.6	11.0	14.0	23.7	246.667	A	C02L37A050
	37	0.421	84.200	78.517	80.200	31.5	50.0	26	29	6.6	11.0	14.0	23.7	246.667	B	C02L37B050
	40	0.379	90.400	84.883	86.400	40.0	63.0	26	29	6.6	11.0	11.5	32.2	266.667	C	C02L40C063
	45	0.327	100.800	95.493	96.800	40.0	63.0	26	29	6.6	11.0	11.5	32.2	300.000	C	C02L45C063
3	30	0.000	101.493	95.493	95.493	40.0	63.0	35	39	6.6	11.0	9.5	32.2	300.000	C	C03L30C063
	31	0.354	106.800	98.676	100.800	31.5	50.0	31	35	6.6	11.0	9.0	23.7	310.000	A	C03L31A050
	35	0.365	119.600	111.409	113.600	50.0	80.0	31	35	9.0	14.0	10.5	32.2	350.000	B	C03L35B080
	40	0.379	135.599	127.324	129.599	50.0	80.0	31	35	9.0	14.0	10.5	32.2	400.000	B	C03L40B080
4	30	0.000	135.324	127.324	127.324	50.0	80.0	45	49	9.0	14.0	9.5	32.2	400.000	B	C04L30B080
	38	0.240	171.200	161.277	163.200	80.0	125.0	41	45	11.0	17.5	10.5	56.1	506.667	B	C04L38B125
5	21	0.000	121.409	111.409	111.409	50.0	80.0	59	64	9.0	14.0	11.5	32.2	350.000	B	C05L21B080
	36	0.000	200.986	190.986	190.986	80.0	125.0	55	60	11.0	17.5	12.5	56.1	600.000	B	C05L36B125

(1) Number of teeth (2) Profile modification factor (3) Diameter of addendum circle (4) Pitch circle diameter
 (5) Working pitch circle diameter (6) Pitch circle length $L = \pi \times d$

The surface hardness reaches to 60 HRC after case hardening
 Teeth surface ground in order to reduce noise and improve wear resistance
 Accessories include hexagon socket head cap screws (Strength 12.9 · DIN 912)

Note : The strength of screws is limits the max. transmission torque. Please refer to the table below for Pinion Teeth Plate.

d1 _{h6}	d2	Bolt / Screw Size	Max. Torque (Nm)
20	31.5	M5	75
25	40	M6	140
31.5	50	M6	175
40	63	M6	335
50	80	M8	810
80	125	M10	2,055

Pinion with Helical Teeth

(Interface : Teeth Plate / EN ISO 9409-1-A)

Quality DIN 4 / Alloy Steel
 Tooth Thickness Tolerance : e24
 Left-Hand Helical Teeth
 Case-Hardened and Teeth Ground

Bolt Circle Ø50

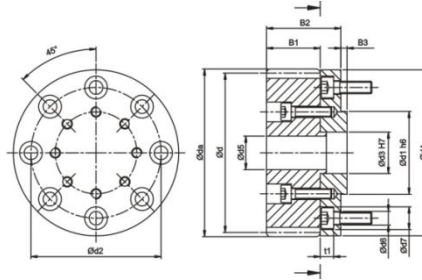

Mn.	z ⁽¹⁾	x ⁽²⁾	da ⁽³⁾	d ⁽⁴⁾	dw ⁽⁵⁾	d1 h ₆	d2	d3 H ₇	d4	d5	B1	B2	B3	d6	d7	t1	L ⁽⁶⁾	Order Code	
																		Pinion	Flange
2	26	0.407	60.800	55.174	56.800	31.5	50	20	63	16.2	26	36	3	6.6	11	6.5	173.334	C02L26A031	FA050
	27	0.000	61.296	57.296	57.296	31.5	50	20	63	16.2	30	40	3	6.6	11	6.5	180.000	C02L27A031	FA050
	29	0.415	67.200	61.540	63.200	31.5	50	20	63	16.2	26	36	3	6.6	11	6.5	193.334	C02L29A031	FA050
	29	0.415	67.200	61.540	63.200	31.5	50	25	63	16.2	26	36	3	6.6	11	6.5	193.334	C02L29A040	FB050
	35	0.382	79.800	74.272	75.800	31.5	50	20	63	16.2	26	36	3	6.6	11	6.5	233.334	C02L35A031	FA050

Bolt Circle Ø63

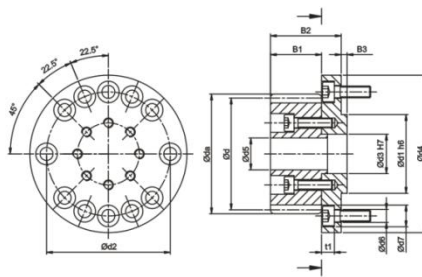

Mn.	z ⁽¹⁾	x ⁽²⁾	da ⁽³⁾	d ⁽⁴⁾	dw ⁽⁵⁾	d1 h ₆	d2	d3 H ₇	d4	d5	B1	B2	B3	d6	d7	t1	L ⁽⁶⁾	Order Code	
																		Pinion	Flange
2	26	0.407	60.800	55.174	56.800	40	63	20	80	16.2	26	36	3	6.6	11	6.5	173.334	C02L26A031	FA063
	27	0.000	61.296	57.296	57.296	40	63	20	80	16.2	30	40	3	6.6	11	6.5	180.000	C02L27A031	FA063
	29	0.415	67.200	61.540	63.200	40	63	20	80	16.2	26	36	3	6.6	11	6.5	193.334	C02L29A031	FA063
	35	0.382	79.800	74.272	75.800	40	63	20	80	16.2	26	36	3	6.6	11	6.5	233.334	C02L35A031	FA063

Bolt Circle Ø80

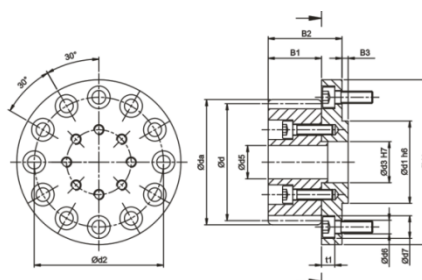

Mn.	z ⁽¹⁾	x ⁽²⁾	da ⁽³⁾	d ⁽⁴⁾	dw ⁽⁵⁾	d1 h ₆	d2	d3 H ₇	d4	d5	B1	B2	B3	d6	d7	t1	L ⁽⁶⁾	Order Code	
																		Pinion	Flange
2	33	0.393	75.599	70.028	71.599	50	80	31.5	100	23.7	26	39	4	9	14	8.6	220.000	C02L33A050	FA080
	36	0.000	80.394	76.394	76.394	50	80	31.5	100	23.7	30	43	4	9	14	8.6	240.000	C02L36A050	FA080
	37	0.421	84.200	78.517	80.200	50	80	31.5	100	23.7	26	39	4	9	14	8.6	246.667	C02L37A050	FA080
3	31	0.354	106.800	98.676	100.800	50	80	31.5	100	23.7	31	44	4	9	14	8.6	310.000	C03L31A050	FA080

Quality DIN 4 / Alloy Steel
 Tooth Thickness Tolerance : e24
 Left-Hand Helical Teeth
 Case-Hardened and Teeth Ground

Bolt Circle Ø125

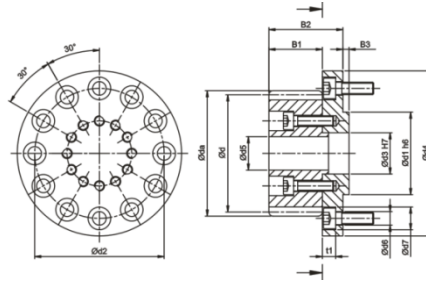

Mn.	z ⁽¹⁾	x ⁽²⁾	da ⁽³⁾	d ⁽⁴⁾	dw ⁽⁵⁾	d1 _{h6}	d2	d3 _{H7}	d4	d5	B1	B2	B3	d6	d7	t1	L ⁽⁶⁾	Order Code	
																		Pinion	Flange
3	35	0.365	119.600	111.409	113.600	80	125	50	148	32.2	31	50	6	11	17.5	14	350	C03L35B080	FA125
	40	0.379	135.599	127.324	125.999	80	125	50	148	32.2	31	50	6	11	17.5	14	400	C03L40B080	FA125
4	30	0.000	135.324	127.324	127.324	80	125	50	148	32.2	45	64	6	11	17.5	14	400	C04L30B080	FA125
5	21	0.000	121.409	111.409	111.409	80	125	50	148	32.2	59	78	6	11	17.5	14	350	C05L21B080	FA125

(1) Number of teeth (2) Profile modification factor (3) Diameter of addendum circle (4) Pitch circle diameter
 (5) Working pitch circle diameter (6) Pitch circle length $L = \pi \times d$

The surface hardness reaches to 60 HRC after case hardening

Teeth surface ground in order to reduce noise and improve wear resistance

Accessories include hexagon socket head cap screws (Strength 12.9 , DIN 912)

Flange material is generally carbon steel, no heat treatment

When pinion combined with flange, the maximum allowable feed force should be checked according to bolt strength

Note : The strength of screws is limits the max. transmission torque. Please refer to the table below for Pinion Teeth Plate with Flange.

d1 _{h6}	d2	Bolt / Screw Size	Max. Torque (Nm)
31.5	50	M6	175
40	63	M6	335
50	80	M8	810
80	125	M10	2,055

Pinion with Helical Teeth

(Interface : Teeth Plate / EN ISO 9409-1-A)

Friction Foil

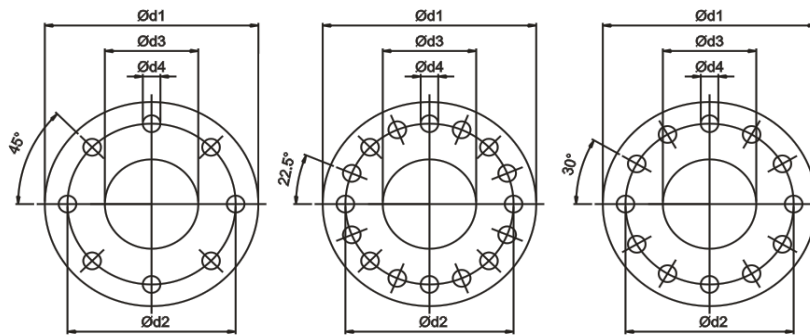

Fig. A

Fig. B

Fig. C

ISO interface	d1	d2	d3	d4	Fig	Max. Torque (Nm)	Order code
A-31.5	39	31.5	20	5.5	A	98	FR031
A-50	62	50	31.5	6.6	A	228	FR050
A-63	80	63	40	6.6	B	435	FR063
A-80	100	80	50	9	C	1050	FR080
A-125	148	125	80	11	C	2670	FR125

To apply the diamond-coated friction foil between the teeth plate and the extending flange, the static friction coefficient is increased. Hence the effective transmission torque can be enhanced at about 30%. Please also refer to the torque limitation due to screws, Page.42.

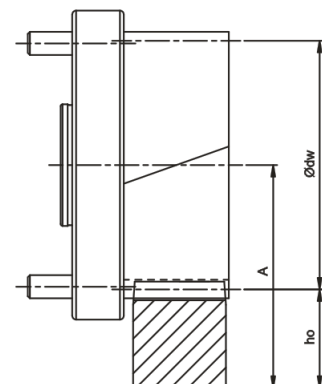
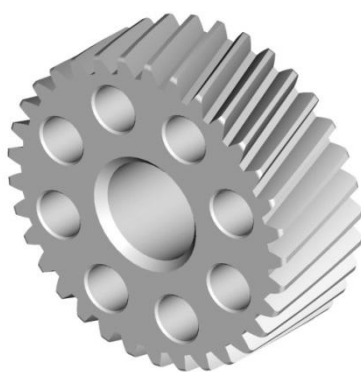

$$A = h_o + \frac{\phi dw}{2}$$

In Table 3, the maximum permissible torque of pinion Teeth Plate, and the rack is calculated on the basis of a speed of 1.5 m/s and providing good lubrication (using an automatic lubrication system or manually applied grease every day), the tooth root strength factor $S_F \geq 1.4$, tooth surface strength coefficient $S_H \geq 1$, the safety factor $S_B \cong 1$, and the required service life of 20,000 hours. By higher speed, the max. permissible torque reduced. The user needs to increase the safety factor for the application.

Backlash changes by different center height. Please contact APEX under WWW.APEXDYNA.COM.

Table 3. The max. permitted torque and feed-force of pinion Teeth Plate

Pinion \ Rack			Quality	Q4	Q5H	Q5		Q5 ⁺	Q6	Q6M	Q6C	Q8H	Q8	Q9	Q10	
			Material	Carbon Steel	Alloy Steel		Carbon Steel	Carbon Steel	Carbon Steel	Carbon Steel	Carbon Steel	Carbon Steel	Q&T Alloy Steel	Carbon Steel	Stainless Steel	Carbon Steel
			Heat Treatment	Induction Hardening	Case Hardening	Carburized Induction	Induction Hardening	Induction Hardening	Induction Hardening	Induction Hardening	Normalizing	Quenched Tempered	Normalizing	Solution	Induction Hardening	
Mn	z ⁽¹⁾	dw ⁽⁵⁾	Max. Torque * and Feed-Force													
2	26	56.8	$F_{2T}^{(8)}$ (N)		10,150	10,150			8,519	8,519	2,900	4,350	2,175		3,806	
			$T_{2B}^{(9)}$ (Nm)		280	280			235	235	80	120	60		105	
	27	57.296	$F_{2T}^{(8)}$ (N)		10,646	10,646			8,901	8,901	3,491	5,411	2,443		4,014	
			$T_{2B}^{(9)}$ (Nm)		305	305			255	255	100	155	70		115	
	29	63.2	$F_{2T}^{(8)}$ (N)		10,075	10,075			8,450	8,450	3,575	5,525	2,600		3,737	
			$T_{2B}^{(9)}$ (Nm)		310	310			260	260	110	170	80		115	
	33	71.599	$F_{2T}^{(8)}$ (N)		10,424	10,424			8,568	8,568	4,855	5,712	3,713		3,713	
			$T_{2B}^{(9)}$ (Nm)		365	365			300	300	170	200	130		130	
	35	75.8	$F_{2T}^{(8)}$ (N)		10,367	10,367			8,617	8,617	5,116	5,655	4,174		3,635	
			$T_{2B}^{(9)}$ (Nm)		385	385			320	320	190	210	155		135	
	36	76.394	$F_{2T}^{(8)}$ (N)		10,734	10,734			8,901	8,901	5,236	6,021	4,320		3,927	
			$T_{2B}^{(9)}$ (Nm)		410	410			340	340	200	230	165		150	
	37	80.2	$F_{2T}^{(8)}$ (N)		10,444	10,444			8,661	8,661	5,094	5,731	4,076		3,566	
			$T_{2B}^{(9)}$ (Nm)		410	410			340	340	200	225	160		140	
	40	86.4	$F_{2T}^{(8)}$ (N)		10,485	10,485			8,718	8,718	5,066	5,655	4,123		3,652	
			$T_{2B}^{(9)}$ (Nm)		445	445			370	370	215	240	175		155	
45	96.8	$F_{2T}^{(8)}$ (N)		10,577	10,577			8,796	8,796	5,131	5,760	4,189		3,560		
		$T_{2B}^{(9)}$ (Nm)		505	505			420	420	245	275	200		170		
3	30	95.493	$F_{2T}^{(8)}$ (N)		19,792	19,792		16,965	16,755	16,755	10,053	12,462	9,006		11,310	
			$T_{2B}^{(9)}$ (Nm)		945	945		810	800	800	480	595	430		540	
	31	100.8	$F_{2T}^{(8)}$ (N)		19,153	19,153		16,417	16,215	16,215	9,830	11,958	8,817		10,742	
			$T_{2B}^{(9)}$ (Nm)		945	945		810	800	800	485	590	435		530	
	35	113.6	$F_{2T}^{(8)}$ (N)		19,298	19,298		16,426	16,247	16,247	9,784	11,938	8,976		10,592	
			$T_{2B}^{(9)}$ (Nm)		1,075	1,075		915	905	905	545	665	500		590	
40	129.599	$F_{2T}^{(8)}$ (N)		15,708	15,708		13,509	13,273	13,273	8,090	9,817	7,383		8,718		
		$T_{2B}^{(9)}$ (Nm)		1,000	1,000		860	845	845	515	625	470		555		
4	30	127.324	$F_{2T}^{(8)}$ (N)		36,128		31,102	31,102	31,023	31,023	19,007	23,562	17,514		22,070	
			$T_{2B}^{(9)}$ (Nm)		2,300		1,980	1,980	1,975	1,975	1,210	1,500	1,115		1,405	
	38	163.2	$F_{2T}^{(8)}$ (N)		37,079		31,871	31,871	31,809	31,809	19,718	24,492	18,229		22,508	
			$T_{2B}^{(9)}$ (Nm)		2,890		2,570	2,570	2,565	2,565	1,590	1,975	1,470		1,815	
5	21	111.409	$F_{2T}^{(8)}$ (N)	47,483	55,112		47,483	47,483	47,393	47,393			17,683		37,609	
			$T_{2B}^{(9)}$ (Nm)	2,645	3,070		2,645	2,645	2,640	2,640			985		2,095	
	36	190.986	$F_{2T}^{(8)}$ (N)	52,360	60,894		52,360	52,360	52,360	52,360			31,782		42,045	
			$T_{2B}^{(9)}$ (Nm)	5,000	5,815		5,000	5,000	5,000	5,000			3,035		4,015	

* The Maximal Driving Torque is also to be understood as the Maximal Acceleration Torque T_{2B} .

The Emergency Stop Torque $T_{2NOT} = 2 \times T_{2B}$, under the condition limited 1000 times in the whole service period.

(1) Number of Teeth (5) Working Pitch Circle Diameter (in mm) (8) Maximum Feed-Force (9) Maximum Driving Torque

Pinion with Helical Teeth

(Interface : DIN 5480 / Spline)

Quality DIN 5 / Alloy Steel
 Tooth Thickness Tolerance : e24
 Left-Hand Helical Teeth
 Case-Hardened and Teeth Ground

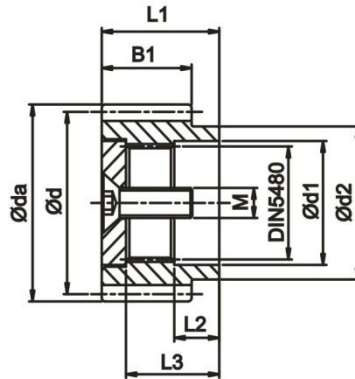

DIN 5480	Mn	z ⁽¹⁾	x ⁽²⁾	da ⁽³⁾	d ⁽⁴⁾	dw ⁽⁵⁾	B1	L1	d1	d2	L2	L3	L ⁽⁶⁾	M	Order code
N16x0.8x30x18x7H	2	15	0.592	38.20	31.831	34.200	26	32	16	26	11	26.5	100.000	M5x15	D02L15N16
		16	0.612	40.40	33.953	36.400	26	32	16	28	11	26.5	106.667	M5x15	D02L16N16
		18	0.500	44.20	38.197	40.200	26	32	16	32	11	26.5	120.000	M5x15	D02L18N16
N22x1.25x30x16x7H	1.5	38	0.000	63.48	60.479	60.480	20	33	22	32	12	27.5	190.000	M8x25	D1JL38N22
		18	0.500	44.20	38.197	40.200	26	33	22	32	12	27.5	120.000	M8x25	D02L18N22
	2	20	0.490	48.40	42.441	44.400	26	33	22	34	12	27.5	133.334	M8x25	D02L20N22
		22	0.479	52.60	46.686	48.600	26	33	22	36	12	27.5	146.667	M8x25	D02L22N22
N32x1.25x30x24x7H	2	25	0.000	57.52	53.052	53.052	26	33	22	36	12	27.5	166.667	M8x25	D02L25N22
		23	0.498	54.80	48.808	50.800	26	34	32	42	13	27.0	153.334	M12x30	D02L23N32
		25	0.487	59.00	53.052	55.000	26	34	32	45	13	27.0	166.667	M12x30	D02L25N32
N40x2x30x18x7H	3	27	0.376	62.80	57.296	58.800	26	34	32	48	13	27.0	180.000	M12x30	D02L27N32
		20	0.456	72.40	63.662	66.400	31	51	40	55	20	41.0	200.000	M16x40	D03L20N40
		22	0.462	78.80	70.028	72.800	31	51	40	58	20	41.0	220.000	M16x40	D03L22N40
N55x2x30x26x7H	4	24	0.468	85.20	76.394	79.200	31	51	40	62	20	41.0	240.000	M16x40	D03L24N40
		20	0.400	96.08	84.883	88.080	41	54	55	75	20	44.0	266.667	M20x50	D04L20N55
		25	0.340	116.82	106.103	108.820	41	65	75	94	24	55.0	333.334	M20x50	D04L25N70
N80x2x30x38x7H	5	24	0.348	104.80	127.324	130.800	51	73	85	110	24	62.5	400.000	M20x50	D05L24N80

- (1) Number of teeth (2) Profile modification factor (3) Diameter of addendum circle (4) Pitch circle diameter
 (5) Working pitch circle diameter (6) Pitch circle length $L = \pi \times d$

Pinion material carburized, the surface hardness reaches to 60 HRc after case hardening
 Teeth surface ground in order to reduce noise and improve wear resistance
 Accessories include washers and hex head socket head cap screws (Strength 8.8 · ISO 10642 / DIN 7991)

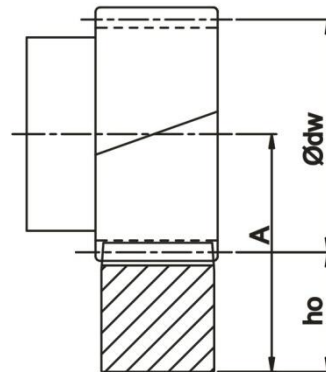
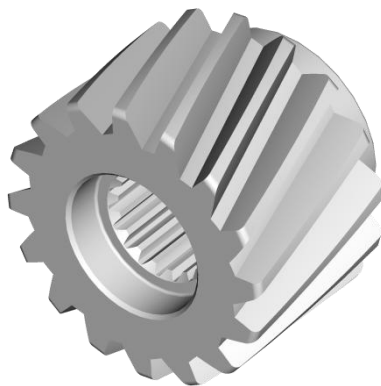

$$A = h_o + \frac{\phi dw}{2}$$

In Table 4, the maximum permissible torque of pinion with DIN 5480, and the rack is calculated on the basis of a speed of 1.5 m/s and providing good lubrication (using an automatic lubrication system or manually applied grease every day), the tooth root strength factor $S_F \geq 1.4$, tooth surface strength coefficient $S_H \geq 1$, the safety factor $S_B \approx 1$, and the required service life of 20,000 hours. By higher speed, the max. permissible torque reduced. The user needs to increase the safety factor for the application. Backlash changes by different center height. Please contact APEX under WWW.APEXDYNA.COM.

Table 4. The max. permitted torque and feed-force of pinion with DIN 5480

Pinion			Rack		Quality	Q4	Q5H	Q5		Q5*	Q6	Q6M	Q6C	Q8H	Q8	Q9	Q10	
			Material	Carbon Steel	Alloy Steel		Carbon Steel	Carbon Steel	Carbon Steel	Carbon Steel	Carbon Steel	Carbon Steel	Carbon Steel	Carbon Steel	Q&T Alloy Steel	Carbon Steel	Stainless Steel	Carbon Steel
			Heat Treatment	Induction Hardening	Case Hardening	Carburized Induction	Induction Hardening	Induction Hardening	Induction Hardening	Induction Hardening	Induction Hardening	Normalizing	Quenched Tempered	Normalizing	Solution	Induction Hardening		
Mn	z ⁽¹⁾	dw ⁽⁵⁾	Max. Torque * and Feed-Force															
1.5	38	60.48	F _{2T} ⁽⁸⁾ (N)							5,622		3,142		1,984			1,653	
			T _{2B} ⁽⁹⁾ (Nm)								170		95		60			50
2	15	34.2	F _{2T} ⁽⁸⁾ (N)		8,482	8,482				8,168	8,168	1,571	2,199	1,571			3,456	
			T _{2B} ⁽⁹⁾ (Nm)		135	135				130	130	25	35	25			55	
	16	36.4	F _{2T} ⁽⁸⁾ (N)		9,130	9,130				8,541	8,541	2,061	2,651	1,767			4,418	
			T _{2B} ⁽⁹⁾ (Nm)		155	155				145	145	35	45	30			75	
	18	40.2	F _{2T} ⁽⁸⁾ (N)		10,472	10,472				8,901	8,901	2,356	3,665	2,094			4,974	
			T _{2B} ⁽⁹⁾ (Nm)		200	200				170	170	45	70	40			95	
	20	44.4	F _{2T} ⁽⁸⁾ (N)		9,896	9,896				8,247	8,247	1,885	2,356	1,649			4,006	
			T _{2B} ⁽⁹⁾ (Nm)		210	210				175	175	40	50	35			85	
	22	48.6	F _{2T} ⁽⁸⁾ (N)		9,853	9,853				8,354	8,354	2,142	2,999	1,714			4,070	
			T _{2B} ⁽⁹⁾ (Nm)		230	230				195	195	50	70	40			95	
	23	50.8	F _{2T} ⁽⁸⁾ (N)		10,039	10,039				8,195	8,195	2,254	3,278	1,843			3,893	
			T _{2B} ⁽⁹⁾ (Nm)		245	245				200	200	55	80	45			95	
	25	53.052	F _{2T} ⁽⁸⁾ (N)		10,744	10,744				8,859	8,859	3,016	4,712	2,262			4,524	
			T _{2B} ⁽⁹⁾ (Nm)		285	285				235	235	80	125	60			120	
	25	55	F _{2T} ⁽⁸⁾ (N)		9,990	9,990				8,294	8,294	2,639	3,958	2,073			3,958	
			T _{2B} ⁽⁹⁾ (Nm)		265	265				220	220	70	105	55			105	
	27	58.8	F _{2T} ⁽⁸⁾ (N)		10,297	10,297				8,552	8,552	3,142	4,887	2,269			3,840	
			T _{2B} ⁽⁹⁾ (Nm)		295	295				245	245	90	140	65			110	
	3	20	66.4	F _{2T} ⁽⁸⁾ (N)		18,378	18,378		15,865	15,551	15,551	4,398	6,754	3,142			10,681	
				T _{2B} ⁽⁹⁾ (Nm)		585	585		505	495	495	140	215	100			340	
22		72.8	F _{2T} ⁽⁸⁾ (N)		18,564	18,564		15,851	15,708	15,708	5,426	8,140	3,998			10,567		
			T _{2B} ⁽⁹⁾ (Nm)		650	650		555	550	550	190	285	140			370		
24		79.2	F _{2T} ⁽⁸⁾ (N)		18,588	18,588		15,970	15,708	15,708	6,414	9,687	4,974			10,603		
			T _{2B} ⁽⁹⁾ (Nm)		710	710		610	600	600	245	370	190			405		
4	20	88.08	F _{2T} ⁽⁸⁾ (N)		33,340		28,628	28,628	28,628	28,628	9,896	14,726	7,304			20,381		
			T _{2B} ⁽⁹⁾ (Nm)		1,415		1,215	1,215	1,215	1,215	420	625	310			865		
	25	108.82	F _{2T} ⁽⁸⁾ (N)		34,118		29,311	29,311	29,217	29,217	14,514	21,865	12,064			20,546		
			T _{2B} ⁽⁹⁾ (Nm)		1,810		1,555	1,555	1,550	1,550	770	1,160	640			1,090		
5	24	130.8	F _{2T} ⁽⁸⁾ (N)	46,731	54,271		46,731	46,731	46,653	46,653				20,656		36,521		
			T _{2B} ⁽⁹⁾ (Nm)	2,975	3,455		2,975	2,975	2,970	2,970				1,315		2,325		

* The Maximal Driving Torque is also to be understood as the Maximal Acceleration Torque T_{2B}.
 The Emergency Stop Torque T_{2NOT} = 2 x T_{2B}, under the condition limited 1000 times in the whole service period.

(1) Number of Teeth (5) Working Pitch Circle Diameter (in mm) (8) Maximum Feed-Force (9) Maximum Driving Torque

Pinion with Helical Teeth

(Interface : Keyway for APEX AF / KF / AE / PII-Series)

Quality DIN 5 / Alloy Steel

Tooth Thickness Tolerance : e25

Left-Hand Helical Teeth

Case-Hardened and Teeth Ground

Combine with AF / KF Series gearbox

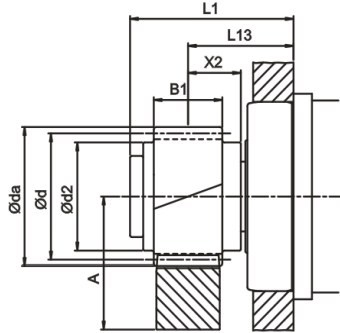

Gearbox	Mn	z ⁽¹⁾	x ⁽²⁾	da ⁽³⁾	d ⁽⁴⁾	dw ⁽⁵⁾	d2	B1	L1	L13	X2	L ⁽⁶⁾	Order code
AF/AFR060 KF 060	2	18	0.401	43.8	38.197	39.8	30	26	54	39	19	120.000	E02L18
AF/AFR075 KF 075	2	22	0.179	51.4	46.686	47.4	40	26	63	40	20	146.667	E02L22
AF/AFR100 KF 100	2	26	0.007	59.2	55.174	55.2	46	26	96	51	21	173.334	E02L26
AF/AFR140 KF 140	3	24	0.001	82.4	76.394	76.4	62	31	122	65.5	35.5	240.000	E03L24

Combine with AE / PEII Series gearbox

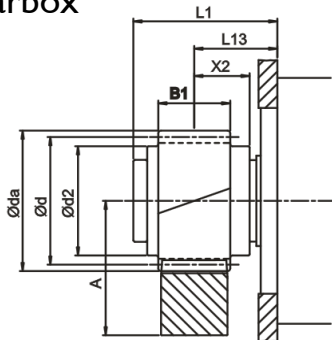

Gearbox	Mn	z ⁽¹⁾	x ⁽²⁾	da ⁽³⁾	d ⁽⁴⁾	dw ⁽⁵⁾	d2	B1	L1	L13	X2	L ⁽⁶⁾	Order code
AE / AER 070	2	18	0.401	43.8	38.197	39.8	30	26	41.5	26.5	19	120.000	E02L18
PEII / PEIIR 070									42	27			
AE / AER 090	2	22	0.179	51.4	46.686	47.4	40	26	52.5	29.5	20	146.667	E02L22
PEII / PEIIR 090									53	30			
AE / AER 120	2	26	0.007	59.2	55.174	55.2	46	26	85	40	21	173.334	E02L26
PEII / PEIIR 120									78	33			
AE / AER 155	3	24	0.001	82.4	76.394	76.4	62	31	110	53.5	35.5	240.000	E03L24
PEII / PEIIR 155									107	50.5			

(1) Number of teeth (2) Profile modification factor (3) Diameter of addendum circle (4) Pitch circle diameter
 (5) Working pitch circle diameter (6) Pitch circle length $L = \pi \times d$

Pinion material carburized, the surface hardness reaches to 60 HRC after case hardening

Teeth surface ground in order to reduce noise and improve wear resistance

Accessories include hexagon socket head cap screws (Strength 12.9 , DIN 912)

Pinion with Helical Teeth

(Interface : Keyway)

Quality DIN 5 / Alloy Steel
 Tooth Thickness Tolerance : e25
 Left-Hand Helical Teeth
 Case-Hardened and Teeth Ground

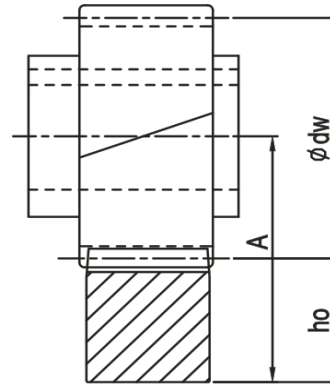
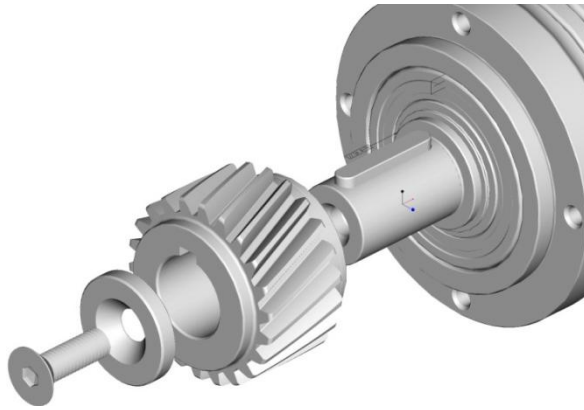

$$A = h_0 + \frac{\phi dw}{2}$$

In table 5, the maximum permissible torque of pinion with Keyway for APEX AF / KF / AE / PII - Gearbox, and the rack is calculated on the basis of a speed of 1.5 m/s and providing good lubrication (using an automatic lubrication system or manually applied grease every day), the tooth root strength factor $S_F \geq 1.4$, tooth surface strength coefficient $S_H \geq 1$, the safety factor $S_B \cong 1$, and the required service life of 20,000 hours. By higher speed, the max. permissible torque reduced. The user needs to increase the safety factor for the application. Backlash changes by different center height. Please contact APEX under WWW.APEXDYNA.COM.

Table 5, the max. permitted torque and feed-force of pinion with Keyway for APEX AF / KF / AE / PII-Series

Pinion	Rack		Quality	Q4	Q5H	Q5	Q5 ⁺	Q6	Q6M	Q6C	Q8H	Q8	Q9	Q10	
			Material	Carbon Steel	Alloy Steel		Carbon Steel	Carbon Steel	Carbon Steel	Carbon Steel	Carbon Steel	Q&T Alloy Steel	Carbon Steel	Stainless Steel	Carbon Steel
			Heat Treatment	Induction Hardening	Case Hardening	Carburized Induction	Induction Hardening	Induction Hardening	Induction Hardening	Induction Hardening	Normalizing	Quenched Tempered	Normalizing	Solution	Induction Hardening
Mn	z ⁽¹⁾	dw ⁽⁵⁾	Max. Torque * and Feed-Force												
2	18	39.8	F _{2T} ⁽⁸⁾ (N)		10,734	10,734			9,163	9,163	2,356	3,665	2,094		4,974
			T _{2B} ⁽⁹⁾ (Nm)		205	205			175	175	45	70	40		95
	22	47.4	F _{2T} ⁽⁸⁾ (N)		10,496	10,496			8,568	8,568	2,142	3,213	1,928		4,284
			T _{2B} ⁽⁹⁾ (Nm)		245	245			200	200	50	75	45		100
	26	55.2	F _{2T} ⁽⁸⁾ (N)		10,693	10,693			8,881	8,881	3,262	4,894	2,356		4,350
			T _{2B} ⁽⁹⁾ (Nm)		295	295			245	245	90	135	65		120
3	24	76.4	F _{2T} ⁽⁸⁾ (N)		19,635	19,635		16,886	16,624	16,624	7,199	10,864	5,760		11,650
			T _{2B} ⁽⁹⁾ (Nm)		750	750		645	635	635	275	415	220		445

* The Maximal Driving Torque is also to be understood as the Maximal Acceleration Torque T_{2B}.

The Emergency Stop Torque T_{2NOT} = 2 x T_{2B}, under the condition limited 1000 times in the whole service period.

(1) Number of Teeth (5) Working Pitch Circle Diameter (in mm) (8) Maximum Feed-Force (9) Maximum Driving Torque

Pinion with Helical Teeth

(Interface : Keyway)

Quality DIN 5 / Alloy Steel
 Tooth Thickness Tolerance : e25 *
 Left-Hand Helical Teeth
 Case-Hardened and Teeth Ground

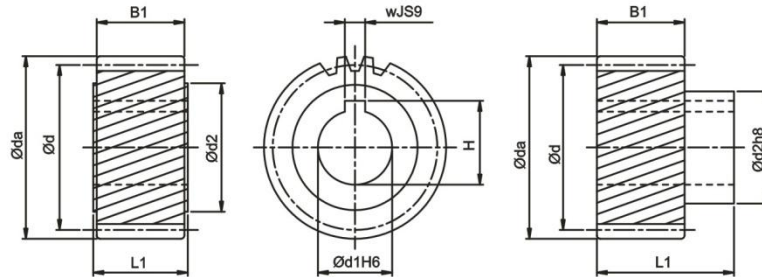

Fig. A

Fig. B

Module 1

z ⁽¹⁾	x ⁽²⁾	da ⁽³⁾	d ⁽⁴⁾	dw ⁽⁵⁾	d1 _{H6}	d2	B1	L1	w _{JS9}	H	L ⁽⁶⁾	Fig	Order code	
													Pinion	Shrink Disc
30	0	33.831	31.831	31.831	12	22	17	19	4	13.8	100	A	F01L30A12	
30	0	33.831	31.831	31.831	13	22	17	19	5	15.3	100	A	F01L30A13	

Module 1.5

z ⁽¹⁾	x ⁽²⁾	da ⁽³⁾	d ⁽⁴⁾	dw ⁽⁵⁾	d1 _{H6}	d2	B1	L1	w _{JS9}	H	L ⁽⁶⁾	Fig	Order code	
													Pinion	Shrink Disc
20	0	34.831	31.831	31.831	11	25	20	22	4	12.8	100	A	FIJL20A11	
20	0	34.831	31.831	31.831	14	25	20	22	5	16.3	100	A	FIJL20A14	
20	0	34.831	31.831	31.831	16	25	20	22	5	18.3	100	A	FIJL20A16	
21	0	36.423	33.423	33.423	16	30	20	46	5	18.3	105	B	FIJL21B16	SSD-30

Module 2

z ⁽¹⁾	x ⁽²⁾	da ⁽³⁾	d ⁽⁴⁾	dw ⁽⁵⁾	d1 _{H6}	d2	B1	L1	w _{JS9}	H	L ⁽⁶⁾	Fig	Order code	
													Pinion	Shrink Disc
18	0	42.197	38.197	38.197	16	25	28	30	5	18.3	120	A	F02L18A16	
20	0	46.441	42.441	42.441	19	30	28	30	6	21.8	133.334	A	F02L20A19	
20	0	46.441	42.441	42.441	19	30	28	56	6	21.8	133.334	B	F02L20B19	SSD-30
20	0	46.441	42.441	42.441	20	30	28	30	6	22.8	133.334	A	F02L20A20	
20	0	46.441	42.441	42.441	22	30	28	30	6	24.8	133.334	A	F02L20A22	
20	0	46.441	42.441	42.441	22	36	28	56	6	24.8	133.334	B	F02L20B22	SSD-36
21	0	48.563	44.563	44.563	16	25	28	30	5	18.3	140	A	F02L21A16	
21	0	48.563	44.563	44.563	22	36	28	56	6	24.8	140	B	F02L21B22	SSD-36
22	0	50.686	46.686	46.686	19	30	28	30	6	21.8	146.667	A	F02L22A19	
22	0	50.686	46.686	46.686	19	30	28	56	6	21.8	146.667	B	F02L22B19	SSD-30
22	0	50.686	46.686	46.686	22	30	28	30	6	24.8	146.667	A	F02L22A22	
22	0	50.686	46.686	46.686	22	36	28	56	6	24.8	146.667	B	F02L22B22	SSD-36
25	0	57.052	53.052	53.052	19	30	28	30	6	21.8	166.667	A	F02L25A19	
25	0	57.052	53.052	53.052	19	30	28	56	6	21.8	166.667	B	F02L25B19	SSD-30
25	0	57.052	53.052	53.052	20	30	28	30	6	22.8	166.667	A	F02L25A20	
25	0	57.052	53.052	53.052	22	30	28	30	6	24.8	166.667	A	F02L25A22	
25	0	57.052	53.052	53.052	22	36	28	56	6	24.8	166.667	B	F02L25B22	SSD-36
25	0	57.052	53.052	53.052	25	36	28	30	8	28.3	166.667	A	F02L25A25	

* By Module 1.5, the Tooth Thickness Tolerance = f 24.

- (1) Number of teeth (2) Profile modification factor (3) Diameter of addendum circle (4) Pitch circle diameter
 (5) Working pitch circle diameter (6) Pitch circle length $L = \pi \times d$

Quality DIN 5 / Alloy Steel
 Tooth Thickness Tolerance : e25
 Left-Hand Helical Teeth
 Case-Hardened and Teeth Ground

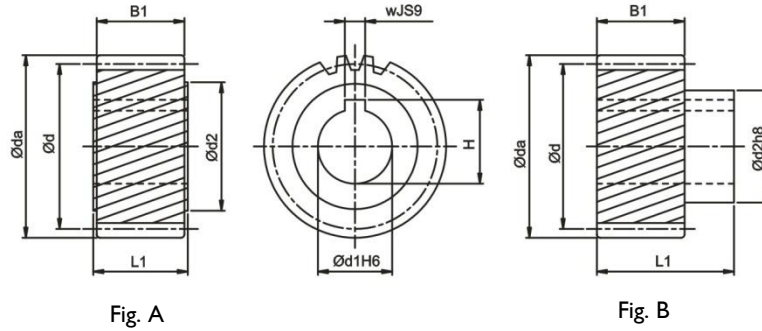

Module 2

z ⁽¹⁾	x ⁽²⁾	da ⁽³⁾	d ⁽⁴⁾	dw ⁽⁵⁾	dI _{H6}	d2	B1	L1	w _{JS9}	H	L ⁽⁶⁾	Fig	Order code	
													Pinion	Shrink Disc
28	0	63.418	59.418	59.418	19	30	28	30	6	21.8	186.667	A	F02L28A19	
28	0	63.418	59.418	59.418	19	30	28	56	6	21.8	186.667	B	F02L28B19	SSD-30
28	0	63.418	59.418	59.418	22	30	28	30	6	24.8	186.667	A	F02L28A22	
28	0	63.418	59.418	59.418	22	36	28	56	6	24.8	186.667	B	F02L28B22	SSD-36
28	0	63.418	59.418	59.418	35	48	28	30	10	38.3	186.667	A	F02L28A35	
30	0	67.662	63.662	63.661	16	25	28	30	5	18.3	200	A	F02L30A16	
30	0	67.662	63.662	63.661	20	30	28	30	6	22.8	200	A	F02L30A20	
30	0	67.662	63.662	63.661	22	36	28	56	6	24.8	200	B	F02L30B22	SSD-36
30	0	67.662	63.662	63.661	25	36	28	30	8	28.3	200	A	F02L30A25	
30	0	67.662	63.662	63.661	30	45	28	30	8	33.3	200	A	F02L30A30	
30	0	67.662	63.662	63.661	30	50	28	60	8	33.3	200	B	F02L30B30	SSD-50
30	0	67.662	63.662	63.661	32	55	28	65	10	35.3	200	B	F02L30B32	SSD-55
32	0	71.906	67.906	67.906	20	30	28	30	6	22.8	213.334	A	F02L32A20	
32	0	71.906	67.906	67.906	22	30	28	30	6	24.8	213.334	A	F02L32A22	
32	0	71.906	67.906	67.906	22	36	28	56	6	24.8	213.334	B	F02L32B22	SSD-36
32	0	71.906	67.906	67.906	25	36	28	30	8	28.3	213.334	A	F02L32A25	
32	0	71.906	67.906	67.906	35	48	28	30	10	38.3	213.334	A	F02L32A35	
36	0	80.394	76.394	76.394	35	48	28	30	10	38.3	240	A	F02L36A35	
39	0	86.761	82.761	82.761	32	55	28	65	10	35.3	260	B	F02L39B32	SSD-55
40	0	88.883	84.883	84.883	35	48	28	30	10	38.3	266.667	A	F02L40A35	

Module 2.5

z ⁽¹⁾	x ⁽²⁾	da ⁽³⁾	d ⁽⁴⁾	dw ⁽⁵⁾	dI _{H6}	d2	B1	L1	w _{JS9}	H	L ⁽⁶⁾	Fig	Order code	
													Pinion	Shrink Disc
24	0	68.662	63.662	63.662	25	36	28	30	8	28.3	200	A	F2JL24A25	
24	0	68.662	63.662	63.662	25	44	28	60	8	28.3	200	B	F2JL24B25	SSD-44

Pinion with Helical Teeth

(Interface : Keyway)

Quality DIN 5 / Alloy Steel
 Tooth Thickness Tolerance : e25
 Left-Hand Helical Teeth
 Case-Hardened and Teeth Ground

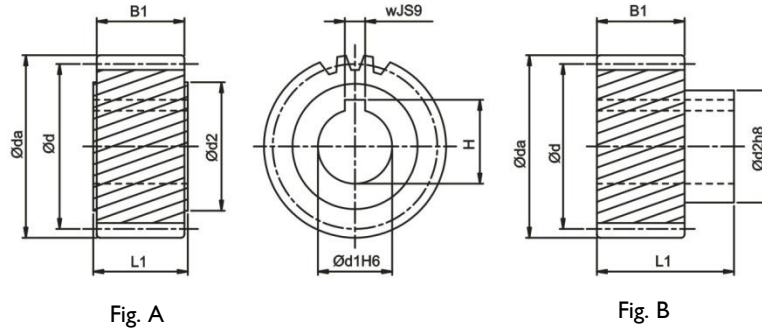

Module 3

z ⁽¹⁾	x ⁽²⁾	da ⁽³⁾	d ⁽⁴⁾	dw ⁽⁵⁾	d1 _{H6}	d2	B1	L1	w _{JS9}	H	L ⁽⁶⁾	Fig	Order code	
													Pinion	Shrink Disc
20	0	69.661	63.662	63.662	22	36	28	56	6	24.8	200	B	F03L20B22	SSD-36
20	0	69.661	63.662	63.662	25	44	28	60	8	28.3	200	B	F03L20B25	SSD-44
20	0	69.661	63.662	63.662	30	45	28	30	8	33.3	200	A	F03L20A30	
20	0	69.661	63.662	63.662	30	50	28	60	8	33.3	200	B	F03L20B30	SSD-50
20	0	69.661	63.662	63.662	32	55	28	65	10	35.3	200	B	F03L20B32	SSD-55
20	0	69.661	63.662	63.662	35	48	28	30	10	38.3	200	A	F03L20A35	
22	0	76.028	70.028	70.028	25	36	28	30	8	28.3	220	A	F03L22A25	
22	0	76.028	70.028	70.028	30	45	28	30	8	33.3	220	A	F03L22A30	
22	0	76.028	70.028	70.028	32	55	28	65	10	35.3	220	B	F03L22B32	SSD-55
22	0	76.028	70.028	70.028	35	48	28	30	10	38.3	220	A	F03L22A35	
22	0	76.028	70.028	70.028	40	62	28	65	12	43.3	220	B	F03L22B40	SSD-62
25	0	85.578	79.578	79.578	22	36	28	56	6	24.8	250	B	F03L25B22	SSD-36
25	0	85.578	79.578	79.578	25	44	28	30	8	28.3	250	A	F03L25A25	
25	0	85.578	79.578	79.578	25	44	28	60	8	28.3	250	B	F03L25B25	SSD-44
25	0	85.578	79.578	79.578	30	45	28	30	8	33.3	250	A	F03L25A30	
25	0	85.578	79.578	79.578	30	50	28	60	8	33.3	250	B	F03L25B30	SSD-50
25	0	85.578	79.578	79.578	32	55	28	65	10	35.3	250	B	F03L25B32	SSD-55
25	0	85.578	79.578	79.578	35	48	28	30	10	38.3	250	A	F03L25A35	
25	0	85.578	79.578	79.578	35	55	28	65	10	38.3	250	B	F03L25B35	SSD-55
25	0	85.578	79.578	79.578	40	62	28	65	12	43.3	250	B	F03L25B40	SSD-62
25	0	85.578	79.578	79.578	40	70	28	50	12	43.3	250	A	F03L25A40	
28	0	95.127	89.127	89.127	32	55	28	65	10	35.3	280	B	F03L28B32	SSD-55
28	0	95.127	89.127	89.127	40	62	28	65	12	43.3	280	B	F03L28B40	SSD-62
32	0	107.859	101.859	101.859	32	55	28	65	10	35.3	320	B	F03L32B32	SSD-55
32	0	107.859	101.859	101.859	40	62	28	65	12	43.3	320	B	F03L32B40	SSD-62

Module 4

z ⁽¹⁾	x ⁽²⁾	da ⁽³⁾	d ⁽⁴⁾	dw ⁽⁵⁾	d1 _{H6}	d2	B1	L1	w _{JS9}	H	L ⁽⁶⁾	Fig	Order code	
													Pinion	Shrink Disc
15	0	71.662	63.662	63.662	35	52	40	50	10	38.3	200.000	A	F04L15A35	
18	0	84.394	76.394	76.394	32	55	40	75	10	35.3	240.000	B	F04L18B32	SSD-55
20	0	92.883	84.883	84.883	35	52	40	50	10	38.3	266.667	A	F04L20A35	
20	0	92.883	84.883	84.883	45	65	40	50	14	48.8	266.667	A	F04L20A45	
21	0	97.127	89.127	89.127	32	55	40	75	10	35.3	280.000	B	F04L21B32	SSD-55
21	0	97.127	89.127	89.127	35	55	40	75	10	38.3	280.000	B	F04L21B35	SSD-55
21	0	97.127	89.127	89.127	40	62	40	75	12	43.3	280.000	B	F04L21B40	SSD-62
21	0	97.127	89.127	89.127	45	68	40	75	14	48.8	280.000	B	F04L21B45	SSD-68

(1) Number of teeth (2) Profile modification factor (3) Diameter of addendum circle (4) Pitch circle diameter
 (5) Working pitch circle diameter (6) Pitch circle length $L = \pi \times d$

Quality DIN 5 / Alloy Steel
 Tooth Thickness Tolerance : e25
 Left-Hand Helical Teeth
 Case-Hardened and Teeth Ground

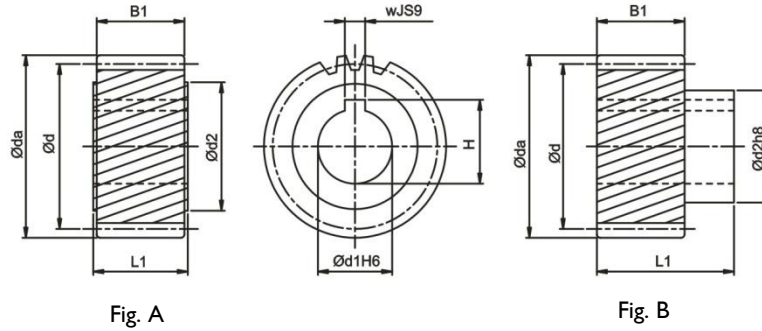

Module 4

z ⁽¹⁾	x ⁽²⁾	da ⁽³⁾	d ⁽⁴⁾	dw ⁽⁵⁾	d1 _{H6}	d2	B1	L1	w _{JS9}	H	L ⁽⁶⁾	Fig	Order code	
													Pinion	Shrink Disc
22	0	101.371	93.371	93.371	35	52	40	50	10	38.3	293.334	A	F04L22A35	
22	0	101.371	93.371	93.371	45	65	40	50	14	48.8	293.334	A	F04L22A45	
24	0	109.859	101.859	101.859	32	55	40	75	10	35.3	320.000	B	F04L24B32	SSD-55
24	0	109.859	101.859	101.859	35	55	40	75	10	38.3	320.000	B	F04L24B35	SSD-55
24	0	109.859	101.859	101.859	40	62	40	75	12	43.3	320.000	B	F04L24B40	SSD-62
24	0	109.859	101.859	101.859	45	68	40	75	14	48.8	320.000	B	F04L24B45	SSD-68
24	0	109.859	101.859	101.859	55	80	40	80	16	59.3	320.000	B	F04L24B55	SSD-80
25	0	114.103	106.103	106.103	35	52	40	50	10	38.3	333.334	A	F04L25A35	
25	0	114.103	106.103	106.103	45	65	40	50	14	48.8	333.334	A	F04L25A45	
25	0	114.103	106.103	106.103	55	80	40	80	16	59.3	333.334	B	F04L25B55	SSD-80

Module 5

z ⁽¹⁾	x ⁽²⁾	da ⁽³⁾	d ⁽⁴⁾	dw ⁽⁵⁾	d1 _{H6}	d2	B1	L1	w _{JS9}	H	L ⁽⁶⁾	Fig	Order code	
													Pinion	Shrink Disc
18	0	105.493	95.493	95.493	45	68	50	85	14	48.8	300	B	F05L18B45	SSD-68
24	0	137.324	127.324	127.324	45	68	50	85	14	48.8	400	B	F05L24B45	SSD-68
24	0	137.324	127.324	127.324	55	80	50	90	16	59.3	400	B	F05L24B55	SSD-80
24	0	137.324	127.324	127.324	75	110	50	110	20	79.9	400	B	F05L24B75	SSD-110

Module 6

z ⁽¹⁾	x ⁽²⁾	da ⁽³⁾	d ⁽⁴⁾	dw ⁽⁵⁾	d1 _{H6}	d2	B1	L1	w _{JS9}	H	L ⁽⁶⁾	Fig	Order code	
													Pinion	Shrink Disc
20	0	139.324	127.324	127.324	55	80	60	100	16	59.3	400	B	F06L20B55	SSD-80
20	0	139.324	127.324	127.324	75	110	60	120	20	79.9	400	B	F06L20B75	SSD-110
25	0	171.155	159.155	159.155	55	80	60	100	16	59.3	500	B	F06L25B55	SSD-80
25	0	171.155	159.155	159.155	75	110	60	120	20	79.9	500	B	F06L25B75	SSD-110

Pinion with Helical Teeth

(Interface : Keyway)

Quality DIN 5 / Alloy Steel
 Tooth Thickness Tolerance : e25 **
 Left-Hand Helical Teeth
 Case-Hardened and Teeth Ground

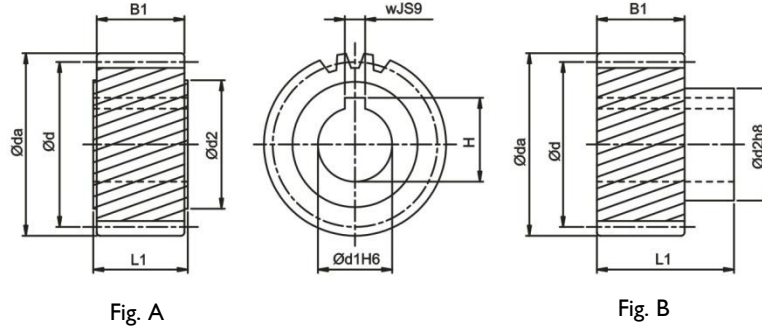

Module 8

z ⁽¹⁾	x ⁽²⁾	da ⁽³⁾	d ⁽⁴⁾	dw ⁽⁵⁾	d1 _{H6}	d2	B1	L1	w _{JS9}	H	L ⁽⁶⁾	Fig	Order code	
													Pinion	Shrink Disc
18	0	168.789	152.789	152.789	75	110	80	140	20	79.9	480.000	B	F08L18B75	SSD-110
20	0	185.766	169.766	169.766	85	125	80	145	22	90.4	533.334	B	F08L20B85	SSD-125

Module 10

z ⁽¹⁾	x ⁽²⁾	da ⁽³⁾	d ⁽⁴⁾	dw ⁽⁵⁾	d1 _{H6}	d2	B1	L1	w _{JS9}	H	L ⁽⁶⁾	Fig	Order code	
													Pinion	Shrink Disc
20	0	232.207	212.207	212.207	85	125	100	165	22	90.4	666.668	B	F10L20B85	SSD-125

** By Module 8 and 10, the Tooth Thickness Tolerance = f 23. (1) Number of teeth (2) Profile modification factor
 (3) Diameter of addendum circle (4) Pitch circle diameter (5) Working pitch circle diameter (6) Pitch circle length $L = \pi \times d$

Pinion material carburized, the surface hardness reaches to 60 HRc after case hardening
 Teeth surface ground in order to reduce noise and improve wear resistance

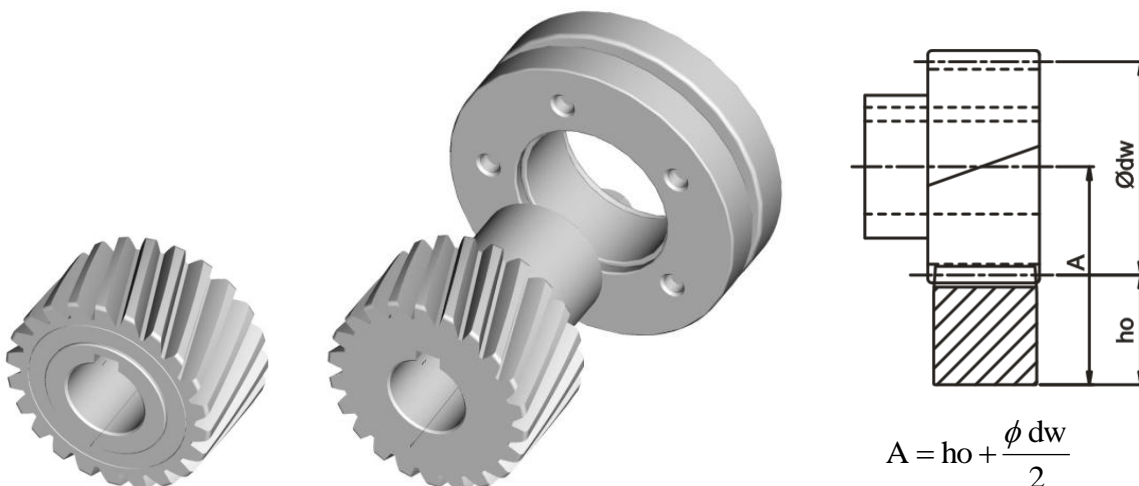

In Table 6, the maximum permissible torque of pinion with Keyway, and the rack is calculated on the basis of a speed of 1.5 m/s and providing good lubrication (using an automatic lubrication system or manually applied grease every day), the tooth root strength factor $S_f \geq 1.4$, tooth surface strength coefficient $S_H \geq 1$, the safety factor $S_B \cong 1$, and the required service life of 20,000 hours. By higher speed, the max. permissible torque reduced. The user needs to increase the safety factor for the application. Backlash changes by different center height. Please contact APEX under WWW.APEXDYNA.COM.

Table 6. The max. permitted torque and feed-force of pinion with Keyway

Pinion			Rack		Quality	Q4	Q5H	Q5		Q5 ⁺	Q6	Q6M	Q6C	Q8H	Q8	Q9	Q10	
			Material		Carbon Steel	Alloy Steel		Carbon Steel	Carbon Steel	Carbon Steel	Carbon Steel	Carbon Steel	Carbon Steel	Carbon Steel	Q&T Alloy Steel	Carbon Steel	Stainless Steel	Carbon Steel
			Heat Treatment		Induction Hardening	Case Hardening	Carburized Induction	Induction Hardening	Induction Hardening	Induction Hardening	Induction Hardening	Induction Hardening	Normalizing	Quenched Tempered	Normalizing	Solution	Induction Hardening	
Mn	z ⁽¹⁾	dw ⁽⁵⁾	Max. Torque* and Feed-Force															
I	30	31.831	F _{2T} ⁽⁸⁾ (N)							2,199			942					
			T _{2B} ⁽⁹⁾ (Nm)								35			15				
1.5	20	31.831	F _{2T} ⁽⁸⁾ (N)							5,027			942		628		1,257	
			T _{2B} ⁽⁹⁾ (Nm)								80			15		10		20
	21	33.423	F _{2T} ⁽⁸⁾ (N)							5,086			898		598		1,197	
			T _{2B} ⁽⁹⁾ (Nm)								85			15		10		20
2	18	38.197	F _{2T} ⁽⁸⁾ (N)		11,257	11,257				9,163	9,163	2,094	2,880	1,833		2,880		
			T _{2B} ⁽⁹⁾ (Nm)		215	215				175	175	40	55	35		55		
	20	42.441	F _{2T} ⁽⁸⁾ (N)		10,367	10,367				8,247	8,247	1,649	2,121	1,414		2,356		
			T _{2B} ⁽⁹⁾ (Nm)		220	220				175	175	35	45	30		50		
	21	44.563	F _{2T} ⁽⁸⁾ (N)		10,547	10,547				8,303	8,303	1,795	2,244	1,346		2,468		
			T _{2B} ⁽⁹⁾ (Nm)		235	235				185	185	40	50	30		55		
	22	46.686	F _{2T} ⁽⁸⁾ (N)		10,496	10,496				8,354	8,354	1,928	2,356	1,499		2,356		
			T _{2B} ⁽⁹⁾ (Nm)		245	245				195	195	45	55	35		55		
	25	53.052	F _{2T} ⁽⁸⁾ (N)		10,556	10,556				8,294	8,294	2,262	3,204	1,885		2,262		
			T _{2B} ⁽⁹⁾ (Nm)		280	280				220	220	60	85	50		60		
	28	59.418	F _{2T} ⁽⁸⁾ (N)		10,771	10,771				8,415	8,415	3,029	4,207	2,020		2,188		
			T _{2B} ⁽⁹⁾ (Nm)		320	320				250	250	90	125	60		65		
	30	63.661	F _{2T} ⁽⁸⁾ (N)		10,681	10,681				8,325	8,325	3,613	4,555	2,199		2,199		
			T _{2B} ⁽⁹⁾ (Nm)		340	340				265	265	115	145	70		70		
	32	67.906	F _{2T} ⁽⁸⁾ (N)		10,750	10,750				8,394	8,394	4,123	4,418	2,356		2,209		
			T _{2B} ⁽⁹⁾ (Nm)		365	365				285	285	140	150	80		75		
36	76.394	F _{2T} ⁽⁸⁾ (N)		10,734	10,734				8,378	8,378	4,451	4,451	2,880		2,225			
		T _{2B} ⁽⁹⁾ (Nm)		410	410				320	320	170	170	110		85			
39	82.761	F _{2T} ⁽⁸⁾ (N)		10,874	10,874				8,337	8,337	4,471	4,471	2,779		2,175			
		T _{2B} ⁽⁹⁾ (Nm)		450	450				345	345	185	185	115		90			
40	84.883	F _{2T} ⁽⁸⁾ (N)		10,838	10,838				8,364	8,364	4,477	4,477	2,827		2,238			
		T _{2B} ⁽⁹⁾ (Nm)		460	460				355	355	190	190	120		95			
2.5	24	63.662	F _{2T} ⁽⁸⁾ (N)			16,022				13,195	13,195	3,927	5,184	2,827		5,027		
			T _{2B} ⁽⁹⁾ (Nm)			510				420	420	125	165	90		160		
3	20	63.662	F _{2T} ⁽⁸⁾ (N)		18,535	18,535			16,807	16,493	16,493	3,927	5,341	2,356		8,796		
			T _{2B} ⁽⁹⁾ (Nm)		590	590			535	525	525	125	170	75		280		
	22	70.028	F _{2T} ⁽⁸⁾ (N)		18,850	18,850			16,850	16,565	16,565	4,998	6,712	2,713		8,568		
			T _{2B} ⁽⁹⁾ (Nm)		660	660			590	580	580	175	235	95		300		
	25	79.578	F _{2T} ⁽⁸⁾ (N)		19,227	19,227			16,965	16,588	16,588	6,409	8,922	3,770		8,419		
			T _{2B} ⁽⁹⁾ (Nm)		765	765			675	660	660	255	355	150		335		
	28	89.127	F _{2T} ⁽⁸⁾ (N)		19,523	19,523			17,054	16,606	16,606	7,966	10,883	5,161		8,303		
			T _{2B} ⁽⁹⁾ (Nm)		870	870			760	740	740	355	485	230		370		
	32	101.859	F _{2T} ⁽⁸⁾ (N)		19,831	19,831			17,082	16,690	16,690	9,523	10,799	7,265		8,247		
			T _{2B} ⁽⁹⁾ (Nm)		1,010	1,010			870	850	850	485	550	370		420		

* The Maximal Driving Torque is also to be understood as the Maximal Acceleration Torque T_{2B}.
 The Emergency Stop Torque T_{2NOT} = 2 × T_{2B}, under the condition limited 1000 times in the whole service period.

(1) Number of Teeth (5) Working Pitch Circle Diameter (in mm) (8) Maximum Feed-Force (9) Maximum Driving Torque

Pinion with Helical Teeth (Interface : Keyway)

Table 6. The max. permitted torque and feed-force of pinion with Keyway

Pinion \ Rack			Quality	Q4	Q5H	Q5		Q5 ⁺	Q6	Q6M	Q6C	Q8H	Q8	Q9	Q10	
			Material	Carbon Steel	Alloy Steel		Carbon Steel	Carbon Steel	Carbon Steel	Carbon Steel	Carbon Steel	Carbon Steel	Q&T Alloy Steel	Carbon Steel	Stainless Steel	Carbon Steel
			Heat Treatment	Induction Hardening	Case Hardening	Carburized Induction	Induction Hardening	Induction Hardening	Induction Hardening	Induction Hardening	Induction Hardening	Normalizing	Quenched Tempered	Normalizing	Solution	Induction Hardening
Mn	z ⁽¹⁾	dw ⁽⁵⁾	Max. Torque * and Feed-Force													
4	15	63.662	F _{2T} ⁽⁸⁾ (N)		31,730		32,201	32,201	32,201	32,201	9,268	13,038	5,027		13,509	
			T _{2B} ⁽⁹⁾ (Nm)		1,010		1,025	1,025	1,025	1,025	295	415	160		430	
	18	76.394	F _{2T} ⁽⁸⁾ (N)		34,557		34,557	34,557	34,557	34,557	13,090	18,850	8,639		18,457	
			T _{2B} ⁽⁹⁾ (Nm)		1,320		1,320	1,320	1,320	1,320	500	720	330		705	
	20	84.883	F _{2T} ⁽⁸⁾ (N)		35,107		30,159	30,159	30,159	30,159	9,425	12,959	4,830		14,962	
			T _{2B} ⁽⁹⁾ (Nm)		1,490		1,280	1,280	1,280	1,280	400	550	205		635	
	21	89.127	F _{2T} ⁽⁸⁾ (N)		35,118		30,294	30,294	30,182	30,182	10,322	14,362	5,610		14,810	
			T _{2B} ⁽⁹⁾ (Nm)		1,565		1,350	1,350	1,345	1,345	460	640	250		660	
	22	93.371	F _{2T} ⁽⁸⁾ (N)		35,236		30,309	30,309	30,202	30,202	11,245	15,851	6,533		14,780	
			T _{2B} ⁽⁹⁾ (Nm)		1,645		1,415	1,415	1,410	1,410	525	740	305		690	
	24	101.859	F _{2T} ⁽⁸⁾ (N)		35,343		30,434	30,434	30,238	30,238	13,155	18,850	8,443		14,530	
			T _{2B} ⁽⁹⁾ (Nm)		1,800		1,550	1,550	1,540	1,540	670	960	430		740	
	25	106.103	F _{2T} ⁽⁸⁾ (N)		35,343		30,442	30,442	30,253	30,253	14,137	19,321	9,425		14,514	
			T _{2B} ⁽⁹⁾ (Nm)		1,875		1,615	1,615	1,605	1,605	750	1,025	500		770	
5	18	95.493	F _{2T} ⁽⁸⁾ (N)	54,140	54,140		54,140	54,140	54,035	54,035			18,012		35,081	
			T _{2B} ⁽⁹⁾ (Nm)	2,585	2,585		2,585	2,585	2,580	2,580			860		1,575	
	24	127.324	F _{2T} ⁽⁸⁾ (N)	48,538	56,470		48,538	48,538	48,538	48,538			18,064		28,588	
			T _{2B} ⁽⁹⁾ (Nm)	3,090	3,595		3,090	3,090	3,090	3,090			1,150		1,820	
6	20	127.324	F _{2T} ⁽⁸⁾ (N)	69,036	79,011		69,036	69,036	69,036	69,036			21,756		47,359	
			T _{2B} ⁽⁹⁾ (Nm)	4,395	5,030		4,395	4,395	4,395	4,395			1,385		3,015	
	25	159.155	F _{2T} ⁽⁸⁾ (N)	72,131	82,058		72,131	72,131	72,068	72,068			33,552		49,574	
			T _{2B} ⁽⁹⁾ (Nm)	5,740	6,530		5,740	5,740	5,735	5,735			2,670		3,945	
8	18	152.789	F _{2T} ⁽⁸⁾ (N)	134,368	134,368		134,368		134,368	134,368			62,832		99,876	
			T _{2B} ⁽⁹⁾ (Nm)	10,265	10,265		10,265		10,265	10,265			4,800		7,630	
	20	169.766	F _{2T} ⁽⁸⁾ (N)	126,527	136,188		126,527		126,527	126,527			46,122		93,423	
			T _{2B} ⁽⁹⁾ (Nm)	10,740	11,560		10,740		10,740	10,740			3,915		7,930	
10	20	212.207	F _{2T} ⁽⁸⁾ (N)	193,490	190,899		193,490		193,443	193,443			85,812		143,492	
			T _{2B} ⁽⁹⁾ (Nm)	20,530	20,255		20,530		20,525	20,525			9,105		15,225	

* The Maximal Driving Torque is also to be understood as the Maximal Acceleration Torque T_{2B}.

The Emergency Stop Torque T_{2NOT} = 2 x T_{2B}, under the condition limited 1000 times in the whole service period.

(1) Number of Teeth (5) Working Pitch Circle Diameter (in mm) (8) Maximum Feed-Force (9) Maximum Driving Torque

Pinion with Helical Teeth

(Interface : Long Shaft Pinion with Keyway for Hollow-Shaft)

Quality DIN 5

Tooth Thickness Tolerance : e25

Left-Hand Helical Teeth

Case-Hardened and Teeth Ground

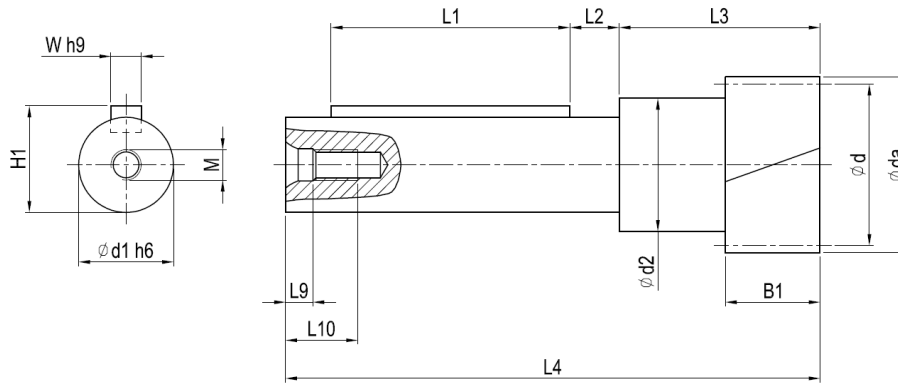

Mn.	z ⁽¹⁾	x ⁽²⁾	da ⁽³⁾	d ⁽⁴⁾	dw ⁽⁵⁾	d1 h ₆	d2	B1	L1	L2	L3	L4	M	L9	L10	W h9	H1	L ⁽⁶⁾	Order Code
1.5	20	0	34.831	31.831	31.831	20	26	20	40	7.5	45	100	M5	4.8	12.5	6	22.5	100	G1JL20D20
2	15	0.417	37.5	31.831	33.5	20	24	25	28	13.5	50	105	M5	4.8	12.5	6	22.5	100	G02L15D20
	20	0	46.441	42.441	42.441	25	35	25	63	13	53	141	M8	7.2	19	8	28	133.332	G02L20D25
	30	0	67.662	63.662	63.662	25	38	25	63	13	53	141	M8	7.2	19	8	28	200	G02L30D25
	30	0	67.662	63.662	63.662	28	42	25	80	14.5	57.5	166	M8	7.2	19	8	31	200	G02L30D28
	30	0	67.662	63.662	63.662	36	48	25	100	12.5	57	181	M12	10	28	10	39	200	G02L30D36
3	20	0	69.662	63.662	63.662	25	38	30	63	13	55	143	M8	7.2	19	8	28	200	G03L20D25
	20	0	69.662	63.662	63.662	28	42	30	80	14.5	60	168	M8	7.2	19	8	31	200	G03L20D28
	20	0	69.662	63.662	63.662	36	48	30	100	12.5	62	186	M12	10	28	10	39	200	G03L20D36
4	15	0	71.662	63.662	63.662	28	42	40	80	14.5	65	173	M8	7.2	19	8	31	200	G04L15D28
	15	0	71.662	63.662	63.662	36	48	40	100	12.5	67	191	M12	10	28	10	39	200	G04L15D36
	15	0	71.662	63.662	63.662	48	57	40	125	9	72	216	M12	10	28	14	51.5	200	G04L15D48
	30	0	135.325	127.324	127.324	48	57	40	125	9	72	216	M12	10	28	14	51.5	400	G04L30D48
5	12	0.434	78.002	63.662	68	48	57	50	125	9	82	226	M12	10	28	14	51.5	200	G05L12D48
	15	0.5	94.578	79.578	84.578	60	68	50	150	10	90	272	M16	12	36	18	64	250	G05L15D60
6	13	0.5	100.761	82.761	88.761	60	70	60	150	10	100	282	M16	12	36	18	64	260	G06L13D60

(1) Number of teeth (2) Profile modification factor (3) Diameter of addendum circle (4) Pitch circle diameter
 (5) Working pitch circle diameter (6) Pitch circle length $L = \pi \times d$

Pinion with Helical Teeth

(Interface : Long Shaft Pinion with Keyway for Hollow-Shaft)

Quality DIN 5

Tooth Thickness Tolerance : e25

Left-Hand Helical Teeth

Case-Hardened and Teeth Ground

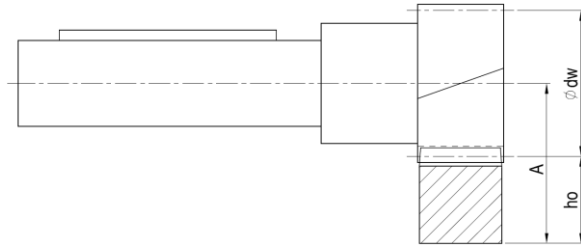
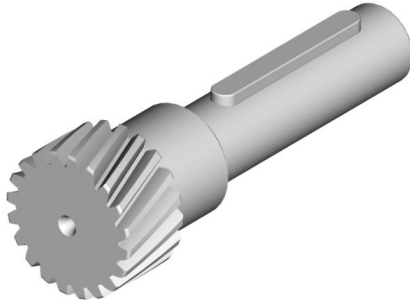

$$A = h_o + \frac{\phi \, dw}{2}$$

In table 7, the maximum permissible torque of pinion with Long Shaft w. KW for APEX AF-/PII-Gearbox, and the rack is calculated on the basis of a speed of 1.5 m/s and providing good lubrication (using an automatic lubrication system or manually applied grease every day), the tooth root strength factor $S_F \geq 1.4$, tooth surface strength coefficient $S_H \geq 1$, the safety factor $S_B \cong 1$, and the required service life of 20,000 hours. By higher speed, the max. permissible torque reduced. The user needs to increase the safety factor for the application.

Backlash changes by different center height. Please contact APEX under WWW.APEXDYNA.COM.

Table 7, the max. permitted torque and feed-force of pinion with Long Shaft w. KW for APEX AF- / PII-Series

Pinion \ Rack			Quality	Q4	Q5H	Q5		Q5 ⁺	Q6	Q6M	Q6C	Q8H	Q8	Q9	Q10	
			Material	Carbon Steel	Alloy Steel		Carbon Steel	Carbon Steel	Carbon Steel	Carbon Steel	Carbon Steel	Carbon Steel	Q&T Alloy Steel	Carbon Steel	Stainless Steel	Carbon Steel
			Heat Treatment	Induction Hardening	Case Hardening	Carburized Induction	Induction Hardening	Induction Hardening	Induction Hardening	Induction Hardening	Induction Hardening	Normalizing	Quenched Tempered	Normalizing	Solution	Induction Hardening
Mn	z ⁽¹⁾	dw ⁽⁵⁾	Max. Torque * and Feed-Force													
1.5	20	31.83	$F_{2T}^{(8)}$ (N)						5,027		942		628		1,257	
			$T_{2B}^{(9)}$ (Nm)						80		15		10		20	
2	15	33.50	$F_{2T}^{(8)}$ (N)		9,111	9,111			8,168	8,168	1,571	1885	1,257		2,199	
			$T_{2B}^{(9)}$ (Nm)		145	145			130	130	25	30	20		35	
	20	42.44	$F_{2T}^{(8)}$ (N)		10,367	10,367			8,247	8,247	1,649	2,121	1,414		2,356	
			$T_{2B}^{(9)}$ (Nm)		220	220			175	175	35	45	30		50	
30	63.66	$F_{2T}^{(8)}$ (N)		10,681	10,681			8,325	8,325	3,613	4,555	2,199		2,199		
		$T_{2B}^{(9)}$ (Nm)		340	340			265	265	115	145	70		70		
3	20	63.66	$F_{2T}^{(8)}$ (N)		18,535	18,535		16,807	16,493	16,493	3,927	5,341	2,356		8,796	
			$T_{2B}^{(9)}$ (Nm)		590	590		535	525	525	125	170	75		280	
4	15	63.66	$F_{2T}^{(8)}$ (N)		31,730		32,201	32,201	32,201	32,201	9,268	13,038	5,027		13,509	
			$T_{2B}^{(9)}$ (Nm)		1,010		1,025	1,025	1,025	1,025	295	415	160		430	
	30	127.32	$F_{2T}^{(8)}$ (N)		35,421		30,473	30,473	30,159	30,159	16,258	19,007	11,310		13,666	
			$T_{2B}^{(9)}$ (Nm)		2,255		1,940	1,940	1,920	1,920	1,035	1,210	720		870	
5	12	68.00	$F_{2T}^{(8)}$ (N)	28,117	28,117		28,117	28,117	27,018	27,018			4,241		5,027	
			$T_{2B}^{(9)}$ (Nm)	895	895		895	895	860	860			135		160	
	15	84.58	$F_{2T}^{(8)}$ (N)	34,809	34,809		34,809	34,809	34,557	34,557			6,911		10,933	
			$T_{2B}^{(9)}$ (Nm)	1,385	1,385		1,385	1,385	1,375	1,375			275		435	
6	13	88.76	$F_{2T}^{(8)}$ (N)	38,907	38,907		38,907	38,907	38,182	38,182			9,425		10,875	
			$T_{2B}^{(9)}$ (Nm)	1,610	1,610		1,610	1,610	1,580	1,580			390		450	

* The Maximal Driving Torque is also to be understood as the Maximal Acceleration Torque T_{2B} .

The Emergency Stop Torque $T_{2NOT} = 2 \times T_{2B}$, under the condition limited 1000 times in the whole service period.

(1) Number of Teeth (5) Working Pitch Circle Diameter (in mm) (8) Maximum Feed-Force (9) Maximum Driving Torque

Pinion with Helical Teeth

(Interface : Long Shaft Pinion without Keyway for Hollow-Shaft)

Quality DIN 5

Tooth Thickness Tolerance : e25

Left-Hand Helical Teeth

Case-Hardened and Teeth Ground

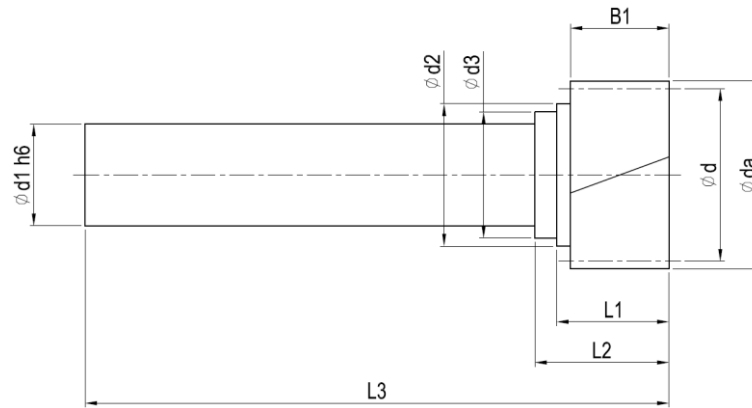

Mn.	z ⁽¹⁾	x ⁽²⁾	d _a ⁽³⁾	d ⁽⁴⁾	d _w ⁽⁵⁾	d ₁ h ₆	d ₂	d ₃	B ₁	L ₁	L ₂	L ₃	L ⁽⁶⁾	Order Code
1.5	20	0	34.831	31.831	31.831	20	26	-	20	26	-	100.25	100	H1JL20D20
2	15	0.4172	37.5	31.831	33.5	20	24	-	25	31	-	105	100	H02L15D20
	20	0	46.441	42.441	42.441	25	35	31	25	28.5	34	148	133.332	H02L20D25
	30	0	67.662	63.662	63.662	25	38	31	25	28.5	34	148	200	H02L30D25
	30	0	67.662	63.662	63.662	28	42	36	25	33	38.5	180	200	H02L30D28
	30	0	67.662	63.662	63.662	36	48	-	25	32.5	-	203	200	H02L30D36
3	20	0	69.662	63.662	63.662	25	31	-	30	36.5	-	150	200	H03L20D25
	20	0	69.662	63.662	63.662	28	42	36	30	35.5	41	183	200	H03L20D28
	20	0	69.662	63.662	63.662	36	48	-	30	37.5	-	208	200	H03L20D36
4	15	0	71.662	63.662	63.662	28	36	-	40	46	-	188	200	H04L15D28
	15	0	71.662	63.662	63.662	36	48	-	40	42.5	-	213	200	H04L15D36
	15	0	71.662	63.662	63.662	48	57	-	40	43.5	-	240	200	H04L15D48
	30	0	135.325	127.324	127.324	48	57	-	40	43.5	-	240	400	H04L30D48
5	12	0.434	78.002	63.662	68	48	57	-	50	53.5	-	250	200	H05L12D48
	15	0.5	94.578	79.578	84.578	60	70	-	50	55	-	275	250	H05L15D60
6	13	0.5	100.761	82.761	88.761	48	57	-	60	63.5	-	260	260	H06L13D48
	13	0.5	100.761	82.761	88.761	60	70	-	60	65	-	285	260	H06L13D60
	15	0.5	113.493	95.493	101.493	60	70	-	60	65	-	285	300	H06L15D60

- (1) Number of teeth (2) Profile modification factor (3) Diameter of addendum circle (4) Pitch circle diameter
 (5) Working pitch circle diameter (6) Pitch circle length $L = \pi \times d$

Pinion with Helical Teeth

(Interface : Long Shaft Pinion without Keyway for Hollow-Shaft)

Quality DIN 5
Tooth Thickness Tolerance : e25
Left-Hand Helical Teeth
Case-Hardened and Teeth Ground

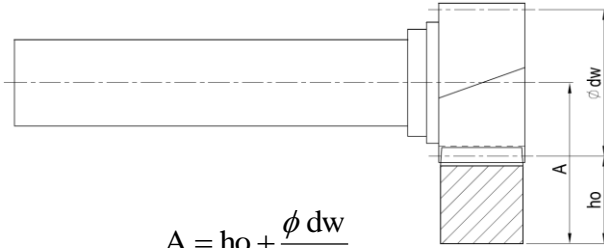
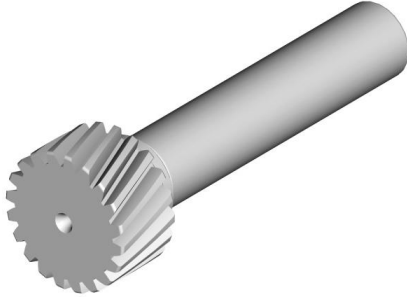

$$A = h_o + \frac{\phi dw}{2}$$

In table 8, the maximum permissible torque of pinion with Long Shaft w/o KW for APEX AF-/ PII - Gearbox, and the rack is calculated on the basis of a speed of 1.5 m/s and providing good lubrication (using an automatic lubrication system or manually applied grease every day), the tooth root strength factor $S_F \geq 1.4$, tooth surface strength coefficient $S_H \geq 1$, the safety factor $S_B = 1$, and the required service life of 20,000 hours. By higher speed, the max. permissible torque reduced. The user needs to increase the safety factor for the application. Backlash changes by different center height. Please contact APEX under WWW.APEXDYNA.COM.

Table 8, the max. permitted torque and feed-force of pinion with Long Shaft w/o KW for APEX AF-/ PII-Series

Pinion			Rack												
			Quality	Q4	Q5H	Q5		Q5+	Q6	Q6M	Q6C	Q8H	Q8	Q9	Q10
			Material	Carbon Steel	Alloy Steel		Carbon Steel	Carbon Steel	Carbon Steel	Carbon Steel	Carbon Steel	Carbon Steel	Q&T Alloy Steel	Carbon Steel	Stainless Steel
			Heat Treatment	Induction Hardening	Case Hardening	Carburized Induction	Induction Hardening	Induction Hardening	Induction Hardening	Induction Hardening	Normalizing	Quenched Tempered	Normalizing	Solution	Induction Hardening
Mn	z ⁽¹⁾	dw ⁽⁵⁾	Max. Torque * and Feed-Force												
1.5	20	31.83	F _{2T} ⁽⁸⁾ (N)						5,027		942		628		1,257
			T _{2B} ⁽⁹⁾ (Nm)						80		15		10		20
2	15	33.50	F _{2T} ⁽⁸⁾ (N)		9,111	9,111			8,168	8,168	1,571	1885	1,257		2,199
			T _{2B} ⁽⁹⁾ (Nm)		145	145			130	130	25	30	20		35
	20	42.44	F _{2T} ⁽⁸⁾ (N)		10,367	10,367			8,247	8,247	1,649	2,121	1,414		2,356
			T _{2B} ⁽⁹⁾ (Nm)		220	220			175	175	35	45	30		50
30	63.66	F _{2T} ⁽⁸⁾ (N)		10,681	10,681			8,325	8,325	3,613	4,555	2,199		2,199	
		T _{2B} ⁽⁹⁾ (Nm)		340	340			265	265	115	145	70		70	
3	20	63.66	F _{2T} ⁽⁸⁾ (N)		18,535	18,535		16,807	16,493	16,493	3,927	5,341	2,356		8,796
			T _{2B} ⁽⁹⁾ (Nm)		590	590		535	525	525	125	170	75		280
4	15	63.66	F _{2T} ⁽⁸⁾ (N)		31,730	31,730		32,201	32,201	32,201	9,268	13,038	5,027		13,509
			T _{2B} ⁽⁹⁾ (Nm)		1,010	1,010		1,025	1,025	1,025	295	415	160		430
	30	127.3 2	F _{2T} ⁽⁸⁾ (N)		35,421	35,421		30,473	30,159	30,159	16,258	19,007	11,310		13,666
			T _{2B} ⁽⁹⁾ (Nm)		2,255	2,255		1,940	1,920	1,920	1,035	1,210	720		870
5	12	68.00	F _{2T} ⁽⁸⁾ (N)	28,117	28,117		28,117	28,117	27,018	27,018			4,241		5,027
			T _{2B} ⁽⁹⁾ (Nm)	895	895		895	895	860	860			135		160
	15	84.58	F _{2T} ⁽⁸⁾ (N)	34,809	34,809		34,809	34,809	34,557	34,557			6,911		10,933
			T _{2B} ⁽⁹⁾ (Nm)	1,385	1,385		1,385	1,385	1,375	1,375			275		435
6	13	88.76	F _{2T} ⁽⁸⁾ (N)	38,907	38,907		38,907	38,907	38,182	38,182			9,425		10,875
			T _{2B} ⁽⁹⁾ (Nm)	1,610	1,610		1,610	1,610	1,580	1,580			390		450
	15	101.4 9	F _{2T} ⁽⁸⁾ (N)	45,971	45,971		45,971	45,971	45,867	45,867			13,823		17,698
			T _{2B} ⁽⁹⁾ (Nm)	2,195	2,195		2,195	2,195	2,190	2,190			660		845

* The Maximal Driving Torque is also to be understood as the Maximal Acceleration Torque T_{2B}.

The Emergency Stop Torque T_{2NOT} = 2 x T_{2B}, under the condition limited 1000 times in the whole service period.

(1) Number of Teeth (5) Working Pitch Circle Diameter (in mm) (8) Maximum Feed-Force (9) Maximum Driving Torque

Rack with Straight Teeth

Quality 4 / Carbon Steel
 Tooth Thickness Tolerance : $-13 \sim 0 \mu\text{m}$
 Straight Teeth
 Teeth Induction Hardened and Ground
 All Sides Ground

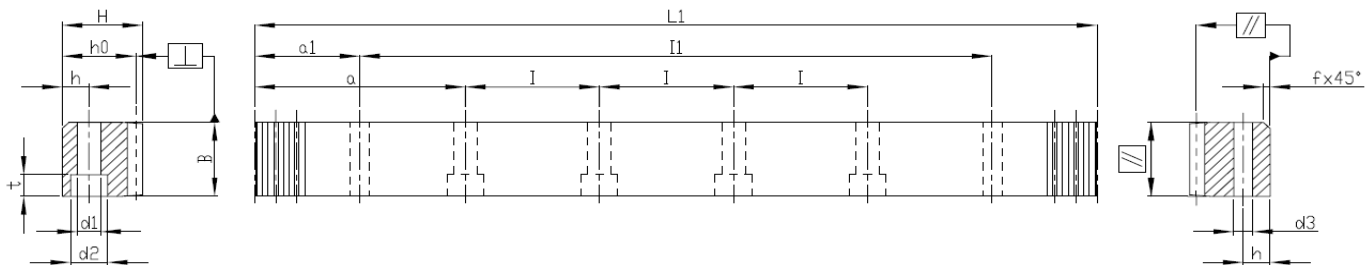

Mn	Pt ⁽¹⁾	L1	Teeth No.	B	H	h ₀	f	a	I	Hole No.	h	d1	d2	t	a1	II	d3	f _p ⁽²⁾	F _p ⁽³⁾	Order Code *
5	15.70796	1005.31	64	49	39	34	3	62.83	125.66	8	12	14	20	13	30.10	945.11	11.7	0.005	0.02	05041100C10
6	18.84956	1017.88	54	59	49	43	3	63.62	127.23	8	16	18	26	17	31.40	955.08	15.7	0.005	0.02	06041100C10
8	25.13274	1005.31	40	79	79	71	3	62.83	125.66	8	25	22	33	21	26.60	952.11	19.7	0.006	0.022	08041100C10
10	31.41593	1005.31	32	99	99	89	3	62.83	125.66	8	32	33	48	32	125.66	753.99	19.7	0.006	0.022	10041100C10
12	37.69911	1017.88	27	120	120	108	3	63.62	127.23	8	40	39	58	38	127.23	763.42	19.7	0.007	0.023	12041100C10

(1) Teeth Pitch $P_t = \text{Module} \times \pi$ (2) $f_p = \text{Single Pitch Error}$ (3) $F_p = \text{Total Pitch Error}$

* For all models APEX also provides Rack without screw-holes. By ordering please change the 2nd last order-code position from "1" to "0". Please also refer to page 14.

Quality 5H / Alloy Steel
 Tooth Thickness Tolerance : -15 ~ 0 μm
 Straight Teeth
 Material Case-Hardened
 Teeth Ground and all Sides Ground

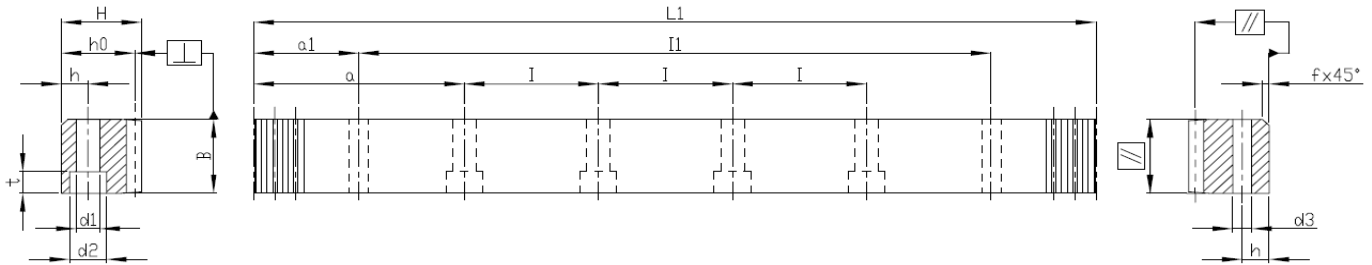

Mn	Pt ⁽¹⁾	LI	Teeth No.	B	H	ho	f	a	I	Hole No.	h	d1	d2	t	a1	II	d3	f _p ⁽²⁾	F _p ⁽³⁾	Order Code *
2	6.28319	1005.31	160	24	24	22	2	62.83	125.66	8	9	10	15	9	31.30	942.70	7.7	0.006	0.024	025H1100M10
3	9.42478	1017.88	108	29	29	26	2	63.62	127.23	8	10	12	17.5	11	28.60	960.60	11.7	0.006	0.026	035H1100M10
4	12.56637	1005.31	80	39	39	35	3	62.83	125.66	8	13	16	23	15	30.30	944.70	15.7	0.007	0.028	045H1100M10
5	15.70796	1005.31	64	49	49	44	3	62.83	125.66	8	15	18	26	17	34.80	935.70	15.7	0.007	0.028	055H1100M10
6	18.84956	1017.88	54	59	59	53	3	63.62	127.23	8	20	22	33	21	98.60	820.60	19.7	0.007	0.028	065H1100M10
8	25.13274	1005.31	40	79	79	71	3	62.83	125.66	8	25	26	39	25	26.60	952.11	19.7	0.008	0.031	085H1100M10
10	31.41593	1005.31	32	99	99	89	3	62.83	125.66	8	32	39	58	38	125.66	753.99	19.7	0.008	0.031	105H1100M10

(1) Teeth Pitch Pt = Module $\times \pi$ (2) fp = Single Pitch Error (3) Fp = Total Pitch Error

* For all models APEX also provides Rack without screw-holes. By ordering please change the 2nd last order-code position from "1" to "0". Please also refer to page 14.

Especially for the application without back-support.

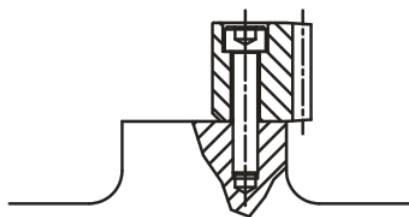

Without alignment / back-support

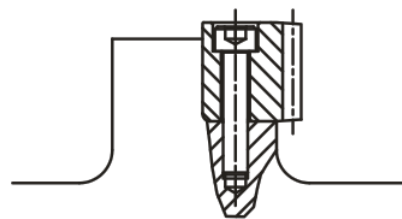

With alignment / back-support

Rack with Straight Teeth

Quality 5 / Alloy Steel
 Tooth Thickness Tolerance : $-15 \sim 0 \mu\text{m}$
 Straight Teeth
 Material Carburized, Induction Hardened
 Teeth Ground and all Sides Ground

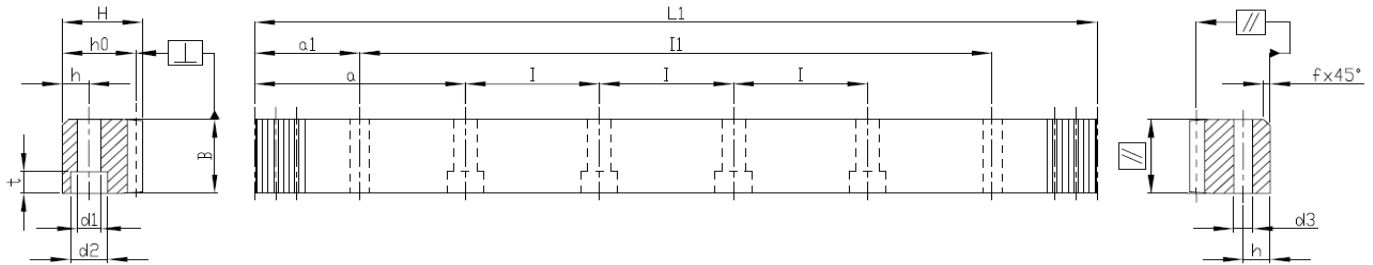

Mn	Pt ⁽¹⁾	L1	Teeth No.	B	H	h ₀	f	a	I	Hole No.	h	d1	D2	T	a1	II	d3	f _p ⁽²⁾	F _p ⁽³⁾	Order Code*
2	6.28319	251.33	40	24	24	22	2	62.83	125.66	2	8	7	11	7	31.3	188.73	5.7	0.005	0.018	02051025M10
2	6.28319	502.66	80	24	24	22	2	62.83	125.66	4	8	7	11	7	31.3	440.06	5.7	0.006	0.021	02051050M10
2	6.28319	1005.31	160	24	24	22	2	62.83	125.66	8	8	7	11	7	31.3	942.71	5.7	0.006	0.024	02051100M10
3	9.42478	254.47	27	29	29	26	2	63.62	127.23	2	9	10	15	9	34.4	185.67	7.7	0.006	0.019	03051025M10
3	9.42478	508.94	54	29	29	26	2	63.62	127.23	4	9	10	15	9	34.4	440.14	7.7	0.006	0.023	03051050M10
3	9.42478	1017.88	108	29	29	26	2	63.62	127.23	8	9	10	15	9	34.4	949.08	7.7	0.006	0.026	03051100M10

(1) Teeth Pitch $P_t = \text{Module} \times \pi$ (2) $f_p = \text{Single Pitch Error}$ (3) $F_p = \text{Total Pitch Error}$

* For all models APEX also provides Rack without screw-holes. By ordering please change the 2nd last order-code position from "1" to "0". Please also refer to page 14.

Quality 5 / Carbon Steel
 Tooth Thickness Tolerance : -15 ~ 0 μm
 Straight Teeth
 Teeth Induction Hardened and Ground
 All Sides Ground

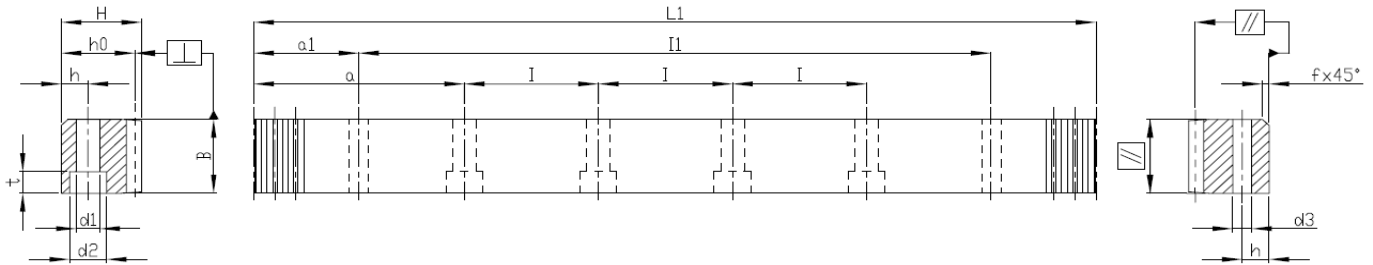

Mn	Pt ⁽¹⁾	L1	Teeth No.	B	H	ho	f	a	l	Hole No.	h	d1	d2	t	a1	l1	d3	f _p ⁽²⁾	F _p ⁽³⁾	Order Code*
4	12.56637	251.33	20	39	39	35	3	62.83	125.66	2	12	10	15	9	37.5	176.33	7.7	0.006	0.021	04051025C10
4	12.56637	502.66	40	39	39	35	3	62.83	125.66	4	12	10	15	9	37.5	427.66	7.7	0.007	0.026	04051050C10
4	12.56637	1005.31	80	39	39	35	3	62.83	125.66	8	12	10	15	9	37.5	930.31	7.7	0.007	0.028	04051100C10
4	12.56637	1005.31	80	39	39	35	3	62.83	125.66	8	12	14	20	13	37.5	930.31	11.7	0.007	0.028	04051100CS0
4	12.56637	1256.64	100	39	39	35	3	62.83	125.66	10	12	10	15	9	37.5	1181.64	7.7	0.007	0.028	04051125C10
4	12.56637	1507.96	120	39	39	35	3	62.83	125.66	12	12	10	15	9	37.5	1432.96	7.7	0.007	0.028	04051150C10
4	12.56637	1507.96	120	39	39	35	3	62.83	125.66	12	12	14	20	13	37.5	1432.96	11.7	0.007	0.028	04051150CS0
4	12.56637	1759.29	140	39	39	35	3	62.83	125.66	14	12	10	15	9	37.5	1684.29	7.7	0.007	0.028	04051175C10
4	12.56637	2010.62	160	39	39	35	3	62.83	125.66	16	12	10	15	9	37.5	1935.62	7.7	0.008	0.032	04051200C10
4	12.56637	2010.62	160	39	39	35	3	62.83	125.66	16	12	14	20	13	37.5	1935.62	11.7	0.008	0.032	04051200CS0
5	15.70796	1005.31	64	49	39	34	3	62.83	125.66	8	12	14	20	13	30.1	945.11	11.7	0.007	0.028	05051100C10
6	18.84956	1017.88	54	59	49	43	3	63.62	127.23	8	16	18	26	17	31.4	955.08	15.7	0.007	0.028	06051100C10
8	25.13274	1005.31	40	79	79	71	3	62.83	125.66	8	25	22	33	21	26.6	952.11	19.7	0.008	0.031	08051100C10
10	31.41593	1005.31	32	99	99	89	3	62.83	125.66	8	32	33	48	32	125.66	753.99	19.7	0.008	0.031	10051100C10
12	37.69911	1017.88	27	120	120	108	3	63.62	127.23	8	40	39	58	38	127.23	763.42	19.7	0.01	0.033	12051100C10

(1) Teeth Pitch Pt = Module $\times \pi$ (2) f_p = Single Pitch Error (3) F_p = Total Pitch Error

* For all models APEX also provides Rack without screw-holes. By ordering please change the 2nd last order-code position from "I" to "0". Please also refer to page 14.

Rack with Straight Teeth

Quality 6 / Carbon Steel
 Tooth Thickness Tolerance : -22 ~ 0 μm
 Straight Teeth
 Teeth Induction Hardened and Ground
 All Sides Ground

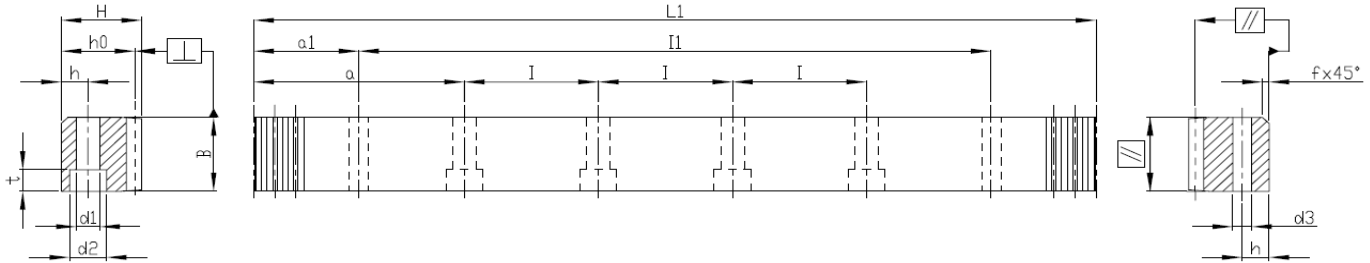

Mn	Pt ⁽¹⁾	L1	Teeth No.	B	H	h ₀	f	a	l	Hole No.	h	d1	d2	t	a1	l1	d3	f _p ⁽²⁾	F _p ⁽³⁾	Order Code*
1	3.14159	502.66	160	15	15	14	2	62.85	125.66	4	6	5	8	5	31.3	440.05	5.7	0.008	0.029	01061050C10
1	3.14159	1005.31	320	15	15	14	2	62.85	125.66	8	6	5	8	5	31.3	942.71	5.7	0.008	0.033	01061100C10
1	3.14159	1507.96	480	15	15	14	2	62.85	125.66	12	6	5	8	5	31.3	1445.36	5.7	0.008	0.033	01061150C10
2	6.28319	502.66	80	24	24	22	2	62.83	125.66	4	8	7	11	7	31.3	440.06	5.7	0.008	0.029	02061050C10
2	6.28319	1005.31	160	24	24	22	2	62.83	125.66	8	8	7	11	7	31.3	942.71	5.7	0.008	0.034	02061100C10
2	6.28319	1256.64	200	24	24	22	2	62.83	125.66	10	8	7	11	7	31.3	1194.04	5.7	0.008	0.034	02061125C10
2	6.28319	1507.96	240	24	24	22	2	62.83	125.66	12	8	7	11	7	31.3	1445.36	5.7	0.008	0.034	02061150C10
2	6.28319	1759.29	280	24	24	22	2	62.83	125.66	14	8	7	11	7	31.3	1696.69	5.7	0.008	0.034	02061175C10
2	6.28319	2010.62	320	24	24	22	2	62.83	125.66	16	8	7	11	7	31.3	1948.02	5.7	0.009	0.038	02061200C10
3	9.42478	508.94	54	29	29	26	2	63.62	127.23	4	9	10	15	9	34.4	440.14	7.7	0.008	0.032	03061050C10
3	9.42478	1017.88	108	29	29	26	2	63.62	127.23	8	9	10	15	9	34.4	949.08	7.7	0.009	0.037	03061100C10
3	9.42478	1272.35	135	29	29	26	2	63.62	127.23	10	9	10	15	9	34.4	1203.55	7.7	0.009	0.037	03061125C10
3	9.42478	1526.81	162	29	29	26	2	63.62	127.23	12	9	10	15	9	34.4	1458.01	7.7	0.009	0.037	03061150C10
3	9.42478	1781.28	189	29	29	26	2	63.62	127.23	14	9	10	15	9	34.4	1712.48	7.7	0.009	0.037	03061175C10
3	9.42478	2035.75	216	29	29	26	2	63.62	127.23	16	9	10	15	9	34.4	1966.952	7.7	0.01	0.042	03061200C10
4	12.56637	502.66	40	39	39	35	3	62.83	125.66	4	12	10	15	9	37.5	427.66	7.7	0.009	0.034	04061050C10
4	12.56637	502.66	40	39	39	35	3	62.83	125.66	4	12	14	20	13	37.5	427.66	11.7	0.009	0.034	04061050CS0
4	12.56637	1005.31	80	39	39	35	3	62.83	125.66	8	12	10	15	9	37.5	930.31	7.7	0.01	0.04	04061100C10
4	12.56637	1005.31	80	39	39	35	3	62.83	125.66	8	12	14	20	13	37.5	930.31	11.7	0.01	0.04	04061100CS0
4	12.56637	1256.64	100	39	39	35	3	62.83	125.66	10	12	10	15	9	37.5	1181.64	7.7	0.01	0.04	04061125C10
4	12.56637	1507.96	120	39	39	35	3	62.83	125.66	12	12	10	15	9	37.5	1432.96	7.7	0.01	0.04	04061150C10
4	12.56637	1507.96	120	39	39	35	3	62.83	125.66	12	12	14	20	13	37.5	1432.96	11.7	0.01	0.04	04061150CS0
4	12.56637	1759.29	140	39	39	35	3	62.83	125.66	14	12	10	15	9	37.5	1684.29	7.7	0.01	0.04	04061175C10
4	12.56637	2010.62	160	39	39	35	3	62.83	125.66	16	12	10	15	9	37.5	1935.62	7.7	0.011	0.045	04061200C10
4	12.56637	2010.62	160	39	39	35	3	62.83	125.66	16	12	14	20	13	37.5	1935.62	11.7	0.011	0.045	04061200CS0

(1) Teeth Pitch $P_t = \text{Module} \times \pi$ (2) $f_p = \text{Single Pitch Error}$ (3) $F_p = \text{Total Pitch Error}$

* For all models APEX also provides Rack without screw-holes. By ordering please change the 2nd last order-code position from "1" to "0". Please also refer to page 14.

Quality 6 / Carbon Steel
 Tooth Thickness Tolerance : -22 ~ 0 μm
 Straight Teeth
 Teeth Induction Hardened and Ground
 All Sides Ground

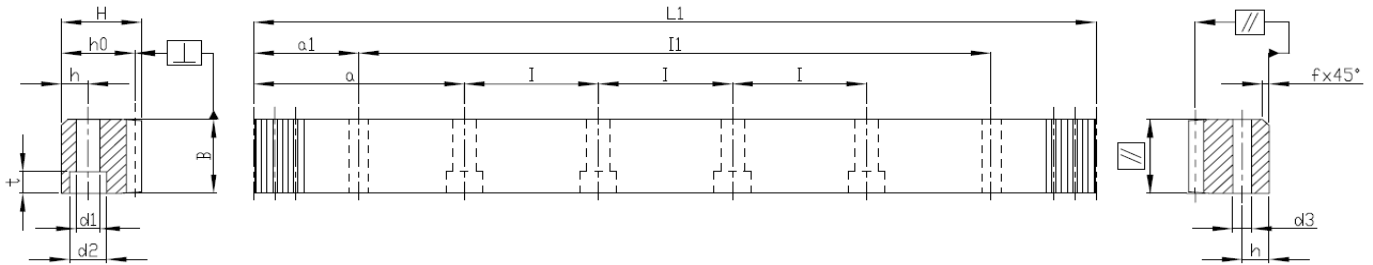

Mn	Pt ⁽¹⁾	L1	Teeth No.	B	H	ho	f	a	l	Hole No.	h	d1	d2	t	a1	l1	d3	f _p ⁽²⁾	F _p ⁽³⁾	Order Code*
5	15.70796	502.66	32	49	39	34	3	62.83	125.66	4	12	14	20	13	30.1	442.46	11.7	0.009	0.034	05061050C10
5	15.70796	1005.31	64	49	39	34	3	62.83	125.66	8	12	14	20	13	30.1	945.11	11.7	0.01	0.04	05061100C10
5	15.70796	1256.64	80	49	39	34	3	62.83	125.66	10	12	14	20	13	30.1	1196.44	11.7	0.01	0.04	05061125C10
5	15.70796	1507.96	96	49	39	34	3	62.83	125.66	12	12	14	20	13	30.1	1447.76	11.7	0.01	0.04	05061150C10
5	15.70796	1759.29	112	49	39	34	3	62.83	125.66	14	12	14	20	13	30.1	1699.09	11.7	0.01	0.04	05061175C10
5	15.70796	2010.62	128	49	39	34	3	62.83	125.66	16	12	14	20	13	30.1	1950.42	11.7	0.011	0.045	05061200C10
6	18.84956	508.94	27	59	49	43	3	63.62	127.23	4	16	18	26	17	31.4	446.14	15.7	0.009	0.034	06061050C10
6	18.84956	1017.88	54	59	49	43	3	63.62	127.23	8	16	18	26	17	31.4	955.08	15.7	0.01	0.04	06061100C10
6	18.84956	1281.77	68	59	49	43	3	63.62	127.23	10	16	18	26	17	31.4	1218.97	15.7	0.01	0.04	06061125C10
6	18.84956	1526.81	81	59	49	43	3	63.62	127.23	12	16	18	26	17	31.4	1464.01	15.7	0.01	0.04	06061150C10
6	18.84956	1790.71	95	59	49	43	3	63.62	127.23	14	16	18	26	17	31.4	1727.91	15.7	0.01	0.04	06061175C10
6	18.84956	2035.75	108	59	49	43	3	63.62	127.23	16	16	18	26	17	31.4	1972.95	15.7	0.011	0.045	06061200C10
8	25.13274	502.66	20	79	79	71	3	62.83	125.66	4	25	22	33	21	26.6	449.46	19.7	0.011	0.037	08061050C10
8	25.13274	1005.31	40	79	79	71	3	62.83	125.66	8	25	22	33	21	26.6	952.11	19.7	0.011	0.043	08061100C10
8	25.13274	1256.64	50	79	79	71	3	62.83	125.66	10	25	22	33	21	26.6	1203.44	19.7	0.011	0.043	08061125C10
8	25.13274	1507.96	60	79	79	71	3	62.83	125.66	12	25	22	33	21	26.6	1454.76	19.7	0.011	0.043	08061150C10
8	25.13274	1759.29	70	79	79	71	3	62.83	125.66	14	25	22	33	21	26.6	1706.09	19.7	0.011	0.043	08061175C10
8	25.13274	2010.62	80	79	79	71	3	62.83	125.66	16	25	22	33	21	26.6	1957.42	19.7	0.012	0.048	08061200C10
10	31.41593	1005.31	32	99	99	89	3	62.83	125.66	8	32	33	48	32	125.66	753.99	19.7	0.011	0.043	10061100C10
12	37.69911	1017.88	27	120	120	108	3	63.62	127.23	8	40	39	58	38	127.23	763.42	19.7	0.013	0.046	12061100C10

(1) Teeth Pitch Pt = Module $\times \pi$ (2) f_p = Single Pitch Error (3) F_p = Total Pitch Error

* For all models APEX also provides Rack without screw-holes. By ordering please change the 2nd last order-code position from "1" to "0". Please also refer to page 14.

Rack with Straight Teeth

Quality 6M / Carbon Steel
 Tooth Thickness Tolerance : -22 ~ 0 μm
 Straight Teeth
 Teeth Induction Hardened and Ground
 All Sides Milled

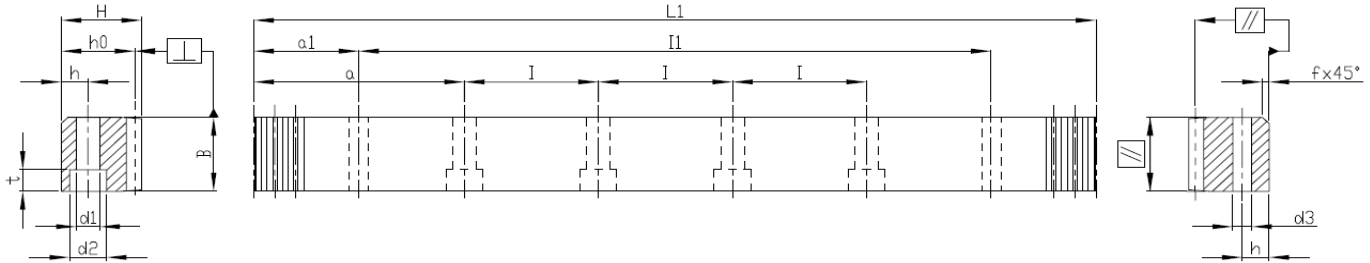

Mn	Pt ⁽¹⁾	L1	Teeth No.	B	H	ho	f	a	I	Hole No.	h	d1	d2	t	a1	II	D3	f _p ⁽²⁾	F _p ⁽³⁾	Order Code *
1	3.14159	502.66	160	15	15	14	2	62.85	125.66	4	6	5	8	5	31.3	440.05	5.7	0.008	0.029	016M11050C10
1	3.14159	1005.31	320	15	15	14	2	62.85	125.66	8	6	5	8	5	31.3	942.71	5.7	0.008	0.033	016M1100C10
1	3.14159	1507.96	480	15	15	14	2	62.85	125.66	12	6	5	8	5	31.3	1445.36	5.7	0.008	0.033	016M1150C10
2	6.28319	502.66	80	24	24	22	2	62.83	125.66	4	8	7	11	7	31.3	440.06	5.7	0.008	0.029	026M1050C10
2	6.28319	1005.31	160	24	24	22	2	62.83	125.66	8	8	7	11	7	31.3	942.71	5.7	0.008	0.034	026M1100C10
2	6.28319	1256.64	200	24	24	22	2	62.83	125.66	10	8	7	11	7	31.3	1194.04	5.7	0.008	0.034	026M1125C10
2	6.28319	1507.96	240	24	24	22	2	62.83	125.66	12	8	7	11	7	31.3	1445.36	5.7	0.008	0.034	026M1150C10
2	6.28319	1759.29	280	24	24	22	2	62.83	125.66	14	8	7	11	7	31.3	1696.69	5.7	0.008	0.034	026M1175C10
2	6.28319	2010.62	320	24	24	22	2	62.83	125.66	16	8	7	11	7	31.3	1948.02	5.7	0.009	0.038	026M1200C10
3	9.42478	508.94	54	29	29	26	2	63.62	127.23	4	9	10	15	9	34.4	440.14	7.7	0.008	0.032	036M1050C10
3	9.42478	1017.88	108	29	29	26	2	63.62	127.23	8	9	10	15	9	34.4	949.08	7.7	0.009	0.037	036M1100C10
3	9.42478	1272.35	135	29	29	26	2	63.62	127.23	10	9	10	15	9	34.4	1203.55	7.7	0.009	0.037	036M1125C10
3	9.42478	1526.81	162	29	29	26	2	63.62	127.23	12	9	10	15	9	34.4	1458.01	7.7	0.009	0.037	036M1150C10
3	9.42478	1781.28	189	29	29	26	2	63.62	127.23	14	9	10	15	9	34.4	1712.48	7.7	0.009	0.037	036M1175C10
3	9.42478	2035.75	216	29	29	26	2	63.62	127.23	16	9	10	15	9	34.4	1966.952	7.7	0.01	0.042	036M1200C10
4	12.56637	502.66	40	39	39	35	3	62.83	125.66	4	12	10	15	9	37.5	427.66	7.7	0.009	0.034	046M1050C10
4	12.56637	502.66	40	39	39	35	3	62.83	125.66	4	12	14	20	13	37.5	427.66	11.7	0.009	0.034	046M1050CS0
4	12.56637	1005.31	80	39	39	35	3	62.83	125.66	8	12	10	15	9	37.5	930.31	7.7	0.01	0.04	046M1100C10
4	12.56637	1005.31	80	39	39	35	3	62.83	125.66	8	12	14	20	13	37.5	930.31	11.7	0.01	0.04	046M1100CS0
4	12.56637	1256.64	100	39	39	35	3	62.83	125.66	10	12	10	15	9	37.5	1181.64	7.7	0.01	0.04	046M1125C10
4	12.56637	1507.96	120	39	39	35	3	62.83	125.66	12	12	10	15	9	37.5	1432.96	7.7	0.01	0.04	046M1150C10
4	12.56637	1759.29	140	39	39	35	3	62.83	125.66	14	12	10	15	9	37.5	1684.29	7.7	0.01	0.04	046M1175C10
4	12.56637	2010.62	160	39	39	35	3	62.83	125.66	16	12	10	15	9	37.5	1935.62	7.7	0.011	0.045	046M1200C10
5	15.70796	502.66	32	49	39	34	3	62.83	125.66	4	12	14	20	13	30.1	442.46	11.7	0.009	0.034	056M1050C10
5	15.70796	1005.31	64	49	39	34	3	62.83	125.66	8	12	14	20	13	30.1	945.11	11.7	0.01	0.04	056M1100C10
6	18.84956	508.94	27	59	49	43	3	63.62	127.23	4	16	18	26	17	31.4	446.14	15.7	0.009	0.034	066M1050C10
6	18.84956	1017.88	54	59	49	43	3	63.62	127.23	8	16	18	26	17	31.4	955.08	15.7	0.01	0.04	066M1100C10
8	25.13274	1005.31	40	79	79	71	3	62.83	125.66	8	25	22	33	21	26.6	952.11	19.7	0.011	0.043	086M1100C10

(1) Teeth Pitch Pt = Module x π (2) f_p = Single Pitch Error (3) F_p = Total Pitch Error

* For all models APEX also provides Rack without screw-holes. By ordering please change the 2nd last order-code position from "1" to "0". Please also refer to page 14.

Quality 6C / Carbon Steel
 Tooth Thickness Tolerance : -22 ~ 0 μm
 Straight Teeth
 Normalizing Heat-Treatment
 Teeth Ground, All Sides Milled

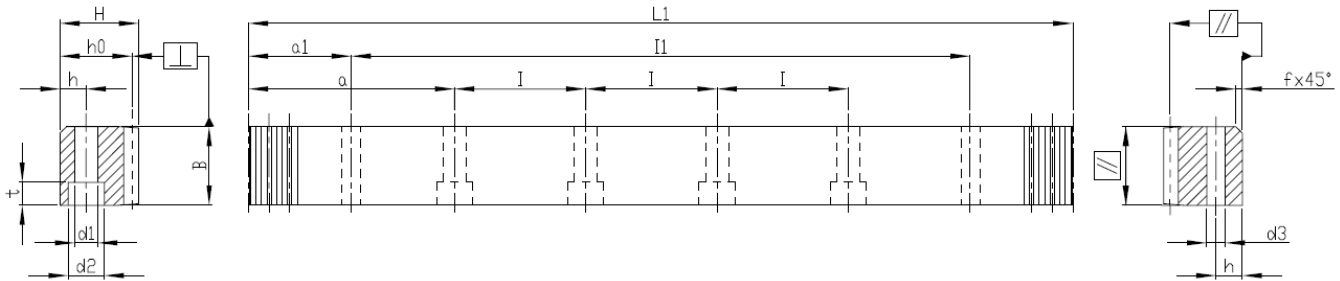

Mn	Pt ⁽¹⁾	LI	Teeth No.	B	H	ho	f	a	I	Hole No.	h	d1	d2	t	aI	II	d3	f _p ⁽²⁾	F _p ⁽³⁾	Order Code*
1	3.14159	502.66	160	15	15	14	2	62.85	125.66	4	6	5	8	5	31.3	440.05	5.7	0.008	0.029	016C1050C10
1	3.14159	1005.31	320	15	15	14	2	62.85	125.66	8	6	5	8	5	31.3	942.71	5.7	0.008	0.033	016C1100C10
2	6.28319	502.66	80	24	24	22	2	62.83	125.66	4	8	7	11	7	31.3	440.06	5.7	0.008	0.029	026C1050C10
2	6.28319	1005.31	160	24	24	22	2	62.83	125.66	8	8	7	11	7	31.3	942.71	5.7	0.008	0.034	026C1100C10
3	9.42478	508.94	54	29	29	26	2	63.62	127.23	4	9	10	15	9	34.4	440.14	7.7	0.008	0.032	036C1050C10
3	9.42478	1017.88	108	29	29	26	2	63.62	127.23	8	9	10	15	9	34.4	949.08	7.7	0.009	0.037	036C1100C10
4	12.56637	502.66	40	39	39	35	3	62.83	125.66	4	12	10	15	9	37.5	427.66	7.7	0.009	0.034	046C1050C10
4	12.56637	1005.31	80	39	39	35	3	62.83	125.66	8	12	10	15	9	37.5	930.31	7.7	0.01	0.04	046C1100C10

(1) Teeth Pitch Pt = Module $\times \pi$ (2) f_p = Single Pitch Error (3) F_p = Total Pitch Error

* For all models APEX also provides Rack without screw-holes. By ordering please change the 2nd last order-code position from "1" to "0". Please also refer to page 14.

Rack with Straight Teeth

Quality 8H / Q&T Alloy Steel
 Tooth Thickness Tolerance : -48 ~ 0 μm
 Straight Teeth
 Material Quenched and Tempered
 Teeth Milled / All Sides Milled

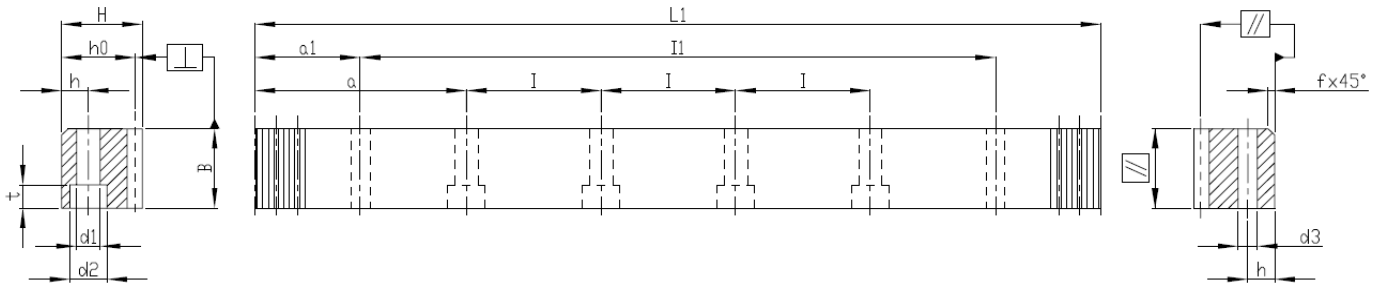

Mn	Pt ⁽¹⁾	LI	Teeth No.	B	H	ho	f	a	I	Hole No.	h	d1	d2	t	aI	II	d3	f _p ⁽²⁾	F _p ⁽³⁾	Order Code*
2	6.28319	502.66	80	25	24	22	2	62.83	125.66	4	8	7	11	7	31.3	440.06	5.7	0.015	0.057	028HI050Q10
2	6.28319	1005.31	160	25	24	22	2	62.83	125.66	8	8	7	11	7	31.3	942.71	5.7	0.016	0.066	028HI100Q10
2	6.28319	1256.64	200	25	24	22	2	62.83	125.66	10	8	7	11	7	31.3	1194.04	5.7	0.016	0.066	028HI125Q10
2	6.28319	1507.96	240	25	24	22	2	62.83	125.66	12	8	7	11	7	31.3	1445.36	5.7	0.016	0.066	028HI150Q10
2	6.28319	1759.29	280	25	24	22	2	62.83	125.66	14	8	7	11	7	31.3	1696.69	5.7	0.016	0.066	028HI175Q10
2	6.28319	2010.62	320	25	24	22	2	62.83	125.66	16	8	7	11	7	31.3	1948.02	5.7	0.018	0.074	028HI200Q10
3	9.42478	508.94	54	30	29	26	2	63.62	127.23	4	9	10	15	9	34.4	440.14	7.7	0.016	0.063	038HI050Q10
3	9.42478	1017.88	108	30	29	26	2	63.62	127.23	8	9	10	15	9	34.4	949.08	7.7	0.018	0.072	038HI100Q10
3	9.42478	1272.35	135	30	29	26	2	63.62	127.23	10	9	10	15	9	34.4	1203.55	7.7	0.018	0.072	038HI125Q10
3	9.42478	1526.81	162	30	29	26	2	63.62	127.23	12	9	10	15	9	34.4	1458.01	7.7	0.018	0.072	038HI150Q10
3	9.42478	1781.28	189	30	29	26	2	63.62	127.23	14	9	10	15	9	34.4	1712.48	7.7	0.018	0.072	038HI175Q10
3	9.42478	2035.75	216	30	29	26	2	63.62	127.23	16	9	10	15	9	34.4	1966.95	7.7	0.019	0.081	038HI200Q10
4	12.56637	502.66	40	40	39	35	3	62.83	125.66	4	12	10	15	9	37.5	427.66	7.7	0.018	0.068	048HI050Q10
4	12.56637	1005.31	80	40	39	35	3	62.83	125.66	8	12	10	15	9	37.5	930.31	7.7	0.019	0.078	048HI100Q10
4	12.56637	1256.64	100	40	39	35	3	62.83	125.66	10	12	10	15	9	37.5	1181.64	7.7	0.019	0.078	048HI125Q10
4	12.56637	1507.96	120	40	39	35	3	62.83	125.66	12	12	10	15	9	37.5	1432.96	7.7	0.019	0.078	048HI150Q10
4	12.56637	1759.29	140	40	39	35	3	62.83	125.66	14	12	10	15	9	37.5	1684.29	7.7	0.019	0.078	048HI175Q10
4	12.56637	2010.62	160	40	39	35	3	62.83	125.66	16	12	10	15	9	37.5	1935.62	7.7	0.021	0.088	048HI200Q10

(1) Teeth Pitch Pt = Module $\times \pi$ (2) f_p = Single Pitch Error (3) F_p = Total Pitch Error

* For all models APEX also provides Rack without screw-holes. By ordering please change the 2nd last order-code position from "1" to "0". Please also refer to page 14.

Especially for the application without back-support.

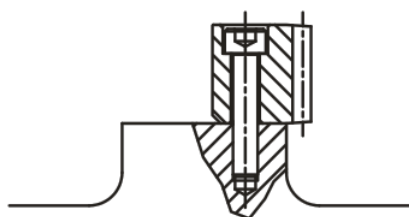

Without alignment / back-support

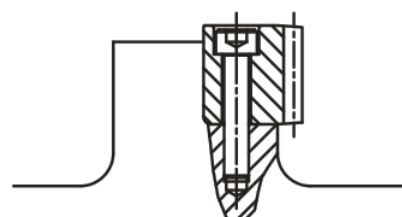

With alignment / back-support

Quality 8 / Carbon Steel
 Tooth Thickness Tolerance : -48 ~ 0 μm
 Straight Teeth
 Normalized, Teeth Milled
 All Sides Milled

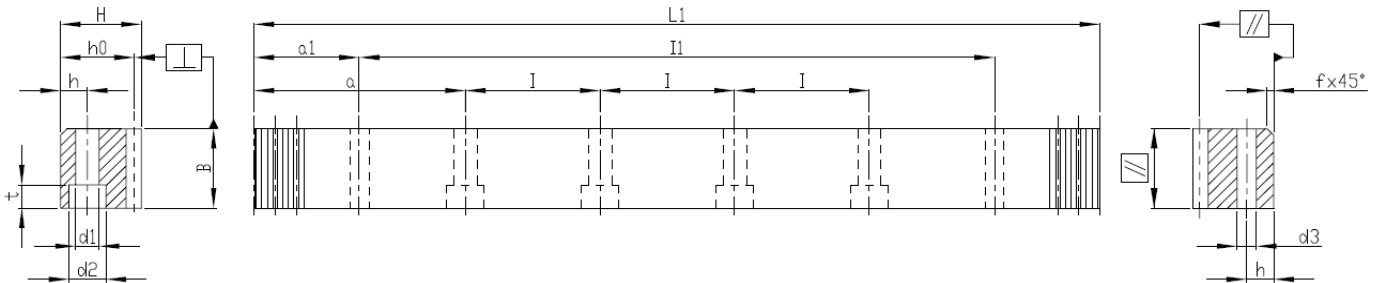

Mn	Pt ⁽¹⁾	L1	Teeth No.	B	H	ho	f	a	I	Hole No.	h	d1	d2	t	a1	I1	d3	f _p ⁽²⁾	F _p ⁽³⁾	Order Code *
1	3.14159	999.03	318	15	15	14	2	62.44	124.88	8	6	5	8	5	31.3	936.43	5.7	0.016	0.065	01081100C10
1	3.14159	1998.05	636	15	15	14	2	62.44	124.88	16	6	5	8	5	31.3	1935.45	5.7	0.018	0.074	01081200C10
1.5	4.71239	999.03	212	17	17	15.5	2	62.44	124.88	8	6	6	10	6	31.3	936.43	5.7	0.016	0.066	1J081100C10
1.5	4.71239	1248.78	265	17	17	15.5	2	62.44	124.88	10	6	6	10	6	31.3	1186.18	5.7	0.016	0.066	1J081125C10
1.5	4.71239	1498.54	318	17	17	15.5	2	62.44	124.88	12	6	6	10	6	31.3	1435.94	5.7	0.016	0.066	1J081150C10
1.5	4.71239	1748.3	371	17	17	15.5	2	62.44	124.88	14	6	6	10	6	31.3	1685.7	5.7	0.016	0.066	1J081175C10
1.5	4.71239	1998.05	424	17	17	15.5	2	62.44	124.88	16	6	6	10	6	31.3	1935.45	5.7	0.018	0.074	1J081200C10
2	6.28319	1005.31	160	26	24	22	2	62.83	125.66	8	8	7	11	7	31.3	942.71	5.7	0.016	0.066	02081100C10
2	6.28319	1256.64	200	26	24	22	2	62.83	125.66	10	8	7	11	7	31.3	1194.04	5.7	0.016	0.066	02081125C10
2	6.28319	1507.96	240	26	24	22	2	62.83	125.66	12	8	7	11	7	31.3	1445.36	5.7	0.016	0.066	02081150C10
2	6.28319	1759.29	280	26	24	22	2	62.83	125.66	14	8	7	11	7	31.3	1696.69	5.7	0.016	0.066	02081175C10
2	6.28319	2010.62	320	26	24	22	2	62.83	125.66	16	8	7	11	7	31.3	1948.02	5.7	0.018	0.074	02081200C10
3	9.42478	1017.88	108	31	29	26	2	63.62	127.23	8	9	10	15	9	34.4	949.08	7.7	0.018	0.072	03081100C10
3	9.42478	1272.35	135	31	29	26	2	63.62	127.23	10	9	10	15	9	34.4	1203.55	7.7	0.018	0.072	03081125C10
3	9.42478	1526.81	162	31	29	26	2	63.62	127.23	12	9	10	15	9	34.4	1458.01	7.7	0.018	0.072	03081150C10
3	9.42478	1781.28	189	31	29	26	2	63.62	127.23	14	9	10	15	9	34.4	1712.48	7.7	0.018	0.072	03081175C10
3	9.42478	2035.75	216	31	29	26	2	63.62	127.23	16	9	10	15	9	34.4	1966.95	7.7	0.019	0.081	03081200C10
4	12.56637	1005.31	80	41	39	35	3	62.83	125.66	8	12	10	15	9	37.5	930.31	7.7	0.019	0.078	04081100C10
4	12.56637	1005.31	80	41	39	35	3	62.83	125.66	8	12	14	20	13	37.5	930.31	11.7	0.019	0.078	04081100CS0
4	12.56637	1256.64	100	41	39	35	3	62.83	125.66	10	12	10	15	9	37.5	1181.64	7.7	0.019	0.078	04081125C10
4	12.56637	1507.96	120	41	39	35	3	62.83	125.66	12	12	10	15	9	37.5	1432.96	7.7	0.019	0.078	04081150C10
4	12.56637	1759.29	140	41	39	35	3	62.83	125.66	14	12	10	15	9	37.5	1684.29	7.7	0.019	0.078	04081175C10
4	12.56637	2010.62	160	41	39	35	3	62.83	125.66	16	12	10	15	9	37.5	1935.62	7.7	0.021	0.088	04081200C10
4	12.56637	2010.62	160	41	39	35	3	62.83	125.66	16	12	14	20	13	37.5	1935.62	11.7	0.021	0.088	04081200CS0

(1) Teeth Pitch Pt = Module $\times \pi$ (2) f_p = Single Pitch Error (3) F_p = Total Pitch Error

* For all models APEX also provides Rack without screw-holes. By ordering please change the 2nd last order-code position from "1" to "0". Please also refer to page 14.

Rack with Straight Teeth

Quality 8 / Carbon Steel
 Tooth Thickness Tolerance : -48 ~ 0 μm
 Straight Teeth
 Normalized, Teeth Milled
 All Sides Milled

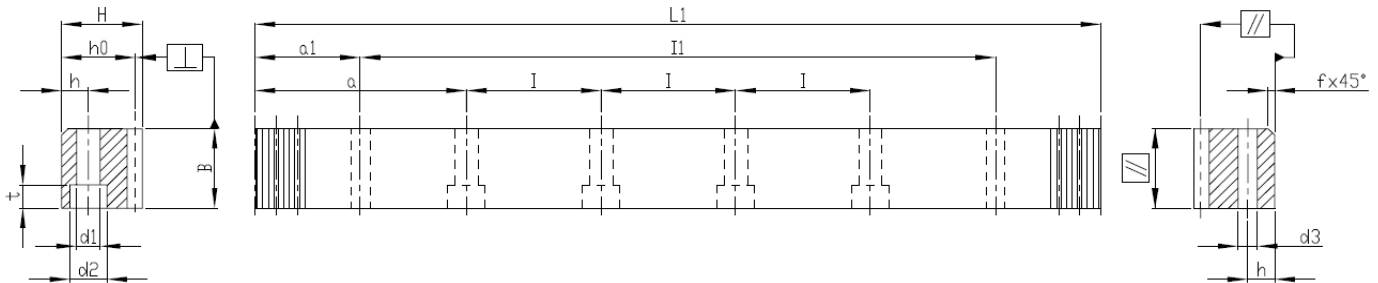

Mn	Pt ⁽¹⁾	L1	Teeth No.	B	H	h ₀	f	a	l	Hole No.	h	d1	d2	t	a1	l1	d3	f _p ⁽²⁾	F _p ⁽³⁾	Order Code *
5	15.70796	1005.31	64	50	39	34	3	62.83	125.66	8	12	14	20	13	30.1	945.11	11.7	0.019	0.078	05081100C10
5	15.70796	1256.64	80	50	39	34	3	62.83	125.66	10	12	14	20	13	30.1	1196.44	11.7	0.019	0.078	05081125C10
5	15.70796	1507.96	96	50	39	34	3	62.83	125.66	12	12	14	20	13	30.1	1447.76	11.7	0.019	0.078	05081150C10
5	15.70796	1759.29	112	50	39	34	3	62.83	125.66	14	12	14	20	13	30.1	1699.09	11.7	0.019	0.078	05081175C10
5	15.70796	2010.62	128	50	39	34	3	62.83	125.66	16	12	14	20	13	30.1	1950.42	11.7	0.021	0.088	05081200C10
6	18.84956	1017.88	54	60	49	43	3	63.62	127.23	8	16	18	26	17	31.4	955.08	15.7	0.019	0.078	06081100C10
6	18.84956	1281.77	68	60	49	43	3	63.62	127.23	10	16	18	26	17	31.4	1218.97	15.7	0.019	0.078	06081125C10
6	18.84956	1526.81	81	60	49	43	3	63.62	127.23	12	16	18	26	17	31.4	1464.01	15.7	0.019	0.078	06081150C10
6	18.84956	1790.71	95	60	49	43	3	63.62	127.23	14	16	18	26	17	31.4	1727.91	15.7	0.019	0.078	06081175C10
6	18.84956	2035.75	108	60	49	43	3	63.62	127.23	16	16	18	26	17	31.4	1972.95	15.7	0.021	0.088	06081200C10
8	25.13274	1005.31	40	81	79	71	3	62.83	125.66	8	25	22	33	21	26.6	952.11	19.7	0.022	0.084	08081100C10
8	25.13274	1256.64	50	81	79	71	3	62.83	125.66	10	25	22	33	21	26.6	1203.44	19.7	0.022	0.084	08081125C10
8	25.13274	1507.96	60	81	79	71	3	62.83	125.66	12	25	22	33	21	26.6	1454.76	19.7	0.022	0.084	08081150C10
8	25.13274	1759.29	70	81	79	71	3	62.83	125.66	14	25	22	33	21	26.6	1706.09	19.7	0.022	0.084	08081175C10
8	25.13274	2010.62	80	81	79	71	3	62.83	125.66	16	25	22	33	21	26.6	1957.42	19.7	0.024	0.095	08081200C10
10	31.41593	1005.31	32	100	99	89	3	62.83	125.66	8	32	33	48	32	125.66	753.99	19.7	0.022	0.084	10081100C10
12	37.69911	1017.88	27	120	120	108	3	63.62	127.23	8	40	39	58	38	127.23	763.42	19.7	0.026	0.09	12081100C10

(1) Teeth Pitch Pt = Module $\times \pi$ (2) f_p = Single Pitch Error (3) F_p = Total Pitch Error

* For all models APEX also provides Rack without screw-holes. By ordering please change the 2nd last order-code position from "1" to "0". Please also refer to page 14.

Quality 9 / Stainless Steel
Tooth Thickness Tolerance : -63 ~ 0 μm
Straight Teeth
Solution, Teeth Milled
All Sides Milled

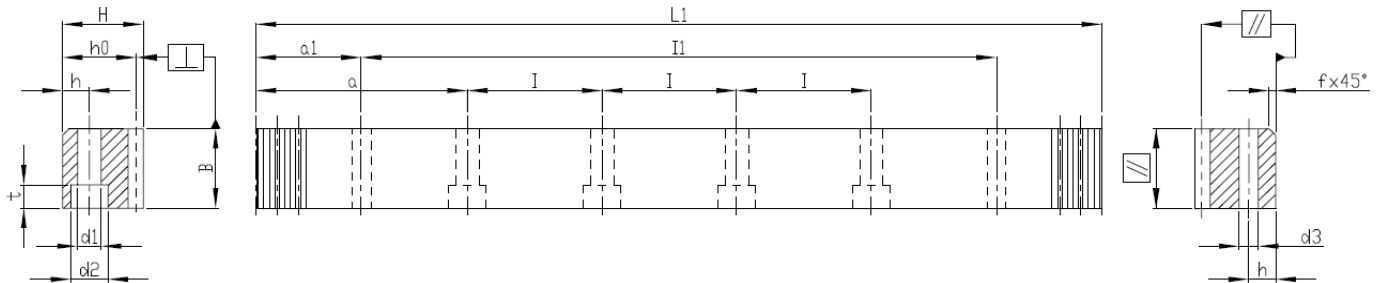

Mn	Pt ⁽¹⁾	LI	Teeth No.	B	H	ho	f	a	l	Hole No.	h	d1	d2	t	a1	l1	d3	f _p ⁽²⁾	F _p ⁽³⁾	Order Code*
1	3.14159	502.66	160	15	15	14.00	2	62.85	125.66	4	6.0	5	8	5	31.3	440.06	5.7	0.021	0.080	01091050S10
1	3.14159	1005.31	320	15	15	14.00	2	62.85	125.66	8	6.0	5	8	5	31.3	942.71	5.7	0.023	0.092	01091100S10
2	6.28319	502.66	80	26	24	22.00	2	62.83	125.66	4	8.0	7	11	7	31.3	440.06	5.7	0.021	0.080	02091050S10
2	6.28319	1005.31	160	26	24	22.00	2	62.83	125.66	8	8.0	7	11	7	31.3	942.71	5.7	0.023	0.092	02091100S10
3	9.42478	508.94	54	31	29	26.00	2	63.62	127.23	4	9.0	10	15	9	34.4	440.14	7.7	0.023	0.088	03091050S10
3	9.42478	1017.88	108	31	29	26.00	2	63.62	127.23	8	9.0	10	15	9	34.4	949.08	7.7	0.025	0.101	03091100S10
4	12.56637	502.66	40	41	39	35.00	3	62.83	125.66	4	12.0	10	15	9	37.5	427.66	7.7	0.025	0.095	04091050S10
4	12.56637	1005.31	80	41	39	35.00	3	62.83	125.66	8	12.0	10	15	9	37.5	930.31	7.7	0.027	0.109	04091100S10
4	12.56637	1507.96	120	41	39	35.00	3	62.83	125.66	12	12.0	10	15	9	37.5	1432.96	7.7	0.027	0.109	04091150S10
4	12.56637	2010.62	160	41	39	35.00	3	62.83	125.66	16	12.0	10	15	9	37.5	1935.62	7.7	0.029	0.123	04091200S10
5	15.70796	502.66	32	50	39	34.00	3	62.83	125.66	4	12.0	14	20	13	30.1	442.46	11.7	0.025	0.095	05091050S10
5	15.70796	1005.31	64	50	39	34.00	3	62.83	125.66	8	12.0	14	20	13	30.1	945.11	11.7	0.027	0.109	05091100S10
5	15.70796	1507.96	96	50	39	34.00	3	62.83	125.66	12	12.0	14	20	13	30.1	1447.76	11.7	0.027	0.109	05091150S10
5	15.70796	2010.62	128	50	39	34.00	3	62.83	125.66	16	12.0	14	20	13	30.1	1950.42	11.7	0.029	0.123	05091200S10
6	18.84956	508.94	27	60	49	43.00	3	63.62	127.23	4	16.0	18	26	17	31.4	446.14	15.7	0.025	0.095	06091050S10
6	18.84956	1017.88	54	60	49	43.00	3	63.62	127.23	8	16.0	18	26	17	31.4	955.08	15.7	0.027	0.109	06091100S10
6	18.84956	2035.75	108	60	49	43.00	3	63.62	127.23	16	16.0	18	26	17	31.4	1972.95	15.7	0.029	0.123	06091200S10

(1) Teeth Pitch Pt = Module $\times \pi$ (2) f_p = Single Pitch Error (3) F_p = Total Pitch Error

* For all models APEX also provides Rack without screw-holes. By ordering please change the 2nd last order-code position from "1" to "0". Please also refer to page 14.

Rack with Straight Teeth

Quality 10 / Carbon Steel
 Tooth Thickness Tolerance : -90 ~ 0 μm
 Straight Teeth
 Teeth Induction Hardened
 All Sides Milled

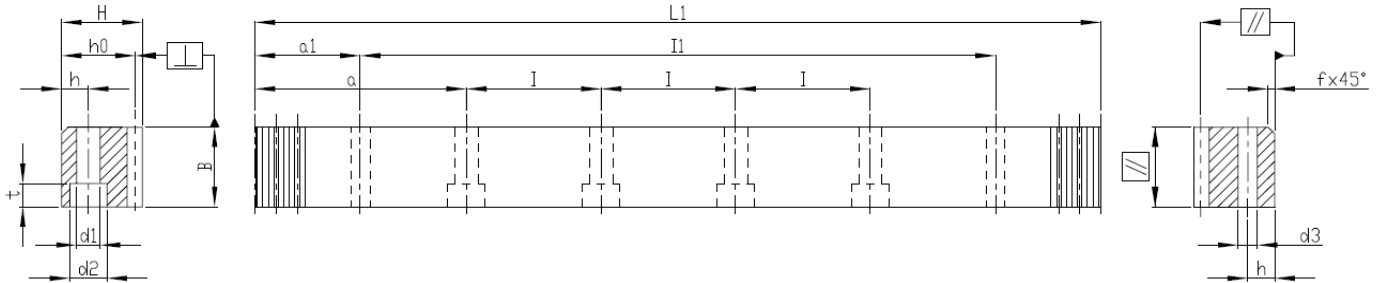

Mn	Pt ⁽¹⁾	LI	Teeth No.	B	H	ho	f	a	I	Hole No.	h	d1	d2	t	a1	II	d3	f _p ⁽²⁾	F _p ⁽³⁾	Order Code *
1	3.14159	999.03	318	15	15	14	2	62.44	124.88	8	6	5	8	5	31.3	936.43	5.7	0.037	0.146	01101100C10
1	3.14159	1998.05	636	15	15	14	2	62.44	124.88	16	6	5	8	5	31.3	1935.45	5.7	0.037	0.146	01101200C10
1.5	4.71239	999.03	212	17	17	15.5	2	62.44	124.88	8	6	6	10	6	31.3	936.43	5.7	0.037	0.148	1J101100C10
1.5	4.71239	1248.78	265	17	17	15.5	2	62.44	124.88	10	6	6	10	6	31.3	1186.18	5.7	0.037	0.148	1J101125C10
1.5	4.71239	1498.54	318	17	17	15.5	2	62.44	124.88	12	6	6	10	6	31.3	1435.94	5.7	0.037	0.148	1J101150C10
1.5	4.71239	1748.3	371	17	17	15.5	2	62.44	124.88	14	6	6	10	6	31.3	1685.7	5.7	0.037	0.148	1J101175C10
1.5	4.71239	1998.05	424	17	17	15.5	2	62.44	124.88	16	6	6	10	6	31.3	1935.45	5.7	0.041	0.165	1J101200C10
2	6.28319	1005.31	160	26	24	22	2	62.83	125.66	8	8	7	11	7	31.3	942.71	5.7	0.037	0.148	02101100C10
2	6.28319	1256.64	200	26	24	22	2	62.83	125.66	10	8	7	11	7	31.3	1194.04	5.7	0.037	0.148	02101125C10
2	6.28319	1507.96	240	26	24	22	2	62.83	125.66	12	8	7	11	7	31.3	1445.36	5.7	0.037	0.148	02101150C10
2	6.28319	1759.29	280	26	24	22	2	62.83	125.66	14	8	7	11	7	31.3	1696.69	5.7	0.037	0.148	02101175C10
2	6.28319	2010.62	320	26	24	22	2	62.83	125.66	16	8	7	11	7	31.3	1948.02	5.7	0.041	0.167	02101200C10
3	9.42478	1017.88	108	31	29	26	2	63.62	127.23	8	9	10	15	9	34.4	949.08	7.7	0.039	0.162	03101100C10
3	9.42478	1272.35	135	31	29	26	2	63.62	127.23	10	9	10	15	9	34.4	1203.55	7.7	0.039	0.162	03101125C10
3	9.42478	1526.81	162	31	29	26	2	63.62	127.23	12	9	10	15	9	34.4	1458.01	7.7	0.039	0.162	03101150C10
3	9.42478	1781.28	189	31	29	26	2	63.62	127.23	14	9	10	15	9	34.4	1712.48	7.7	0.039	0.162	03101175C10
3	9.42478	2035.75	216	31	29	26	2	63.62	127.23	16	9	10	15	9	34.4	1966.95	7.7	0.043	0.182	03101200C10
4	12.56637	1005.31	80	41	39	35	3	62.83	125.66	8	12	10	15	9	37.5	930.31	7.7	0.043	0.175	04101100C10
4	12.56637	1005.31	80	41	39	35	3	62.83	125.66	8	12	14	20	13	37.5	930.31	11.7	0.043	0.175	04101100CS0
4	12.56637	1256.64	100	41	39	35	3	62.83	125.66	10	12	10	15	9	37.5	1181.64	7.7	0.043	0.175	04101125C10
4	12.56637	1507.96	120	41	39	35	3	62.83	125.66	12	12	10	15	9	37.5	1432.96	7.7	0.043	0.175	04101150C10
4	12.56637	1759.29	140	41	39	35	3	62.83	125.66	14	12	10	15	9	37.5	1684.29	7.7	0.043	0.175	04101175C10
4	12.56637	2010.62	160	41	39	35	3	62.83	125.66	16	12	10	15	9	37.5	1935.62	7.7	0.047	0.197	04101200C10
4	12.56637	2010.62	160	41	39	35	3	62.83	125.66	16	12	14	20	13	37.5	1935.62	11.7	0.047	0.197	04101200CS0
5	15.70796	1005.31	64	50	39	34	3	62.83	125.66	8	12	14	20	13	30.1	945.11	11.7	0.043	0.175	05101100C10
5	15.70796	1256.64	80	50	39	34	3	62.83	125.66	10	12	14	20	13	30.1	1196.44	11.7	0.043	0.175	05101125C10
5	15.70796	1507.96	96	50	39	34	3	62.83	125.66	12	12	14	20	13	30.1	1447.76	11.7	0.043	0.175	05101150C10
5	15.70796	1759.29	112	50	39	34	3	62.83	125.66	14	12	14	20	13	30.1	1699.09	11.7	0.043	0.175	05101175C10
5	15.70796	2010.62	128	50	39	34	3	62.83	125.66	16	12	14	20	13	30.1	1950.42	11.7	0.047	0.197	05101200C10
6	18.84956	1017.88	54	60	49	43	3	63.62	127.23	8	16	18	26	17	31.4	955.08	15.7	0.043	0.175	06101100C10
6	18.84956	1281.77	68	60	49	43	3	63.62	127.23	10	16	18	26	17	31.4	1218.97	15.7	0.043	0.175	06101125C10
6	18.84956	1526.81	81	60	49	43	3	63.62	127.23	12	16	18	26	17	31.4	1464.01	15.7	0.043	0.175	06101150C10
6	18.84956	1790.71	95	60	49	43	3	63.62	127.23	14	16	18	26	17	31.4	1727.91	15.7	0.043	0.175	06101175C10
6	18.84956	2035.75	108	60	49	43	3	63.62	127.23	16	16	18	26	17	31.4	1972.95	15.7	0.047	0.197	06101200C10
8	25.13274	1005.31	40	81	79	71	3	62.83	125.66	8	25	22	33	21	26.6	952.11	19.7	0.049	0.188	08101100C10
8	25.13274	1256.64	50	81	79	71	3	62.83	125.66	10	25	22	33	21	26.6	1203.44	19.7	0.049	0.188	08101125C10
8	25.13274	1507.96	60	81	79	71	3	62.83	125.66	12	25	22	33	21	26.6	1454.76	19.7	0.049	0.188	08101150C10
8	25.13274	1759.29	70	81	79	71	3	62.83	125.66	14	25	22	33	21	26.6	1706.09	19.7	0.049	0.188	08101175C10
8	25.13274	2010.62	80	81	79	71	3	62.83	125.66	16	25	22	33	21	26.6	1957.42	19.7	0.053	0.212	08101200C10
10	31.41593	1005.31	32	100	99	89	3	62.83	125.66	8	32	33	48	32	125.66	753.99	19.7	0.049	0.188	10101100C10
12	37.69911	1017.88	27	120	120	108	3	63.62	127.23	8	40	39	58	38	127.23	763.42	19.7	0.059	0.202	12101100C10

(1) Teeth Pitch Pt = Module x π (2) fp = Single Pitch Error (3) Fp = Total Pitch Error

* For all models APEX also provides Rack without screw-holes. By ordering please change the 2nd last order-code position from "I" to "O". Please also refer to page I4.

Rack with Straight Teeth

(with Linear-Guide Interface, 90° Type)

Quality 6 / Carbon Steel
 Tooth Thickness Tolerance : -22 ~ 0 μm
 Straight Teeth
 Teeth Induction Hardened and Ground
 All Sides Ground

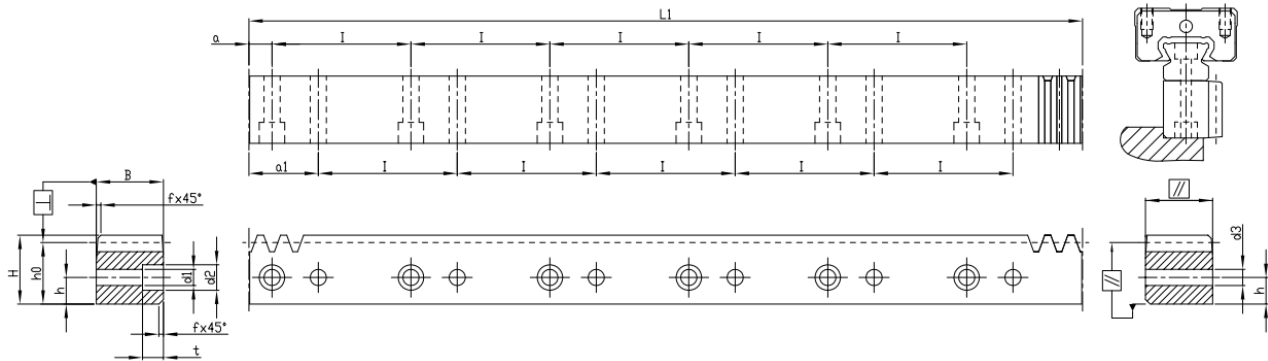

Mn	Pt ⁽¹⁾	LI	Teeth No.	B	H	ho	f	a	l	Hole No.	h	dl	d2	t	al	d3	fp ⁽²⁾	Fp ⁽³⁾	Order Code
1.591	5	960	192	19	19.50	17.91	1	10	60	16	7.5	4.5	7.5	5.3	30	4.5	0.008	0.034	1K061100C10A1
1.591	5	960	192	24	24.50	22.91	1	10	60	16	10.0	6	9.5	8.5	30	6	0.008	0.034	1K061100CS0A1
3.183	10	960	96	29	29.75	26.57	2	10	60	16	11.5	7	11.0	9.0	30	7	0.009	0.037	3B061100C10A1
4.244	13.33	960	72	39	39.75	35.51	2	20	80	12	14.0	10	15.0	9.0	40	10	0.010	0.040	4D061100C10A1

Quality 8 / Carbon Steel
 Tooth Thickness Tolerance : -48 ~ 0 μm
 Straight Teeth
 Teeth Milled, All Side Milled

Mn	Pt ⁽¹⁾	LI	Teeth No.	B	H	ho	f	a	l	Hole No.	h	dl	d2	t	al	d3	fp ⁽²⁾	Fp ⁽³⁾	Order Code
1.591	5	1920	384	20	19.50	17.91	1	10	60	32	7.5	4.5	7.5	5.3	30	4.5	0.018	0.074	1K081200C10A1
1.591	5	1920	384	25	24.50	22.91	1	10	60	32	10.0	6.0	9.5	8.5	30	6.0	0.018	0.074	1K081200CS0A1
3.183	10	1920	192	30	29.75	26.57	2	10	60	32	11.5	7.0	11.0	9.0	30	7.0	0.019	0.081	3B081200C10A1
4.244	13.33	1920	144	40	39.75	35.51	2	20	80	24	14.0	10.0	15.0	9.0	40	10.0	0.021	0.088	4D081200C10A1

(1) Teeth Pitch Pt = Module × π (2) fp = Single Pitch Error (3) Fp = Total Pitch Error

Rack with Straight Teeth

(with Linear-Guide Interface, 180° Type)

Quality 6 / Carbon Steel
 Tooth Thickness Tolerance : -22 ~ 0 μm
 Straight Teeth
 Teeth Induction Hardened and Ground
 All Sides Ground

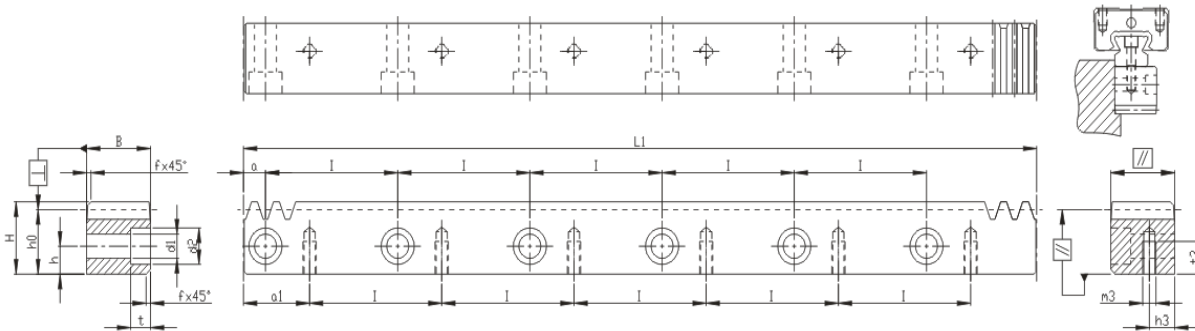

Mn	Pt ⁽¹⁾	LI	Teeth No.	B	H	ho	f	a	l	Hole No.	h	d1	d2	t	a1	m3	h3	t3	f _p ⁽²⁾	F _p ⁽³⁾	Order Code
1.591	5.00	960	192	19	19.50	17.91	1	10	60	16	7.5	6	9.5	6	30	M4	7.5	8.0	0.008	0.034	1K061100C10A2
1.591	5.00	960	192	24	24.50	22.91	1	10	60	16	10.0	7	11	7	30	M5	10.0	11.0	0.008	0.034	1K061100CS0A2
3.183	10.00	960	96	29	29.75	26.57	2	10	60	16	11.5	10	15	9	30	M6	11.5	13.5	0.009	0.037	3B061100C10A2
4.244	13.33	960	72	39	39.75	35.51	2	20	80	12	14.0	12	18	12	40	M8	14.0	16.0	0.010	0.040	4D061100C10A2

Quality 8 / Carbon Steel
 Tooth Thickness Tolerance : -48 ~ 0 μm
 Straight Teeth
 Teeth Milled, All Side Milled

Mn	Pt ⁽¹⁾	LI	Teeth No.	B	H	ho	f	a	l	Hole No.	h	d1	d2	t	a1	m3	h3	t3	f _p ⁽²⁾	F _p ⁽³⁾	Order Code
1.591	5.00	1920	384	20	19.5	17.91	1	10	60	32	7.5	6	9.5	6	30	M4	7.5	8.0	0.018	0.074	1K081200C10A2
1.591	5.00	1920	384	25	24.5	22.91	1	10	60	32	10.0	7	11.0	7	30	M5	10.0	11.0	0.018	0.074	1K081200CS0A2
3.183	10.00	1920	192	30	29.75	26.57	2	10	60	32	11.5	10	15.0	9	30	M6	11.5	13.5	0.019	0.081	3B081200C10A2
4.244	13.33	1920	144	40	39.75	35.51	2	20	80	24	14.0	12	18.0	12	40	M8	14.0	16.0	0.021	0.088	4D081200C10A2

(1) Teeth Pitch Pt = Module x π (2) fp = Single Pitch Error (3) Fp = Total Pitch Error

Pinion with Straight Teeth

(Interface : Curvic Plate / EN ISO 9409-I-A)

Quality DIN 4 / Alloy Steel

Tooth Thickness Tolerance : e24

Straight Teeth

Case-Hardened and Teeth Ground

Bolt Circle Ø50

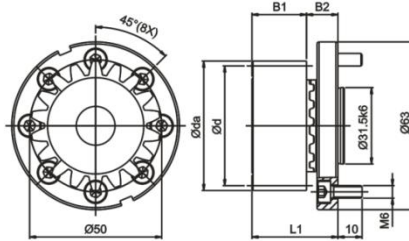

Fig. B

Mn	z ⁽¹⁾	x ⁽²⁾	da ⁽³⁾	d ⁽⁴⁾	dw ⁽⁵⁾	B1	B2	L1	L ⁽⁶⁾	Fig	Order Code	
											Set	Pinion only
2	21	0.5	48	42	44	26	15	41	131.947	B	A02121B050	A02121

Bolt Circle Ø63

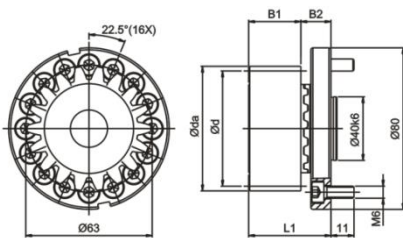

Fig. A

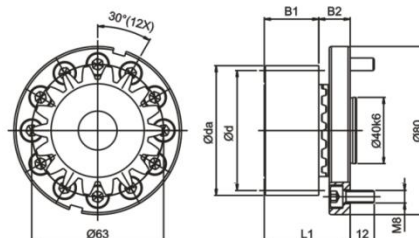

Fig. C

Mn	z ⁽¹⁾	x ⁽²⁾	da ⁽³⁾	d ⁽⁴⁾	dw ⁽⁵⁾	B1	B2	L1	L ⁽⁶⁾	Fig	Order Code	
											Set	Pinion only
2	21	0.5	48	42	44	26	15	41	131.947	A	A02121A063	A02121
							19.5	45.5			C	

Bolt Circle Ø80

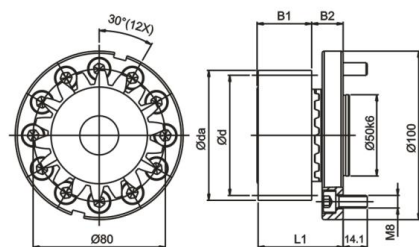

Fig. A

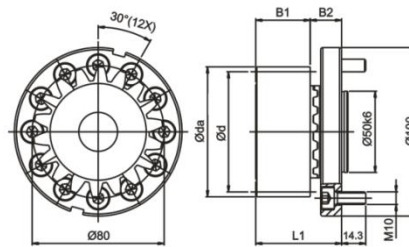

Fig. C

Mn	z ⁽¹⁾	x ⁽²⁾	da ⁽³⁾	d ⁽⁴⁾	dw ⁽⁵⁾	B1	B2	L1	L ⁽⁶⁾	Fig	Order Code	
											Set	Pinion only
3	19	0.1667	64	57	58	31	21.5	52.5	179.071	A	A03119A080	A03119
											C	

(1) Number of teeth (2) Profile modification factor (3) Diameter of addendum circle (4) Pitch circle diameter
 (5) Working pitch circle diameter (6) Pitch circle length $L = \pi \times d$

Pinion with Straight Teeth

(Interface : Curvic Plate / EN ISO 9409-I-A)

Quality DIN 4 / Alloy Steel
 Tooth Thickness Tolerance : e24
 Straight Teeth
 Case-Hardened and Teeth Ground

Bolt Circle $\varnothing 125$

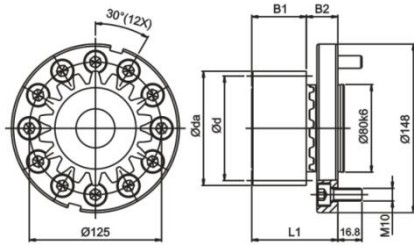

Fig. A

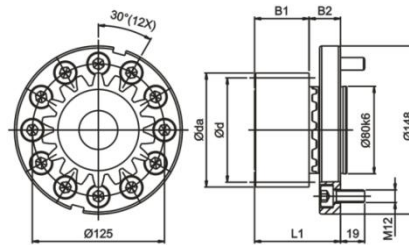

Fig. C

Mn	z ⁽¹⁾	x ⁽²⁾	da ⁽³⁾	d ⁽⁴⁾	dw ⁽⁵⁾	B1	B2	L1	L ⁽⁶⁾	Fig	Order Code	
											Set	Pinion only
4	19	0.6875	89.5	76	81.5	41	29	70	238.761	A	A04119A125	A04119
										C	A04119C125	

Bolt Circle $\varnothing 140 / \varnothing 145$

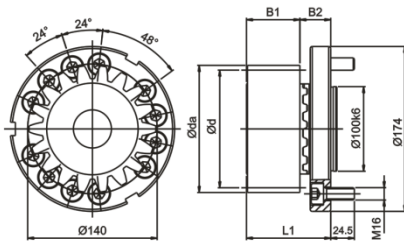

Fig. A

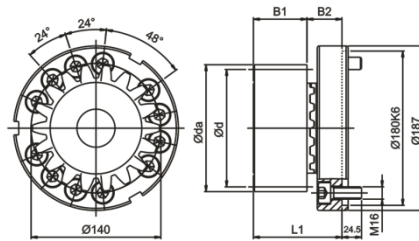

Fig. B

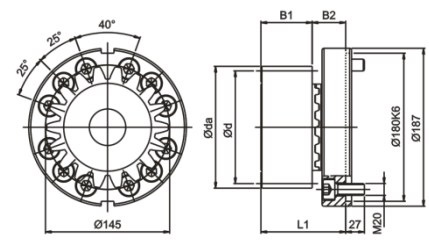

Fig. C

Mn	z ⁽¹⁾	x ⁽²⁾	da ⁽³⁾	d ⁽⁴⁾	dw ⁽⁵⁾	B1	B2	L1	L ⁽⁶⁾	Fig	Order Code	
											Set	Pinion only
5	19	0.3	108	95	98	51	38	89	298.451	A	A05119A140	A05119
										B	A05119B140	
										C	A05119C145	

Quality DIN 4 / Alloy Steel
 Tooth Thickness Tolerance : e24
 Straight Teeth
 Case-Hardened and Teeth Ground

Bolt Circle Ø160 / Ø166

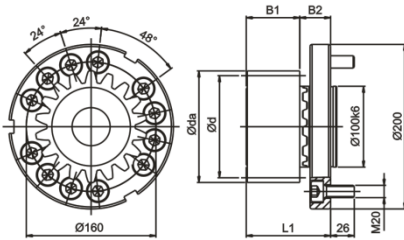

Fig. A

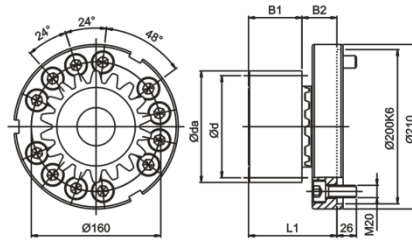

Fig. B

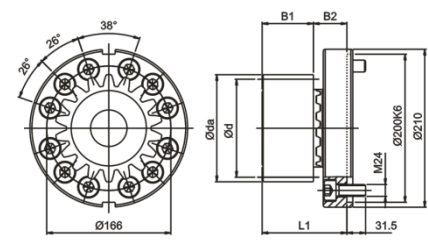
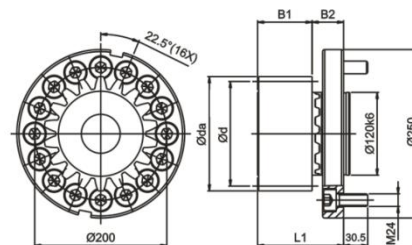

Fig. C

Mn	z ⁽¹⁾	x ⁽²⁾	da ⁽³⁾	d ⁽⁴⁾	dw ⁽⁵⁾	B1	B2	L1	L ⁽⁶⁾	Fig	Order Code	
											Set	Pinion only
6	19	0.25	129	114	117	61	49	110	358.142	A	A06119A160	A06119
										B	A06119B160	
										C	A06119C166	

Bolt Circle Ø200



Mn.	z ⁽¹⁾	x ⁽²⁾	da ⁽³⁾	d ⁽⁴⁾	dw ⁽⁵⁾	B1	B2	L1	L ⁽⁶⁾	Order Code	
										Set	Pinion only
8	16	0.3125	149	128	133	81	50	131	402.124	A08116A200	A08116

(1) Number of teeth (2) Profile modification factor (3) Diameter of addendum circle (4) Pitch circle diameter
 (5) Working pitch circle diameter (6) Pitch circle length $L = \pi \times d$

Pinion with Straight Teeth

(Interface : Curvic Plate / EN ISO 9409-I-A)

Quality DIN 4 / Alloy Steel
 Tooth Thickness Tolerance : e24
 Straight Teeth
 Case-Hardened and Teeth Ground

Bolt Circle Ø250

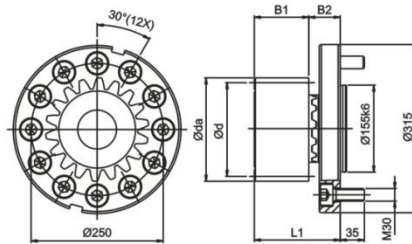

Mn.	z ⁽¹⁾	x ⁽²⁾	da ⁽³⁾	d ⁽⁴⁾	dw ⁽⁵⁾	B1	B2	L1	L ⁽⁶⁾	Order Code	
										Set	Pinion only
10	15	0.45	179	150	159	101	62	163	471.239	A10115A250	A10115

(1) Number of teeth (2) Profile modification factor (3) Diameter of addendum circle (4) Pitch circle diameter
 (5) Working pitch circle diameter (6) Pitch circle length $L = \pi * d$

Pinion material carburized, the surface hardness reaches to 60 HRc after case hardening
 Teeth surface ground in order to reduce noise and improve wear resistance
 Accessories include hexagon socket head cap screws (Strength 12.9 · DIN 912)

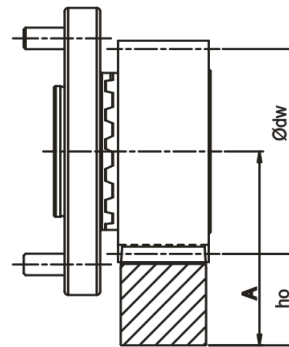
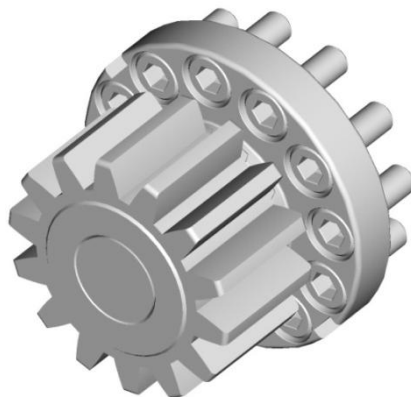

$$A = h_o + \frac{\phi dw}{2}$$

In Table 9, the maximum permissible torque of the Curvic Plate pinion and the rack is calculated on the basis of a speed of 1.5 m/s and providing good lubrication (using an automatic lubrication system or manually applied grease every day), the tooth root strength factor $S_F \geq 1.4$, tooth surface strength coefficient $S_H \geq 1$, the safety factor $S_B \cong 1$, and the required service life of 20,000 hours. By higher speed, the max. permissible torque reduced. The user needs to increase the safety factor for the application.

Backlash changes by different center height. Please contact APEX under WWW.APEXDYNA.COM.

Table 9. The max. permitted torque and feed-force of pinion with Curvic Plate

Pinion \ Rack			Quality	Q4	Q5H	Q5		Q6	Q6M	Q6C	Q8H	Q8	Q9	Q10	
			Material	Carbon Steel	Alloy Steel		Carbon Steel	Carbon Steel	Carbon Steel	Carbon Steel	Carbon Steel	Q&T Alloy Steel	Carbon Steel	Stainless Steel	Carbon Steel
			Heat Treatment	Induction Hardening	Case Hardening	Carburized Induction	Induction Hardening	Induction Hardening	Induction Hardening	Normalizing	Quenched Tempered	Normalizing	Solution	Induction Hardening	
Mn	z ⁽¹⁾	dw ⁽⁵⁾	Max. Torque * and Feed-Force												
2	21	44	F _{2T} ⁽⁸⁾ (N)		7,857	7,857		6,429	6,429	1,190	1,905	1,190	714	4,048	
			T _{2B} ⁽⁹⁾ (Nm)		165	165		135	135	25	40	25	15	85	
3	19	58	F _{2T} ⁽⁸⁾ (N)		14,211	14,211		13,860	13,860	4,386	7,018	3,684	1,754	9,825	
			T _{2B} ⁽⁹⁾ (Nm)		405	405		395	395	125	200	105	50	280	
	21	66	F _{2T} ⁽⁸⁾ (N)		14,921	14,921		12,381	12,381	2,698	4,444	2,540	1,270	9,683	
			T _{2B} ⁽⁹⁾ (Nm)		470	470		390	390	85	140	80	40	305	
4	19	81.5	F _{2T} ⁽⁸⁾ (N)		27,105		26,974	26,711	26,711	8,289	13,289	7,500	3,026	20,921	
			T _{2B} ⁽⁹⁾ (Nm)		1,030		1,025	1,015	1,015	315	505	285	115	795	
5	19	98	F _{2T} ⁽⁸⁾ (N)	44,316	44,316		44,316	44,211	44,211			14,316	5,263	36,211	
			T _{2B} ⁽⁹⁾ (Nm)	2,105	2,105		2,105	2,100	2,100			680	250	1,720	
6	19	117	F _{2T} ⁽⁸⁾ (N)	63,333	63,333		63,246	63,246	63,246			22,982	9,474	54,123	
			T _{2B} ⁽⁹⁾ (Nm)	3,610	3,610		3,605	3,605	3,605			1,310	540	3,085	
8	16	133	F _{2T} ⁽⁸⁾ (N)	93,125	93,125		93,125	93,125	93,125			34,531		76,563	
			T _{2B} ⁽⁹⁾ (Nm)	5,960	5,960		5,960	5,960	5,960			2,210		4,900	
10	15	159	F _{2T} ⁽⁸⁾ (N)	144,000	144,000		144,000	144,000	144,000			54,000		131,467	
			T _{2B} ⁽⁹⁾ (Nm)	10,800	10,800		10,800	10,800	10,800			4,050		9,860	

* The Maximal Driving Torque is also to be understood as the Maximal Acceleration Torque T_{2B}.

The Emergency Stop Torque T_{2NOT} = 2 x T_{2B}, under the condition limited 1000 times in the whole service period.

(1) Number of Teeth (5) Working Pitch Circle Diameter (in mm) (8) Maximum Feed-Force (9) Maximum Driving Torque

Pinion with Straight Teeth

(Interface : Welded Plate / EN ISO 9409-I-A)

Quality DIN 4 / Alloy Steel
 Tooth Thickness Tolerance : e24
 Straight Teeth
 Case-Hardened and Teeth Ground

Bolt Circle Ø 50

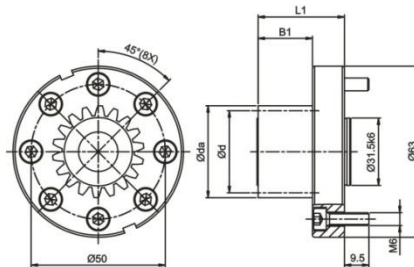

Mn	z ⁽¹⁾	x ⁽²⁾	da ⁽³⁾	d ⁽⁴⁾	dw ⁽⁵⁾	BI	LI	L ⁽⁶⁾	Order Code
2	13	0.366	31.464	26	27.464	26	41	81.681	B02113A050
	17	-0.012	37.952	34	33.952	26	41	106.814	B02117A050

Bolt Circle Ø 63

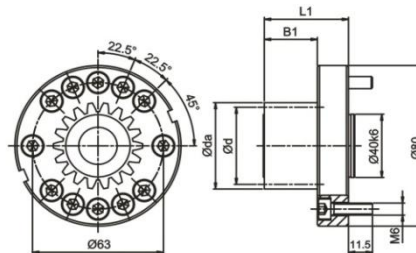

Mn	z ⁽¹⁾	x ⁽²⁾	da ⁽³⁾	d ⁽⁴⁾	dw ⁽⁵⁾	BI	LI	L ⁽⁶⁾	Order Code
2	13	0.366	31.464	26	27.464	26	41	81.681	B02113A063
	17	-0.012	37.952	34	33.952	26	41	106.814	B02117A063
	24	0.202	52.808	48	48.808	26	41	150.796	B02124A063
3	13	0.366	47.196	39	41.196	32.5	47.5	122.522	B03113A063

(1) Number of teeth (2) Profile modification factor (3) Diameter of addendum circle (4) Pitch circle diameter
 (5) Working pitch circle diameter (6) Pitch circle length $L = \pi \times d$

Quality DIN 4 / Alloy Steel
 Tooth Thickness Tolerance : e24
 Straight Teeth
 Case-Hardened and Teeth Ground

Bolt Circle Ø 80

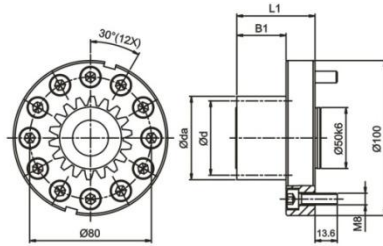

Mn	z ⁽¹⁾	x ⁽²⁾	da ⁽³⁾	d ⁽⁴⁾	dw ⁽⁵⁾	BI	LI	L ⁽⁶⁾	Order Code
2	13	0.366	31.464	26	27.464	26	46	81.681	B02113A080
	24	0.202	52.808	48	48.808	26	46	150.796	B02124A080
3	13	0.366	47.196	39	41.196	32.5	52.5	122.522	B03113A080
	20	0.08	66.48	60	60.48	32.5	52.5	188.496	B03120A080
4	13	0.366	62.928	52	54.928	45	65	163.363	B04113A080

Bolt Circle Ø 125

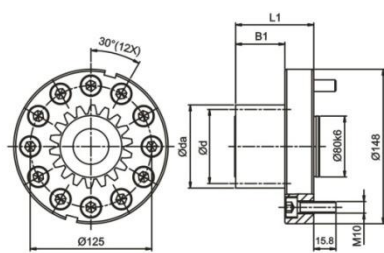

Fig. A

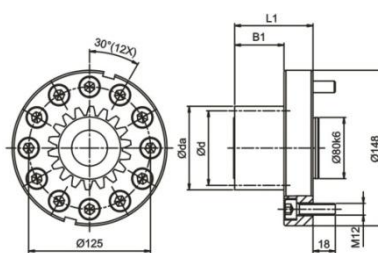

Fig. C

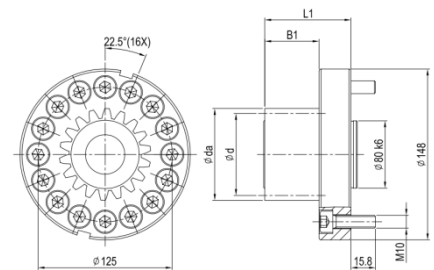

Fig. D

Mn	z ⁽¹⁾	x ⁽²⁾	da ⁽³⁾	d ⁽⁴⁾	dw ⁽⁵⁾	BI	LI	L ⁽⁶⁾	Fig	Order Code
3	13	0.366	47.196	39	41.196	32.5	57.5	122.522	A	B03113A125
									C	B03113C125
									D	B03113D125
	20	0.08	66.48	60	60.48	32.5	57.5	188.496	A	B03120A125
									C	B03120C125
									D	B03120D125
									D	B03127D125
27	0.294	88.764	81	82.764	32.5	57.5	254.469	C	B03127C125	
								D	B03127D125	
33	0.477	107.862	99	101.862	32.5	57.5	311.018	D	B03133D125	
4	13	0.366	62.928	52	54.928	45	70	163.363	A	B04113A125
									C	B04113C125
									D	B04113D125
	20	0.19	89.52	80	81.52	45	70	251.327	A	B04120A125
									C	B04120C125
									D	B04120D125
	21	0.11	92.88	84	84.88	45	70	263.894	A	B04121A125
									C	B04121C125
									D	B04121D125
									D	B04121D125
24	0.202	105.616	96	97.616	45	70	301.593	A	B04124A125	
								C	B04124C125	
								D	B04124D125	

Pinion with Straight Teeth

(Interface : Welded Plate / EN ISO 9409-1-A)

Quality DIN 4 / Alloy Steel

Tooth Thickness Tolerance : e24

Straight Teeth

Case-Hardened and Teeth Ground

Mn	z ⁽¹⁾	x ⁽²⁾	da ⁽³⁾	d ⁽⁴⁾	dw ⁽⁵⁾	BI	LI	L ⁽⁶⁾	Fig	Order Code
5	13	0.366	78.66	65	68.66	55	80	204.204	A	B05113A125
									C	B05113C125
									D	B05113D125
	17	-0.012	94.88	85	84.88	55	80	267.035	C	B05117C125
									D	B05117D125
									A	B05119A125
19	0.049	105.49	95	95.49	55	80	298.451	C	B05119C125	
								D	B05119D125	
								A	B06113A125	
6	13	0.366	94.392	78	82.392	65	90	245.044	C	B06113C125
									D	B06113D125
									A	B06114A125
	14	0.397	100.764	84	88.764	65	90	263.894	A	B06114A125
									A	B06116A125
									A	B06116A125

Bolt Circle Ø140

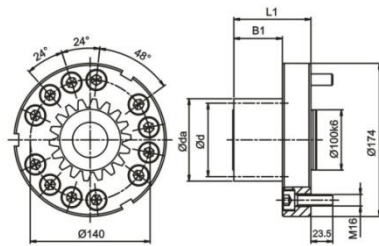

Fig. A

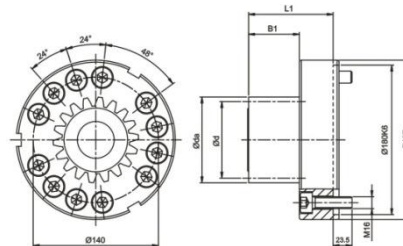

Fig. B

Mn	z ⁽¹⁾	x ⁽²⁾	da ⁽³⁾	d ⁽⁴⁾	dw ⁽⁵⁾	BI	LI	L ⁽⁶⁾	Fig	Order Code
4	13	0.366	62.928	52	54.928	45	79	163.363	A	B04113A140
									B	B04113B140
	20	0.19	89.52	80	81.52	45	79	251.327	A	B04120A140
									B	B04120B140
	21	0.11	92.88	84	84.88	45	79	263.894	A	B04121A140
									B	B04121B140
5	15	0.227	87.27	75	77.27	55	89	235.619	A	B05115A140
									B	B05115B140
	20	0.08	110.8	100	100.8	55	89	314.159	A	B05120A140
									B	B05120B140
6	13	0.366	94.392	78	82.392	65	99	245.044	A	B06113A140
									B	B06113B140
	17	-0.012	113.856	102	101.856	65	99	320.442	A	B06117A140
									B	B06117B140

Quality DIN 4 / Alloy Steel
 Tooth Thickness Tolerance : e24
 Straight Teeth
 Case-Hardened and Teeth Ground

Bolt Circle Ø160

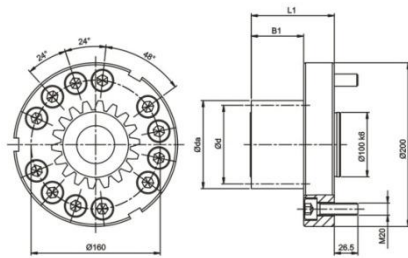

Fig. A

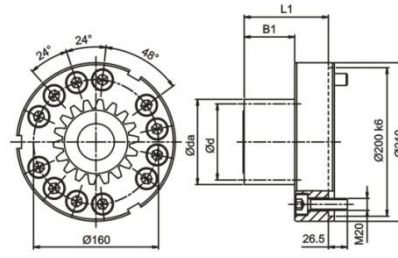

Fig. B

Mn	z ⁽¹⁾	x ⁽²⁾	da ⁽³⁾	d ⁽⁴⁾	dw ⁽⁵⁾	B1	L1	L ⁽⁶⁾	Fig	Order Code
5	13	0.366	78.66	65	68.66	55	100	204.204	A	B05113A160
									B	B05113B160
	20	0.08	110.8	100	100.8	55	100	314.159	A	B05120A160
									B	B05120B160
6	13	0.366	94.392	78	82.392	65	110	245.044	A	B06113A160
									B	B06113B160
	17	-0.012	113.856	102	101.856	65	110	320.442	A	B06117A160
									B	B06117B160
	19	0.049	126.588	114	114.588	65	110	358.142	A	B06119A160
									B	B06119B160
8	13	0.366	125.856	104	109.856	85	130	326.726	A	B08113A160
									B	B08113B160

(1) Number of teeth (2) Profile modification factor (3) Diameter of addendum circle (4) Pitch circle diameter
 (5) Working pitch circle diameter (6) Pitch circle length $L = \pi \times d$

Pinion material carburized, the surface hardness reached 60 HRC

Teeth surface ground in order to reduce noise and improve wear resistance

Accessories include hexagon socket head cap screws (Strength 12.9 , DIN 912)

The maximum transmission torque is limited by cap screw, the permissible torque as below table:

Bolt Circle	Cap Screw	Maximum Transmission Torque (Nm)
Ø50	M6 X 8 PCS	175
Ø63	M6 X 12 PCS	335
Ø80	M8 X 12 PCS	810
Ø125	M10 X 12 PCS	2,055
	M10 X 16 PCS	2,745
	M12 X 12 PCS	3,060
Ø140	M16 X 12 PCS	6,620
Ø145	M20 X 12 PCS	10,885
Ø160	M20 X 12 PCS	12,000

Pinion with Straight Teeth

(Interface : Welded Plate / EN ISO 9409-1-A)

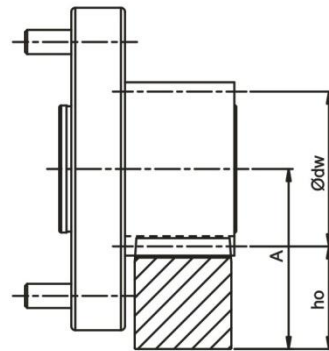

$$A = h_o + \frac{\phi_{dw}}{2}$$

In Table 10, the maximum permissible torque of the pinion Welded Plate and the rack is calculated on the basis of a speed of 1.5 m/s and providing good lubrication (using an automatic lubrication system or manually applied grease every day), the tooth root strength factor $S_F \geq 1.4$, tooth surface strength coefficient $S_H \geq 1$, the safety factor $S_B \cong 1$, and the required service life of 20,000 hours. By higher speed, the max. permissible torque reduced. The user needs to increase the safety factor for the application. Backlash changes by different center height. Please contact APEX under WWW.APEXDYNA.COM.

Pinion with Straight Teeth

(Interface : Welded Plate / EN ISO 9409-1-A)

Table 10. The max. permitted torque and feed-force of pinion Welded Plate

Pinion Rack			Quality	Q4	Q5H	Q5		Q6	Q6M	Q6C	Q8H	Q8	Q9	Q10	
			Material	Carbon Steel	Alloy Steel		Carbon Steel	Carbon Steel	Carbon Steel	Carbon Steel	Carbon Steel	Q&T Alloy Steel	Carbon Steel	Stainless Steel	Carbon Steel
			Heat Treatment	Induction Hardening	Case Hardening	Carburized Induction	Induction Hardening	Induction Hardening	Induction Hardening	Normalizing	Quenched Tempered	Normalizing	Solution	Induction Hardening	
Mn	z ⁽¹⁾	dw ⁽⁵⁾	Max. Torque * and Feed-Force												
2	13	27.264	F _{2T} ⁽⁸⁾ (N)		4,231	4,231		4,231	4,231	1,154	1,538	769	385	1,923	
			T _{2B} ⁽⁹⁾ (Nm)		55	55		55	55	15	20	10	5	25	
	17	33.952	F _{2T} ⁽⁸⁾ (N)		5,000	5,000		5,000	5,000	1,471	2,353	1,471	588	2,059	
			T _{2B} ⁽⁹⁾ (Nm)		85	85		85	85	25	40	25	10	35	
	24	48.808	F _{2T} ⁽⁸⁾ (N)		8,333	8,333		6,875	6,875	1,667	2,292	1,458	833	3,542	
			T _{2B} ⁽⁹⁾ (Nm)		200	200		165	165	40	55	35	20	85	
3	13	41.196	F _{2T} ⁽⁸⁾ (N)		8,462	8,462		8,462	8,462	2,308	3,333	2,051	1,025	4,615	
			T _{2B} ⁽⁹⁾ (Nm)		165	165		165	165	45	65	40	20	90	
	20	60.48	F _{2T} ⁽⁸⁾ (N)		14,833	14,833		13,333	13,333	2,833	4,500	2,333	1,333	10,000	
			T _{2B} ⁽⁹⁾ (Nm)		445	445		400	400	85	135	70	40	300	
	27	82.764	F _{2T} ⁽⁸⁾ (N)		15,679	15,679		13,086	13,086	4,815	7,654	4,074	1,728	9,630	
			T _{2B} ⁽⁹⁾ (Nm)		635	635		530	530	195	310	165	70	390	
	33	101.862	F _{2T} ⁽⁸⁾ (N)		15,455	15,455		12,828	12,828	6,566	9,596	5,960	1,717	9,394	
			T _{2B} ⁽⁹⁾ (Nm)		765	765		635	635	325	475	295	85	465	
4	13	54.928	F _{2T} ⁽⁸⁾ (N)		16,154		16,154	16,154	4,615	7,692	3,846	1,923	10,192		
			T _{2B} ⁽⁹⁾ (Nm)		420		420	420	120	200	100	50	265		
	20	81.52	F _{2T} ⁽⁸⁾ (N)		28,250		24,375	24,000	24,000	6,250	10,125	4,375	2,375	19,500	
			T _{2B} ⁽⁹⁾ (Nm)		1,130		975	960	960	250	405	175	95	780	
	21	84.88	F _{2T} ⁽⁸⁾ (N)		28,690		24,643	24,286	24,286	6,905	11,190	5,000	2,500	19,167	
			T _{2B} ⁽⁹⁾ (Nm)		1,205		1,035	1,020	1,020	290	470	210	105	805	
	24	97.616	F _{2T} ⁽⁸⁾ (N)		28,542		24,479	24,063	24,063	8,646	13,542	6,979	2,813	18,854	
			T _{2B} ⁽⁹⁾ (Nm)		1,370		1,175	1,155	1,155	415	650	335	135	905	
5	13	68.66	F _{2T} ⁽⁸⁾ (N)	26,461	26,461		26,461	25,846	25,846			7,385	3,231	18,462	
			T _{2B} ⁽⁹⁾ (Nm)	860	860		860	840	840			240	105	600	
	15	77.27	F _{2T} ⁽⁸⁾ (N)	30,533	30,533		30,533	29,867	29,867			9,867	3,867	22,133	
			T _{2B} ⁽⁹⁾ (Nm)	1,145	1,145		1,145	1,120	1,120			370	145	830	
	17	84.88	F _{2T} ⁽⁸⁾ (N)	31,647	31,647		31,647	30,941	30,941			12,706	4,471	22,706	
			T _{2B} ⁽⁹⁾ (Nm)	1,345	1,345		1,345	1,315	1,315			540	190	965	
	19	95.49	F _{2T} ⁽⁸⁾ (N)	39,368	39,368		39,368	38,947	38,947			15,052	5,158	31,053	
			T _{2B} ⁽⁹⁾ (Nm)	1,870	1,870		1,870	1,850	1,850			715	245	1,745	
20	100.8	F _{2T} ⁽⁸⁾ (N)	38,900	43,400		38,900	38,500	38,500			9,700	3,800	32,500		
		T _{2B} ⁽⁹⁾ (Nm)	1,945	2,170		1,945	1,925	1,925			485	190	1,625		
6	13	82.392	F _{2T} ⁽⁸⁾ (N)	38,974	38,974		38,974	38,462	38,462			12,179	4,872	29,487	
			T _{2B} ⁽⁹⁾ (Nm)	1,520	1,520		1,520	1,500	1,500			475	190	1,150	
	14	88.764	F _{2T} ⁽⁸⁾ (N)	44,286	44,286		44,286	43,929	43,929			13,690	6,548	34,881	
			T _{2B} ⁽⁹⁾ (Nm)	1,860	1,860		1,860	1,845	1,845			575	275	1,465	
	16	95.496	F _{2T} ⁽⁸⁾ (N)	39,271	39,271		39,271	38,646	38,646			17,917	6,979	29,792	
			T _{2B} ⁽⁹⁾ (Nm)	1,885	1,885		1,885	1,855	1,855			860	335	1,430	
	17	101.856	F _{2T} ⁽⁸⁾ (N)	46,176	46,176		46,176	45,784	45,784			20,294	8,039	36,471	
			T _{2B} ⁽⁹⁾ (Nm)	2,355	2,355		2,355	2,335	2,335			1,035	410	1,860	
8	13	109.856	F _{2T} ⁽⁸⁾ (N)	70,769	70,769		70,769	70,769	70,769			25,962		59,615	
			T _{2B} ⁽⁹⁾ (Nm)	3,680	3,680		3,680	3,680	3,680			1,350		3,100	

* The Maximal Driving Torque is also to be understood as the Maximal Acceleration Torque T_{2B}.

The Emergency Stop Torque T_{2NOT} = 2 × T_{2B}, under the condition limited 1000 times in the whole service period.

(1) Number of Teeth (5) Working Pitch Circle Diameter (in mm) (8) Maximum Feed-Force (9) Maximum Driving Torque

Note : The strength of screws is a limitation of the max. transmission torque. For Pinion Welded Plate, please refer to Page.40.

Pinion with Straight Teeth (Interface : Keyway)

Quality DIN 5 / Alloy Steel
Tooth Thickness Tolerance : e25
Straight Teeth
Case-Hardened and Teeth Ground

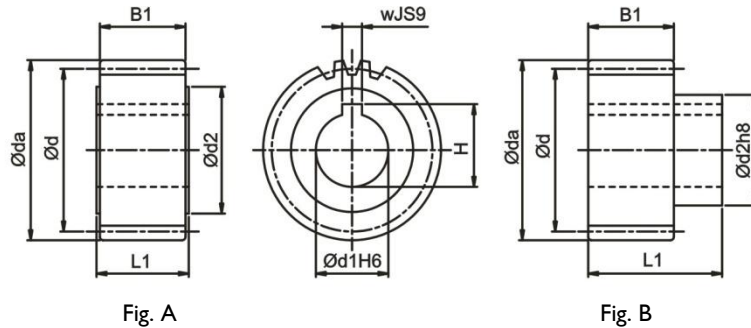

Module 1

z ⁽¹⁾	x ⁽²⁾	da ⁽³⁾	d ⁽⁴⁾	dw ⁽⁵⁾	dl _{H6}	d2	B1	L1	w _{JS9}	H	L ⁽⁶⁾	Fig	Order code	
													Pinion	Shrink disc
30	0	32	30	30	12	22	17	19	4	13.8	94.248	A	F01130A12	
30	0	32	30	30	13	22	17	19	5	15.3	94.248	A	F01130A13	

Module 1.5

z ⁽¹⁾	x ⁽²⁾	da ⁽³⁾	d ⁽⁴⁾	dw ⁽⁵⁾	dl _{H6}	d2	B1	L1	w _{JS9}	H	L ⁽⁶⁾	Fig	Order code	
													Pinion	Shrink disc
20 ⁽⁷⁾	0	33	30	30	11	25	20	22	4	12.8	94.248	A	F11120A11	
20 ⁽⁷⁾	0	33	30	30	14	25	20	22	5	16.3	94.248	A	F11120A14	
20 ⁽⁷⁾	0	33	30	30	16	25	20	22	5	18.3	94.248	A	F11120A16	

Module 2

z ⁽¹⁾	x ⁽²⁾	da ⁽³⁾	d ⁽⁴⁾	dw ⁽⁵⁾	dl _{H6}	d2	B1	L1	w _{JS9}	H	L ⁽⁶⁾	Fig	Order code	
													Pinion	Shrink disc
16	0	36	32	32	15	25	28	30	5	17.3	100.531	A	F02116A15	
18	0	40	36	36	15	28	28	30	5	17.3	113.097	A	F02118A15	
18	0	40	36	36	20	28	28	30	6	22.8	113.097	A	F02118A20	
20	0	44	40	40	15	25	28	30	5	17.3	125.664	A	F02120A15	
20	0	44	40	40	19	30	28	30	6	21.8	125.664	A	F02120A19	
20	0	44	40	40	19	30	28	56	6	21.8	125.664	B	F02120B19	SSD-30
20	0	44	40	40	20	30	28	30	6	22.8	125.664	A	F02120A20	
20	0	44	40	40	22	30	28	30	6	24.8	125.664	A	F02120A22	
20	0	44	40	40	22	36	28	56	6	24.8	125.664	B	F02120B22	SSD-36
22	0	48	44	44	15	25	28	30	5	17.3	138.23	A	F02122A15	
22	0	48	44	44	19	30	28	30	6	21.8	138.23	A	F02122A19	
22	0	48	44	44	19	30	28	56	6	21.8	138.23	B	F02122B19	SSD-30
22	0	48	44	44	20	30	28	30	6	22.8	138.23	A	F02122A20	
22	0	48	44	44	22	30	28	30	6	24.8	138.23	A	F02122A22	
22	0	48	44	44	22	36	28	56	6	24.8	138.23	B	F02122B22	SSD-36
22	0	48	44	44	25	36	28	30	8	28.3	138.23	A	F02122A25	
25	0	54	50	50	15	25	28	30	5	17.3	157.08	A	F02125A15	
25	0	54	50	50	16	30	28	54	5	18.3	157.08	B	F02125B16	SSD-30
25	0	54	50	50	19	30	28	30	6	21.8	157.08	A	F02125A19	
25	0	54	50	50	19	30	28	56	6	21.8	157.08	B	F02125B19	SSD-30
25	0	54	50	50	20	30	28	30	6	22.8	157.08	A	F02125A20	
25	0	54	50	50	22	30	28	30	6	24.8	157.08	A	F02125A22	
25	0	54	50	50	22	36	28	56	6	24.8	157.08	B	F02125B22	SSD-36
25	0	54	50	50	25	36	28	30	8	28.3	157.08	A	F02125A25	
25	0	54	50	50	30	44	28	30	8	33.3	157.08	A	F02125A30	
28	0	60	56	56	15	25	28	30	5	17.3	175.929	A	F02128A15	
28	0	60	56	56	19	30	28	30	6	21.8	175.929	A	F02128A19	
28	0	60	56	56	19	30	28	56	6	21.8	175.929	B	F02128B19	SSD-30
28	0	60	56	56	20	30	28	30	6	22.8	175.929	A	F02128A20	
28	0	60	56	56	22	30	28	30	6	24.8	175.929	A	F02128A22	
28	0	60	56	56	22	36	28	56	6	24.8	175.929	B	F02128B22	SSD-36
28	0	60	56	56	25	36	28	30	8	28.3	175.929	A	F02128A25	
28	0	60	56	56	30	45	28	30	8	33.3	175.929	A	F02128A30	
28	0	60	56	56	30	50	28	60	8	33.3	175.929	B	F02128B30	SSD-50
28	0	60	56	56	35	48	28	30	10	38.3	175.929	A	F02128A35	

(1) Number of teeth (2) Profile modification factor (3) Diameter of addendum circle (4) Pitch circle diameter
(5) Working pitch circle diameter (6) Pitch circle length $L = \pi \times d$

Pinion with Straight Teeth

(Interface : Keyway)

Quality DIN 5 / Alloy Steel
 Tooth Thickness Tolerance : e25
 Straight Teeth
 Case-Hardened and Teeth Ground

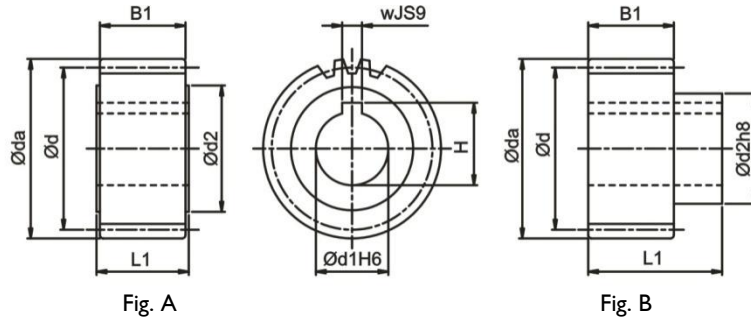

Module 2

z ⁽¹⁾	x ⁽²⁾	da ⁽³⁾	d ⁽⁴⁾	dw ⁽⁵⁾	dl H6	d2	B1	L1	w JS9	H	L ⁽⁶⁾	Fig	Order code	
													Pinion	Shrink disc
32	0	68	64	64	15	36	28	30	5	17.3	201.062	A	F02132A15	
32	0	68	64	64	16	30	28	54	5	18.3	201.062	B	F02132B16	SSD-30
32	0	68	64	64	20	30	28	30	6	22.8	201.062	A	F02132A20	
32	0	68	64	64	22	30	28	30	6	24.8	201.062	A	F02132A22	
32	0	68	64	64	22	36	28	56	6	24.8	201.062	B	F02132B22	SSD-36
32	0	68	64	64	25	36	28	30	8	28.3	201.062	A	F02132A25	
32	0	68	64	64	30	45	28	30	8	33.3	201.062	A	F02132A30	
32	0	68	64	64	30	50	28	60	8	33.3	201.062	B	F02132B30	SSD-50
32	0	68	64	64	32	55	28	65	10	35.3	201.062	B	F02132B32	SSD-55
32	0	68	64	64	35	48	28	30	10	38.3	201.062	A	F02132A35	
36	0	76	72	72	20	30	28	30	6	22.8	226.195	A	F02136A20	
36	0	76	72	72	25	36	28	30	8	28.3	226.195	A	F02136A25	
36	0	76	72	72	30	45	28	30	8	33.3	226.195	A	F02136A30	
36	0	76	72	72	35	48	28	30	10	38.3	226.195	A	F02136A35	
36	0	76	72	72	40	62	28	65	12	43.3	226.195	B	F02136B40	SSD-62
36	0	76	72	72	45	58	28	30	14	48.8	226.195	A	F02136A45	
40	0	84	80	80	15	36	28	30	5	17.3	251.327	A	F02140A15	
40	0	84	80	80	20	30	28	30	6	22.8	251.327	A	F02140A20	
40	0	84	80	80	25	36	28	30	8	28.3	251.327	A	F02140A25	
40	0	84	80	80	30	45	28	30	8	33.3	251.327	A	F02140A30	
40	0	84	80	80	32	55	28	65	10	35.3	251.327	B	F02140B32	SSD-55
40	0	84	80	80	35	48	28	30	10	38.3	251.327	A	F02140A35	
40	0	84	80	80	40	62	28	65	12	43.3	251.327	B	F02140B40	SSD-62
40	0	84	80	80	45	58	28	30	14	48.8	251.327	A	F02140A45	
40	0	84	80	80	45	68	28	65	14	48.8	251.327	B	F02140B45	SSD-68
45	0	94	90	90	20	30	28	30	6	22.8	282.743	A	F02145A20	
45	0	94	90	90	25	36	28	30	8	28.3	282.743	A	F02145A25	
45	0	94	90	90	35	48	28	30	10	38.3	282.743	A	F02145A35	
45	0	94	90	90	45	58	28	30	14	48.8	282.743	A	F02145A45	
50	0	104	100	100	20	30	28	30	6	22.8	314.159	A	F02150A20	
50	0	104	100	100	25	36	28	30	8	28.3	314.159	A	F02150A25	
50	0	104	100	100	35	48	28	30	10	38.3	314.159	A	F02150A35	
50	0	104	100	100	45	58	28	30	14	48.8	314.159	A	F02150A45	
50	0	104	100	100	45	68	28	65	14	48.8	314.159	B	F02150B45	SSD-68
56	0	116	112	112	25	36	28	30	8	28.3	351.858	A	F02156A25	
56	0	116	112	112	35	48	28	30	10	38.3	351.858	A	F02156A35	
63	0	130	126	126	25	36	28	30	8	28.3	395.841	A	F02163A25	
71	0	146	142	142	35	48	28	30	10	38.3	446.106	A	F02171A35	
80	0	164	160	160	35	48	28	30	10	38.3	502.655	A	F02180A35	
90	0	184	180	180	45	58	28	30	14	48.8	565.487	A	F02190A45	

Quality DIN 5 / Alloy Steel
 Tooth Thickness Tolerance : e25
 Straight Teeth
 Case-Hardened and Teeth Ground

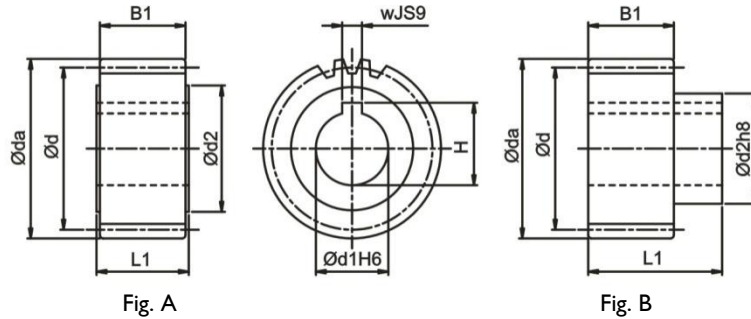

Module 3

z ⁽¹⁾	x ⁽²⁾	da ⁽³⁾	d ⁽⁴⁾	dw ⁽⁵⁾	d1 H6	d2	B1	L1	w JS9	H	L ⁽⁶⁾	Fig	Order code	
													Pinion	Shrink disc
18	0	60	54	54	25	36	28	30	8	28.3	169.646	A	F03118A25	
20	0	66	60	60	25	36	28	30	8	28.3	188.496	A	F03120A25	
20	0	66	60	60	30	45	28	30	8	33.3	188.496	A	F03120A30	
20	0	66	60	60	35	48	28	30	10	38.3	188.496	A	F03120A35	
22	0	72	66	66	22	36	28	56	6	24.8	207.345	B	F03122B22	SSD-36
22	0	72	66	66	25	36	28	30	8	28.3	207.345	A	F03122A25	
22	0	72	66	66	25	44	28	60	8	28.3	207.345	B	F03122B25	SSD-44
22	0	72	66	66	30	45	28	30	8	33.3	207.345	A	F03122A30	
22	0	72	66	66	30	50	28	60	8	33.3	207.345	B	F03122B30	SSD-50
22	0	72	66	66	32	55	28	65	10	35.3	207.345	B	F03122B32	SSD-55
22	0	72	66	66	35	48	28	30	10	38.3	207.345	A	F03122A35	
22	0	72	66	66	35	55	28	65	10	38.3	207.345	B	F03122B35	SSD-55
22	0	72	66	66	40	62	28	65	12	43.3	207.345	B	F03122B40	SSD-62
25	0	81	75	75	25	36	28	30	8	28.3	235.619	A	F03125A25	
25	0	81	75	75	30	45	28	30	8	33.3	235.619	A	F03125A30	
25	0	81	75	75	32	55	28	65	10	35.3	235.619	B	F03125B32	SSD-55
25	0	81	75	75	35	48	28	30	10	38.3	235.619	A	F03125A35	
25	0	81	75	75	40	62	28	65	12	43.3	235.619	B	F03125B40	SSD-62
25	0	81	75	75	45	58	28	30	14	48.8	235.619	A	F03125A45	
28	0	90	84	84	22	36	28	56	6	24.8	263.894	B	F03128B22	SSD-36
28	0	90	84	84	25	36	28	30	8	28.3	263.894	A	F03128A25	
28	0	90	84	84	25	44	28	60	8	28.3	263.894	B	F03128B25	SSD-44
28	0	90	84	84	30	45	28	30	8	33.3	263.894	A	F03128A30	
28	0	90	84	84	30	50	28	60	8	33.3	263.894	B	F03128B30	SSD-50
28	0	90	84	84	32	55	28	65	10	35.3	263.894	B	F03128B32	SSD-55
28	0	90	84	84	35	48	28	30	10	38.3	263.894	A	F03128A35	
28	0	90	84	84	35	55	28	65	10	38.3	263.894	B	F03128B35	SSD-55
28	0	90	84	84	40	62	28	65	12	43.3	263.894	B	F03128B40	SSD-62
28	0	90	84	84	45	58	28	30	14	48.8	263.894	A	F03128A45	
28	0	90	84	84	45	68	28	65	14	48.8	263.894	B	F03128B45	SSD-68

(1) Number of teeth (2) Profile modification factor (3) Diameter of addendum circle (4) Pitch circle diameter
 (5) Working pitch circle diameter (6) Pitch circle length $L = \pi \times d$

Pinion with Straight Teeth (Interface : Keyway)

Quality DIN 5 / Alloy Steel
Tooth Thickness Tolerance : e25
Straight Teeth
Case-Hardened and Teeth Ground

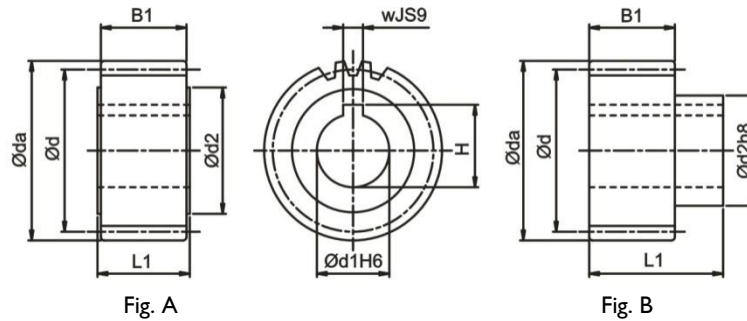

Module 3

z ⁽¹⁾	x ⁽²⁾	da ⁽³⁾	d ⁽⁴⁾	dw ⁽⁵⁾	dl H6	d2	Bl	Ll	w JS9	H	L ⁽⁶⁾	Fig	Order code	
													Pinion	Shrink disc
32	0	102	96	96	25	36	28	30	8	28.3	301.593	A	F03132A25	
32	0	102	96	96	30	45	28	30	8	33.3	301.593	A	F03132A30	
32	0	102	96	96	32	55	28	65	10	35.3	301.593	B	F03132B32	SSD-55
32	0	102	96	96	35	48	28	30	10	38.3	301.593	A	F03132A35	
32	0	102	96	96	40	62	28	65	12	43.3	301.593	B	F03132B40	SSD-62
32	0	102	96	96	45	58	28	30	14	48.8	301.593	A	F03132A45	
32	0	102	96	96	60	80	28	30	18	64.4	301.593	A	F03132A60	
36	0	114	108	108	25	36	28	30	8	28.3	339.292	A	F03136A25	
36	0	114	108	108	35	48	28	30	10	38.3	339.292	A	F03136A35	
36	0	114	108	108	45	58	28	30	14	48.8	339.292	A	F03136A45	
36	0	114	108	108	45	68	28	65	14	48.8	339.292	B	F03136B45	SSD-68
36	0	114	108	108	60	80	28	30	18	64.4	339.292	A	F03136A60	
40	0	126	120	120	25	36	28	30	8	28.3	376.991	A	F03140A25	
40	0	126	120	120	35	48	28	30	10	38.3	376.991	A	F03140A35	
40	0	126	120	120	45	58	28	30	14	48.8	376.991	A	F03140A45	
40	0	126	120	120	60	80	28	30	18	64.4	376.991	A	F03140A60	
45	0	141	135	135	25	36	28	30	8	28.3	424.115	A	F03145A25	
45	0	141	135	135	35	48	28	30	10	38.3	424.115	A	F03145A35	
45	0	141	135	135	45	58	28	30	14	48.8	424.115	A	F03145A45	
45	0	141	135	135	60	80	28	30	18	64.4	424.115	A	F03145A60	
50	0	156	150	150	35	48	28	30	10	38.3	471.239	A	F03150A35	
50	0	156	150	150	45	58	28	30	14	48.8	471.239	A	F03150A45	
56	0	174	168	168	45	58	28	30	14	48.8	527.788	A	F03156A45	
63	0	195	189	189	45	58	28	30	14	48.8	593.761	A	F03163A45	
63	0	195	189	189	60	80	28	30	18	64.4	593.761	A	F03163A60	

Quality DIN 5 / Alloy Steel
 Tooth Thickness Tolerance : e25
 Straight Teeth
 Case-Hardened and Teeth Ground

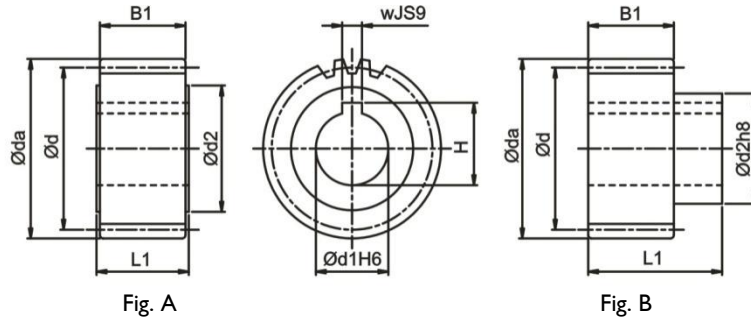

Module 4

z ⁽¹⁾	x ⁽²⁾	da ⁽³⁾	d ⁽⁴⁾	dw ⁽⁵⁾	d1 H ₆	d2	B1	L1	w _{JS9}	H	L ⁽⁶⁾	Fig	Order code	
													Pinion	Shrink disc
20	0	88	80	80	32	55	40	75	10	35.3	251.327	B	F04120B32	SSD-55
20	0	88	80	80	35	52	40	50	10	38.3	251.327	A	F04120A35	
20	0	88	80	80	35	55	40	75	10	38.3	251.327	B	F04120B35	SSD-55
20	0	88	80	80	40	62	40	75	12	43.3	251.327	B	F04120B40	SSD-62
20	0	88	80	80	45	65	40	50	14	48.8	251.327	A	F04120A45	
22	0	96	88	88	35	52	40	50	10	38.3	276.46	A	F04122A35	
22	0	96	88	88	45	65	40	50	14	48.8	276.46	A	F04122A45	
22	0	96	88	88	45	68	40	75	14	48.8	276.46	B	F04122B45	SSD-68
25	0	108	100	100	32	55	40	75	10	35.3	314.159	B	F04125B32	SSD-55
25	0	108	100	100	35	52	40	50	10	38.3	314.159	A	F04125A35	
25	0	108	100	100	35	55	40	75	10	38.3	314.159	B	F04125B35	SSD-55
25	0	108	100	100	40	62	40	75	12	43.3	314.159	B	F04125B40	SSD-62
25	0	108	100	100	45	65	40	50	14	48.8	314.159	A	F04125A45	
25	0	108	100	100	55	80	40	80	16	59.3	314.159	B	F04125B55	SSD-80
28	0	120	112	112	35	52	40	50	10	38.3	351.858	A	F04128A35	
28	0	120	112	112	45	65	40	50	14	48.8	351.858	A	F04128A45	
28	0	120	112	112	45	68	40	75	14	48.8	351.858	B	F04128B45	SSD-68
32	0	136	128	128	35	52	40	50	10	38.3	402.124	A	F04132A35	
32	0	136	128	128	45	65	40	50	14	48.8	402.124	A	F04132A45	
32	0	136	128	128	55	80	40	80	16	59.3	402.124	B	F04132B55	SSD-80
32	0	136	128	128	75	110	40	100	20	79.9	402.124	B	F04132B75	SSD-110
40	0	168	160	160	45	65	40	50	14	48.8	502.655	A	F04140A45	
40	0	168	160	160	60	80	40	50	18	64.4	502.655	A	F04140A60	
40	0	168	160	160	75	110	40	100	20	79.9	502.655	B	F04140B75	SSD-110

Module 5

z ⁽¹⁾	x ⁽²⁾	da ⁽³⁾	d ⁽⁴⁾	dw ⁽⁵⁾	d1 H ₆	d2	B1	L1	w _{JS9}	H	L ⁽⁶⁾	Fig	Order code	
													Pinion	Shrink disc
21	0	115	105	105	45	68	50	85	14	48.8	329.867	B	F05121B45	SSD-68
21	0	115	105	105	55	80	50	90	16	59.3	329.867	B	F05121B55	SSD-80
25	0	135	125	125	45	68	50	85	14	48.8	392.699	B	F05125B45	SSD-68
25	0	135	125	125	55	80	50	90	16	59.3	392.699	B	F05125B55	SSD-80
25	0	135	125	125	75	110	50	110	20	79.9	392.699	B	F05125B75	SSD-110

(1) Number of teeth (2) Profile modification factor (3) Diameter of addendum circle (4) Pitch circle diameter
 (5) Working pitch circle diameter (6) Pitch circle length $L = \pi \times d$

Pinion with Straight Teeth

(Interface : Keyway)

Quality DIN 5 / Alloy Steel
 Tooth Thickness Tolerance : e25 **
 Straight Teeth
 Case-Hardened and Teeth Ground

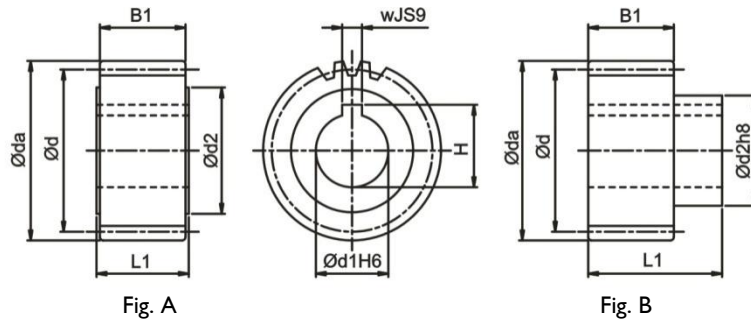

Module 6

z ⁽¹⁾	x ⁽²⁾	da ⁽³⁾	d ⁽⁴⁾	dw ⁽⁵⁾	d1 H6	d2	B1	L1	w JS9	H	L ⁽⁶⁾	Fig	Order code	
													Pinion	Shrink disc
21	0	138	126	126	55	80	60	100	16	59.3	395.841	B	F06121B55	SSD-80
21	0	138	126	126	75	110	60	120	20	79.9	395.841	B	F06121B75	SSD-110
25	0	162	150	150	55	80	60	100	16	59.3	471.239	B	F06125B55	SSD-80
25	0	162	150	150	75	110	60	120	20	79.9	471.239	B	F06125B75	SSD-110

Module 8

z ⁽¹⁾	x ⁽²⁾	da ⁽³⁾	d ⁽⁴⁾	dw ⁽⁵⁾	d1 H6	d2	B1	L1	w JS9	H	L ⁽⁶⁾	Fig	Order code	
													Pinion	Shrink disc
20	0	176	160	160	75	110	80	140	20	79.9	502.655	B	F08120B75	SSD-110
20	0	176	160	160	85	125	80	145	22	90.4	502.655	B	F08120B85	SSD-125

Module 10

z ⁽¹⁾	x ⁽²⁾	da ⁽³⁾	d ⁽⁴⁾	dw ⁽⁵⁾	d1 H6	d2	B1	L1	w JS9	H	L ⁽⁶⁾	Fig	Order code	
													Pinion	Shrink disc
20	0	220	200	200	85	125	100	165	22	90.4	628.319	B	F10120B85	SSD-125

** By Module 8 or 10, the Tooth Thickness Tolerance = f 23.

- (1) Number of teeth (2) Profile modification factor (3) Diameter of addendum circle
 (4) Pitch circle diameter (5) Working pitch circle diameter (6) Pitch circle length $L = \pi \times d$

Pinion material carburized, the surface hardness reached 60 HRc
 Teeth surface ground in order to reduce noise and improve wear resistance
 Accessories include hexagon socket head cap screws (Strength 12.9 , DIN 912)

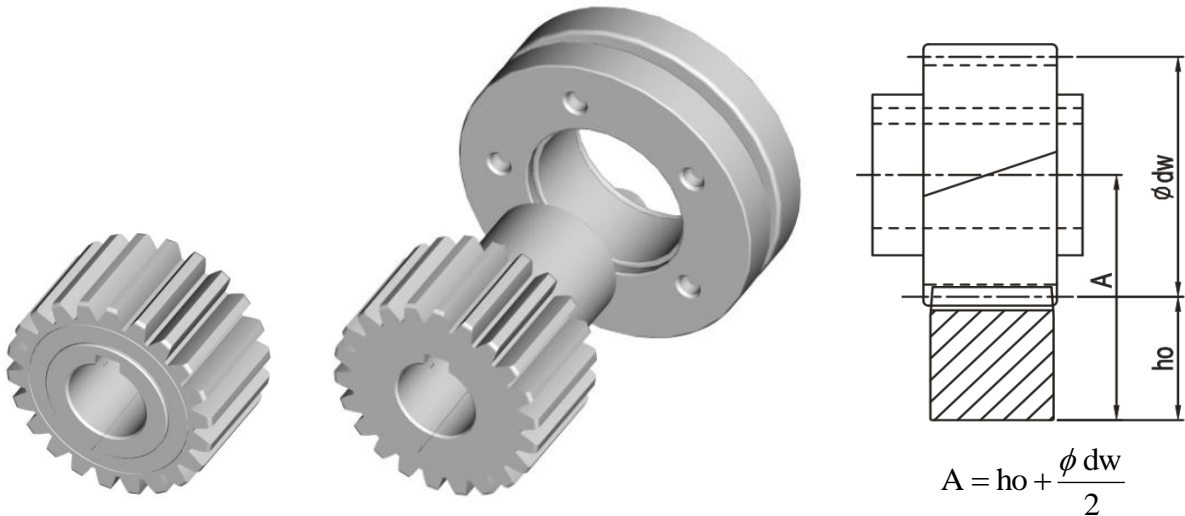

In Table I I, the maximum permissible torque of pinion with Keyway, and the rack is calculated on the basis of a speed of 1.5 m/s and providing good lubrication (using an automatic lubrication system or manually applied grease every day), the tooth root strength factor $S_F \geq 1.4$, tooth surface strength coefficient $S_H \geq 1$, the safety factor $S_B \cong 1$, and the required service life of 20,000 hours. By higher speed, the max. permissible torque reduced. The user needs to increase the safety factor for the application. Backlash changes by different center height. Please contact APEX under WWW.APEXDYNA.COM.

Pinion with Straight Teeth

(Interface : Keyway)

Table II. The max. permitted torque and feed-force of pinion with Keyway

Pinion \ Rack			Quality	Q4	Q5H	Q5		Q6	Q6M	Q6C	Q8H	Q8	Q9	Q10
			Material	Carbon Steel	Alloy Steel		Carbon Steel	Carbon Steel	Carbon Steel	Carbon Steel	Q&T Alloy Steel	Carbon Steel	Stainless Steel	Carbon Steel
			Heat Treatment	Induction Hardening	Case Hardening	Carburized Induction	Induction Hardening	Induction Hardening	Induction Hardening	Normalizing	Quenched Tempered	Normalizing	Solution	Induction Hardening
Mn	z ⁽¹⁾	dw ⁽⁵⁾	Max. Torque * and Feed-Force											
1	30	30	F _{2T} ⁽⁸⁾ (N)				2,000		667		333	333	667	
			T _{2B} ⁽⁹⁾ (Nm)				30		10		5	5	10	
1.5	20	30	F _{2T} ⁽⁸⁾ (N)								667		1,333	
			T _{2B} ⁽⁹⁾ (Nm)								10		20	
2	16	32	F _{2T} ⁽⁸⁾ (N)		4,375	4,375		4,375	4,375	1,563	1,875	1,250	625	1,563
			T _{2B} ⁽⁹⁾ (Nm)		70	70		70	70	25	30	20	10	25
	18	36	F _{2T} ⁽⁸⁾ (N)		5,556	5,556		5,556	5,556	1,667	1,944	1,389	556	1,944
			T _{2B} ⁽⁹⁾ (Nm)		100	100		100	100	30	35	25	10	35
	20	40	F _{2T} ⁽⁸⁾ (N)		5,250	5,250		7,000	7,000	1,250	1,500	1,000	500	2,250
			T _{2B} ⁽⁹⁾ (Nm)		105	105		140	140	25	30	20	10	45
	22	44	F _{2T} ⁽⁸⁾ (N)		8,182	8,182		7,045	7,045	1,364	1,591	1,136	682	2,273
			T _{2B} ⁽⁹⁾ (Nm)		180	180		155	155	30	35	25	15	50
	25	50	F _{2T} ⁽⁸⁾ (N)		8,400	8,400		7,200	7,200	1,600	2,000	1,200	800	2,200
			T _{2B} ⁽⁹⁾ (Nm)		210	210		180	180	40	50	30	20	55
	28	56	F _{2T} ⁽⁸⁾ (N)		8,571	8,571		7,143	7,143	1,786	2,143	1,429	714	2,321
			T _{2B} ⁽⁹⁾ (Nm)		240	240		200	200	50	60	40	20	65
	32	64	F _{2T} ⁽⁸⁾ (N)		8750	8750		7,188	7,188	2,188	2,656	1,719	781	2,188
			T _{2B} ⁽⁹⁾ (Nm)		280	280		230	230	70	85	55	25	70
	36	72	F _{2T} ⁽⁸⁾ (N)		8,611	8,611		7,222	7,222	2,778	3,472	2,083	694	2,222
			T _{2B} ⁽⁹⁾ (Nm)		310	310		260	260	100	125	75	25	80
	40	80	F _{2T} ⁽⁸⁾ (N)		8,750	8,750		7,125	7,125	3,625	3,375	2,250	750	2,125
			T _{2B} ⁽⁹⁾ (Nm)		350	350		285	285	145	135	90	30	85
	45	90	F _{2T} ⁽⁸⁾ (N)		8,667	8,667		7,111	7,111	3,667	3,333	2,333	667	2,111
			T _{2B} ⁽⁹⁾ (Nm)		390	390		320	320	165	150	105	30	95
	50	100	F _{2T} ⁽⁸⁾ (N)		8,700	8,700		7,000	7,000	3,600	3,200	2,300	700	2,100
			T _{2B} ⁽⁹⁾ (Nm)		435	435		350	350	180	160	115	35	105
	56	112	F _{2T} ⁽⁸⁾ (N)		8,750	8,750		6,964	6,964	3,571	3,214	2,321	714	2,054
			T _{2B} ⁽⁹⁾ (Nm)		490	490		390	390	200	180	130	40	115
	63	126	F _{2T} ⁽⁸⁾ (N)		8,889	8,889		6,825	6,825	3,413	3,016	2,222	714	2,063
			T _{2B} ⁽⁹⁾ (Nm)		560	560		430	430	215	190	140	45	130
	71	142	F _{2T} ⁽⁸⁾ (N)		9,085	9,085		6,901	6,901	3,592	3,169	2,254	704	2,042
			T _{2B} ⁽⁹⁾ (Nm)		645	645		490	490	255	225	160	50	145
80	160	F _{2T} ⁽⁸⁾ (N)		9,313	9,313		7,000	7,000	3,688	3,250	2,313	750	2,063	
		T _{2B} ⁽⁹⁾ (Nm)		745	745		560	560	295	260	185	60	165	
90	180	F _{2T} ⁽⁸⁾ (N)		9,444	9,444		7,167	7,167	3,833	3,389	2,333	722	2,056	
		T _{2B} ⁽⁹⁾ (Nm)		850	850		645	645	345	305	210	65	185	
3	18	54	F _{2T} ⁽⁸⁾ (N)		11,481	11,481		11,111	11,111	3,519	4,630	2,222	1,296	3,704
			T _{2B} ⁽⁹⁾ (Nm)		310	310		300	300	95	125	60	35	100
	20	60	F _{2T} ⁽⁸⁾ (N)		13,667	13,667		13,333	13,333	2,333	2,833	1,833	1,000	5,167
			T _{2B} ⁽⁹⁾ (Nm)		410	410		400	400	70	85	55	30	155
	22	66	F _{2T} ⁽⁸⁾ (N)		15,152	15,152		13,636	13,636	2,727	3,333	1,970	1,061	6,667
			T _{2B} ⁽⁹⁾ (Nm)		500	500		450	450	90	110	65	35	220
	25	75	F _{2T} ⁽⁸⁾ (N)		15,600	15,600		13,600	13,600	3,733	4,800	2,400	1,333	6,667
			T _{2B} ⁽⁹⁾ (Nm)		585	585		510	510	140	180	90	50	250

* The Maximal Driving Torque is also to be understood as the Maximal Acceleration Torque T_{2B}.

The Emergency Stop Torque T_{2NOT} = 2 × T_{2B}, under the condition limited 1000 times in the whole service period.

(1) Number of Teeth (5) Working Pitch Circle Diameter (in mm) (8) Maximum Feed-Force (9) Maximum Driving Torque

Table II. The max. permitted torque and feed-force of pinion with Keyway

Pinion			Rack		Quality	Q4	Q5H	Q5		Q6	Q6M	Q6C	Q8H	Q8	Q9	Q10	
			Material		Carbon Steel	Alloy Steel		Carbon Steel	Carbon Steel	Carbon Steel	Carbon Steel	Carbon Steel	Carbon Steel	Q&T Alloy Steel	Carbon Steel	Stainless Steel	Carbon Steel
			Heat Treatment		Induction Hardening	Case Hardening	Carburized Induction	Induction Hardening	Induction Hardening	Induction Hardening	Normalizing	Quenched Tempered	Normalizing	Solution	Induction Hardening		
Mn	z ⁽¹⁾	dw ⁽⁵⁾	Max. Torque * and Feed-Force														
3	28	84	F _{2T} ⁽⁸⁾ (N)		15,833	15,833		13,690	13,690	4,762	6,310	2,738	1,429	6,429			
			T _{2B} ⁽⁹⁾ (Nm)		665	665		575	575	200	265	115	60	270			
	32	96	F _{2T} ⁽⁸⁾ (N)		16,146	16,146		13,646	13,646	6,250	8,438	3,542	1,354	6,146			
			T _{2B} ⁽⁹⁾ (Nm)		775	775		655	655	300	405	170	65	295			
	36	108	F _{2T} ⁽⁸⁾ (N)		16,389	16,389		13,704	13,704	7,685	8,981	4,722	1,389	5,833			
			T _{2B} ⁽⁹⁾ (Nm)		885	885		740	740	415	485	255	75	315			
	40	120	F _{2T} ⁽⁸⁾ (N)		16,500	16,500		13,833	13,833	8,250	9,000	6,167	1,333	5,833			
			T _{2B} ⁽⁹⁾ (Nm)		990	990		830	830	495	540	370	80	350			
	45	135	F _{2T} ⁽⁸⁾ (N)		16,593	16,593		14,148	14,148	8,519	9,259	6,667	1,333	5,852			
			T _{2B} ⁽⁹⁾ (Nm)		1,120	1,120		955	955	575	625	450	90	395			
	50	150	F _{2T} ⁽⁸⁾ (N)		16,733	16,733		14,400	14,400	8,667	9,533	6,800	1,400	5,933			
			T _{2B} ⁽⁹⁾ (Nm)		1,255	1,255		1,080	1,080	650	715	510	105	445			
	56	168	F _{2T} ⁽⁸⁾ (N)		16,786	16,786		14,643	14,643	8,869	9,762	6,964	1,369	6,012			
			T _{2B} ⁽⁹⁾ (Nm)		1,410	1,410		1,230	1,230	745	820	585	115	505			
63	189	F _{2T} ⁽⁸⁾ (N)		16,825	16,825		14,974	14,974	9,101	10,053	7,196	1,429	6,085				
		T _{2B} ⁽⁹⁾ (Nm)		1,590	1,590		1,415	1,415	860	950	680	135	575				
4	20	80	F _{2T} ⁽⁸⁾ (N)		26,125		25,000	24,625	24,625	5,375	7,125	3,625	1,750	1,1875			
			T _{2B} ⁽⁹⁾ (Nm)		1,045		1,000	985	985	215	285	145	70	475			
	22	88	F _{2T} ⁽⁸⁾ (N)		29,091		25,114	24,659	24,659	6,818	8,864	4,091	2,045	11,932			
			T _{2B} ⁽⁹⁾ (Nm)		1,280		1,105	1,085	1,085	300	390	180	90	525			
	25	100	F _{2T} ⁽⁸⁾ (N)		29,300		25,200	24,800	24,800	8,900	11,900	5,300	2,200	11,300			
			T _{2B} ⁽⁹⁾ (Nm)		1,465		1,260	1,240	1,240	445	595	265	110	565			
	28	112	F _{2T} ⁽⁸⁾ (N)		29,375		25,268	24,821	24,821	10,982	15,089	6,518	2,143	11,161			
			T _{2B} ⁽⁹⁾ (Nm)		1,645		1,415	1,390	1,390	615	845	365	120	625			
	32	128	F _{2T} ⁽⁸⁾ (N)		30,000		25,781	25,391	25,391	13,750	16,953	8,594	2,188	11,250			
			T _{2B} ⁽⁹⁾ (Nm)		1,920		1,650	1,625	1,625	880	1,085	550	140	720			
	40	160	F _{2T} ⁽⁸⁾ (N)		31,188		26,813	26,438	26,438	16,375	17,813	12,438	2,250	11,563			
			T _{2B} ⁽⁹⁾ (Nm)		2,495		2,145	2,115	2,115	1,310	1,425	995	180	925			
	5	21	105	F _{2T} ⁽⁸⁾ (N)	39,333	44,762		39,333	39,048	39,048			17,813	3,238	23,714		
				T _{2B} ⁽⁹⁾ (Nm)	2,065	2,350		2,065	2,050	2,050			390	170	1,245		
25		125	F _{2T} ⁽⁸⁾ (N)	40,160	46,640		40,160	39,760	39,760			10,640	3,440	23,280			
			T _{2B} ⁽⁹⁾ (Nm)	2,510	2,915		2,510	2,485	2,485			665	215	1,455			
6	21	126	F _{2T} ⁽⁸⁾ (N)	57,143	64,206		57,143	57,143	57,143			13,651	4,921	40,794			
			T _{2B} ⁽⁹⁾ (Nm)	3,600	4,045		3,600	3,600	3,600			860	310	2,570			
	25	150	F _{2T} ⁽⁸⁾ (N)	59,133	66,533		59,133	59,067	59,067			20,067	5,200	41,333			
			T _{2B} ⁽⁹⁾ (Nm)	4,435	4,990		4,435	4,430	4,430			1,505	390	3,100			
8	20	160	F _{2T} ⁽⁸⁾ (N)	103,750	110,250		103,750	103,750	103,750			27,938		81,250			
			T _{2B} ⁽⁹⁾ (Nm)	8,300	8,820		8,300	8,300	8,300			2,235		6,500			
10	20	200	F _{2T} ⁽⁸⁾ (N)	165,400	169,200		165,400	165,300				55,850		145,200			
			T _{2B} ⁽⁹⁾ (Nm)	16,540	16,920		16,540	16,530				5,585		14,520			

* The Maximal Driving Torque is also to be understood as the Maximal Acceleration Torque T_{2B}.

The Emergency Stop Torque T_{2NOT} = 2 x T_{2B}, under the condition limited 1000 times in the whole service period.

(1) Number of Teeth (5) Working Pitch Circle Diameter (in mm) (8) Maximum Feed-Force (9) Maximum Driving Torque

Pinion with Straight Teeth

(Interface : Keyway / CP System)

Quality DIN 5 / Alloy Steel
 Tooth Thickness Tolerance : e25
 Straight Teeth
 Case-Hardened and Teeth Ground

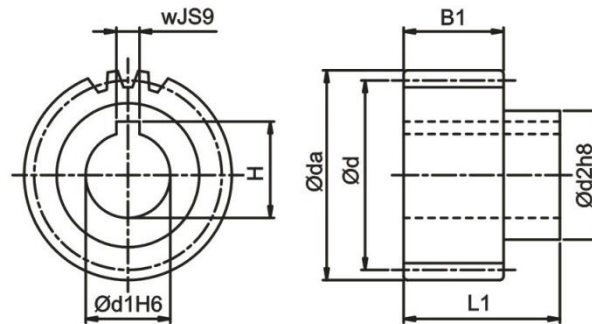

Pitch 5 (Module : 1.591)

z ⁽¹⁾	x ⁽²⁾	da ⁽³⁾	d ⁽⁴⁾	dw ⁽⁵⁾	d1 H6	d2	B1	L1	w JS9	H	L ⁽⁶⁾	Order code	
												Pinion	Shrink disc
25	0	42.971	39.788	39.788	16	30	25	51	5	18.3	124.996	FIK125B16	SSD-30
30	0	50.928	47.745	47.745	22	36	25	54	6	24.8	149.995	FIK130B22	SSD-36
40	0	66.843	63.66	63.66	25	44	25	56	8	28.3	199.994	FIK140B25	SSD-44

Pitch 10 (Module : 3.183)

z ⁽¹⁾	x ⁽²⁾	da ⁽³⁾	d ⁽⁴⁾	dw ⁽⁵⁾	d1 H6	d2	B1	L1	w JS9	H	L ⁽⁶⁾	Order code	
												Pinion	Shrink disc
20	0	70.028	63.661	63.662	22	36	31	60	6	24.8	200	F3B120B22	SSD-36
25	0	85.944	79.578	79.578	25	44	31	62	8	28.3	250	F3B125B25	SSD-44
25	0	85.944	79.578	79.578	32	55	31	68	10	35.3	250	F3B125B32	SSD-55

Pitch 13.33 (Module : 4.244)

z ⁽¹⁾	x ⁽²⁾	da ⁽³⁾	d ⁽⁴⁾	dw ⁽⁵⁾	d1 H6	d2	B1	L1	w JS9	H	L ⁽⁶⁾	Order code	
												Pinion	Shrink disc
20	0	93.368	84.88	84.88	32	55	40	77	10	35.3	266.658	F4D120B32	SSD-55
25	0	114.588	106.1	106.1	40	62	40	77	12	43.3	333.323	F4D125B40	SSD-62

(1) Number of teeth (2) Profile modification factor (3) Diameter of addendum circle (4) Pitch circle diameter
 (5) Working pitch circle diameter (6) Pitch circle length $L = \pi \times d$

Pinion material carburized, the surface hardness reached 60 HRC
 Teeth surface ground in order to reduce noise and improve wear resistance
 Accessories include hexagon socket head cap screws (Strength 12.9 · DIN 912)

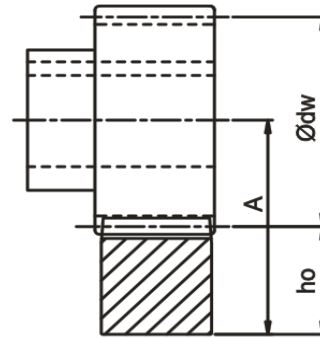
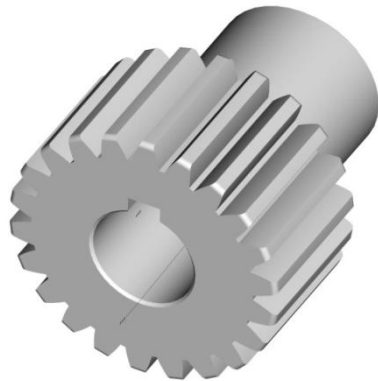

$$A = h_o + \frac{\phi dw}{2}$$

In Table 12, the maximum permissible torque of CP pinion, and the rack is calculated on the basis of a speed of 1.5 m/s and providing good lubrication (using an automatic lubrication system or manually applied grease every day), the tooth root strength factor $S_F \geq 1.4$, tooth surface strength coefficient $S_H \geq 1$, the safety factor $S_B \cong 1$, and the required service life of 20,000 hours. By higher speed, the max. permissible torque reduced. The user needs to increase the safety factor for the application. Backlash changes by different center height. Please contact APEX under WWW.APEXDYNA.COM.

Table 12. The max. permitted torque and feed-force of CP pinion with Keyway

Rack \ Pinion			Teeth Width (in mm)	Quality	Q6	Q8
				Material	Carbon Steel	Carbon Steel
Pitch $z^{(1)}$ $dw^{(5)}$				Heat Treatment	Induction Hardening	Normalizing
				Max. Torque and Feed-Force		
5	25	39.788	19 (Q6)	$F_{2T}^{(8)}$ (N)	4,524	754
			20 (Q8)	$T_{2B}^{(9)}$ (Nm)	90	15
			24 (Q6)	$F_{2T}^{(8)}$ (N)	5,781	1,005
			25 (Q8)	$T_{2B}^{(9)}$ (Nm)	115	20
	30	47.745	19 (Q6)	$F_{2T}^{(8)}$ (N)	4,398	1,047
			20 (Q8)	$T_{2B}^{(9)}$ (Nm)	105	25
			24 (Q6)	$F_{2T}^{(8)}$ (N)	5,864	1,257
			25 (Q8)	$T_{2B}^{(9)}$ (Nm)	140	30
	40	63.66	19 (Q6)	$F_{2T}^{(8)}$ (N)	4,398	1,414
			20 (Q8)	$T_{2B}^{(9)}$ (Nm)	140	45
			24 (Q6)	$F_{2T}^{(8)}$ (N)	5,655	1,728
			25 (Q8)	$T_{2B}^{(9)}$ (Nm)	180	55
10	20	63.662	29 (Q6)	$F_{2T}^{(8)}$ (N)	14,451	2,042
			30 (Q8)	$T_{2B}^{(9)}$ (Nm)	460	65
	25	79.578	29 (Q6)	$F_{2T}^{(8)}$ (N)	14,451	2,765
			30 (Q8)	$T_{2B}^{(9)}$ (Nm)	575	110
13.33	20	84.88	39 (Q6)	$F_{2T}^{(8)}$ (N)	26,272	4,123
			40 (Q8)	$T_{2B}^{(9)}$ (Nm)	1,115	175
	25	106.1	39 (Q6)	$F_{2T}^{(8)}$ (N)	26,390	6,221
			40 (Q8)	$T_{2B}^{(9)}$ (Nm)	1,400	330

* The Maximal Driving Torque is also to be understood as the Maximal Acceleration Torque T_{2B} .

The Emergency Stop Torque $T_{2NOT} = 2 \times T_{2B}$, under the condition limited 1000 times in the whole service period.

(1) Number of Teeth (5) Working Pitch Circle Diameter (in mm) (8) Maximum Feed-Force (9) Maximum Driving Torque

Pinion with Straight Teeth

(Interface : Long Shaft Pinion with Keyway for Hollow-Shaft)

Quality DIN 5

Tooth Thickness Tolerance : e25

Straight Teeth

Case-Hardened and Teeth Ground

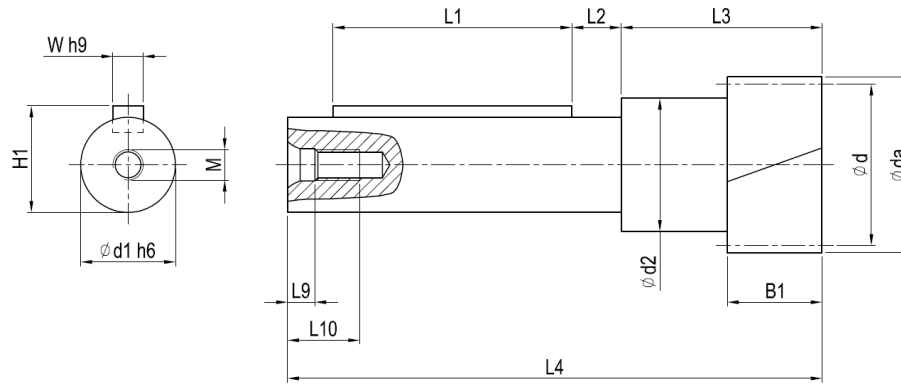

Mn.	z ⁽¹⁾	x ⁽²⁾	da ⁽³⁾	d ⁽⁴⁾	dw ⁽⁵⁾	d1 h ₆	d2	B1	L1	L2	L3	L4	M	L9	L10	W _{h9}	H1	L ⁽⁶⁾	Order Code
2	15	0.36	35.5	30	31.5	20	24	25	28	13.5	50.0	105	M5	4.8	12.5	6	22.5	94.25	G02115D20
	21	0.00	46	42	42	25	35	25	63	13.0	53.0	141	M8	7.2	19	8	28	131.95	G02121D25
	32	0.00	68	64	64	25	38	25	63	13.0	53.0	141	M8	7.2	19	8	28	201.06	G02132D25
	32	0.00	68	64	64	28	42	25	80	14.5	57.5	166	M8	7.2	19	8	31	201.06	G02132D28
	32	0.00	68	64	64	36	48	25	100	12.5	57.0	181	M12	10	28	10	39	201.06	G02132D36
3	21	0.00	69	63	63	25	38	30	63	13.0	55.0	143	M8	7.2	19	8	28	197.92	G03121D25
	21	0.00	69	63	63	28	42	30	80	14.5	60.0	168	M8	7.2	19	8	31	197.92	G03121D28
	21	0.00	69	63	63	36	48	30	100	12.5	62.0	186	M12	10	28	10	39	197.92	G03121D36
4	17	0.00	76	68	68	28	42	40	80	14.5	65.0	173	M8	7.2	19	8	31	213.63	G04117D28
	17	0.00	76	68	68	36	48	40	100	12.5	67.0	191	M12	10	28	10	39	213.63	G04117D36
	17	0.00	76	68	68	48	57	40	125	9.0	72.0	216	M12	10	28	14	51.5	213.63	G04117D48
	30	0.00	128	120	120	48	57	40	125	9.0	72.0	216	M12	10	28	14	51.5	376.99	G04130D48
5	13	0.50	80	65	70	48	57	50	125	9.0	82.0	226	M12	10	28	14	51.5	204.20	G05113D48
	15	0.50	90	75	80	60	68	50	150	10.0	90.0	272	M16	12	36	18	64	235.62	G05115D60
6	13	0.50	96	78	84	60	68	60	150	10.0	100.0	282	M16	12	36	18	64	245.04	G06113D60

- (1) Number of teeth (2) Profile modification factor (3) Diameter of addendum circle (4) Pitch circle diameter
 (5) Working pitch circle diameter (6) Pitch circle length $L = \pi \times d$

Pinion with Straight Teeth

(Interface : Long Shaft Pinion with Keyway for Hollow-Shaft)

Quality DIN 5
Tooth Thickness Tolerance : e25
Straight Teeth
Case-Hardened and Teeth Ground

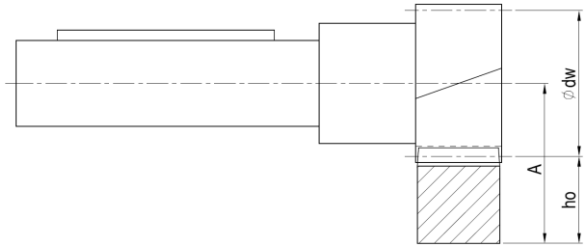
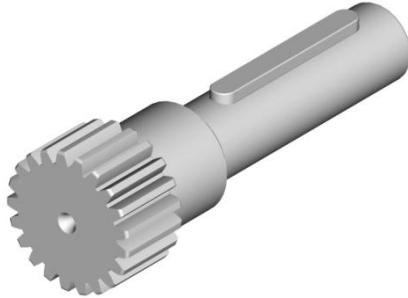

$$A = h_o + \frac{\phi \, dw}{2}$$

In table 13, the maximum permissible torque of pinion with Long Shaft w. KW for APEX AF-/PII-Gearbox, and the rack is calculated on the basis of a speed of 1.5 m/s and providing good lubrication (using an automatic lubrication system or manually applied grease every day), the tooth root strength factor $S_f \geq 1.4$, tooth surface strength coefficient $S_H \geq 1$, the safety factor $S_B \approx 1$, and the required service life of 20,000 hours. By higher speed, the max. permissible torque reduced. The user needs to increase the safety factor for the application. Backlash changes by different center height. Please contact APEX under WWW.APEXDYNA.COM.

Table 13, the max. permitted torque and feed-force of pinion with Long Shaft w. KW for APEX AF-/ PII-Series

Pinion			Rack											
			Quality	Q4	Q5H	Q5		Q6	Q6M	Q6C	Q8H	Q8	Q9	Q10
			Material	Carbon Steel	Alloy Steel		Carbon Steel	Carbon Steel	Carbon Steel	Carbon Steel	Carbon Steel	Q&T Alloy Steel	Carbon Steel	Stainless Steel
			Heat Treatment	Induction Hardening	Case Hardening	Carburized Induction	Induction Hardening	Induction Hardening	Induction Hardening	Normalizing	Quenched Tempered	Normalizing	Solution	Induction Hardening
Mn	z ⁽¹⁾	dw ⁽⁵⁾	Max. Torque * and Feed-Force											
2	15	31.5	F _{2T} ⁽⁸⁾ (N)	5,333	5,333		5,333	5,333	1,333		1,000	667	2,000	
			T _{2B} ⁽⁹⁾ (Nm)	80	80		80	80	20		15	10	30	
	21	42	F _{2T} ⁽⁸⁾ (N)	7,857	7,857		7,142	7,142	1,190	1,429	952	476	2,381	
			T _{2B} ⁽⁹⁾ (Nm)	165	165		150	150	25	30	20	10	50	
	32	64	F _{2T} ⁽⁸⁾ (N)	8,750	8,750		7,188	7,188	2,188	2,656	1,719	781	2,188	
			T _{2B} ⁽⁹⁾ (Nm)	280	280		230	230	70	85	55	25	70	
3	21	63	F _{2T} ⁽⁸⁾ (N)	15,238	15,238		13,492	13,492	2,698	3,333	2,063	1,111	6,190	
			T _{2B} ⁽⁹⁾ (Nm)	480	480		425	425	85	105	65	35	195	
4	17	68	F _{2T} ⁽⁸⁾ (N)	20,000		20,000	19,559	19,559	7,500	10,294	4,559	2,059	7,647	
			T _{2B} ⁽⁹⁾ (Nm)	680		680	665	665	255	350	155	70	260	
	30	120	F _{2T} ⁽⁸⁾ (N)	29,667		25,500	25,083	25,083	12,333	16,667	7,333	2,167	11,167	
			T _{2B} ⁽⁹⁾ (Nm)	1,780		1,530	1,505	1,505	740	1,000	440	130	670	
5	13	70	F _{2T} ⁽⁸⁾ (N)	28,615	28,615		28,615	28,154	28,154			5,385	2,769	16,615
			T _{2B} ⁽⁹⁾ (Nm)	930	930		930	915	915				175	90
	15	80	F _{2T} ⁽⁸⁾ (N)	34,000	34,000		34,000	33,467	33,467			7,067	3,200	22,800
			T _{2B} ⁽⁹⁾ (Nm)	1,275	1,275		1,275	1,255	1,255				265	120
6	13	84	F _{2T} ⁽⁸⁾ (N)	42,051	42,051		42,051	41,667	41,667			10,256	4,231	31,667
			T _{2B} ⁽⁹⁾ (Nm)	1,640	1,640		1,640	1,625	1,625				400	165

* The Maximal Driving Torque is also to be understood as the Maximal Acceleration Torque T_{2B}.

The Emergency Stop Torque T_{2NOT} = 2 x T_{2B}, under the condition limited 1000 times in the whole service period.

(1) Number of Teeth (5) Working Pitch Circle Diameter (in mm) (8) Maximum Feed-Force (9) Maximum Driving Torque

Pinion with Straight Teeth

(Interface : Long Shaft Pinion without Keyway for Hollow-Shaft)

Quality DIN 5

Tooth Thickness Tolerance : e25

Straight Teeth

Case-Hardened and Teeth Ground

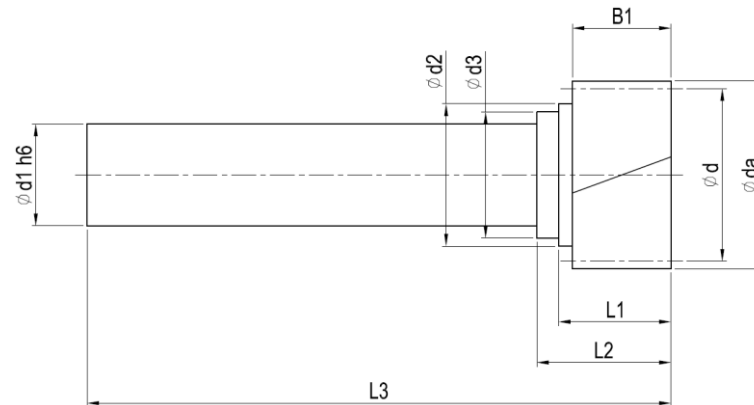

Mn.	z ⁽¹⁾	x ⁽²⁾	da ⁽³⁾	d ⁽⁴⁾	dw ⁽⁵⁾	d1 _{h6}	d2	d3	B1	L1	L2	L3	L ⁽⁶⁾	Order Code
2	15	0.375	35.5	30	31.5	20	24	-	25	31	-	105	94.248	H02115D20
	21	0	46	42	42	25	35	31	25	28.5	34	148	131.947	H02121D25
	32	0	68	64	64	25	38	31	25	28.5	34	148	201.062	H02132D25
	32	0	68	64	64	28	42	36	25	33	38.5	180	201.062	H02132D28
	32	0	68	64	64	36	48	-	25	32.5	-	203	201.062	H02132D36
3	21	0	69	63	63	25	31	-	30	36.5	-	150	197.92	H03121D25
	21	0	69	63	63	28	42	36	30	35.5	41	183	197.92	H03121D28
	21	0	69	63	63	36	48	-	30	37.5	-	208	197.92	H03121D36
4	17	0	76	68	68	28	36	-	40	46	-	188	213.628	H04117D28
	17	0	76	68	68	36	48	-	40	42.5	-	213	213.628	H04117D36
	17	0	76	68	68	48	57	-	40	43.5	-	240	213.628	H04117D48
	30	0	128	120	120	48	57	-	40	43.5	-	240	376.991	H04130D48
5	13	0.5	80	65	70	48	57	-	50	53.5	-	250	204.204	H05113D48
	15	0.5	90	75	80	60	68	-	50	55	-	275	235.619	H05115D60
6	13	0.5	96	78	84	60	68	-	60	65	-	285	245.044	H06113D60

(1) Number of teeth (2) Profile modification factor (3) Diameter of addendum circle (4) Pitch circle diameter

(5) Working pitch circle diameter (6) Pitch circle length $L = \pi \times d$

Pinion with Straight Teeth

(Interface : Long Shaft Pinion without Keyway for Hollow-Shaft)

Quality DIN 5
Tooth Thickness Tolerance : e25
Straight Teeth
Case-Hardened and Teeth Ground

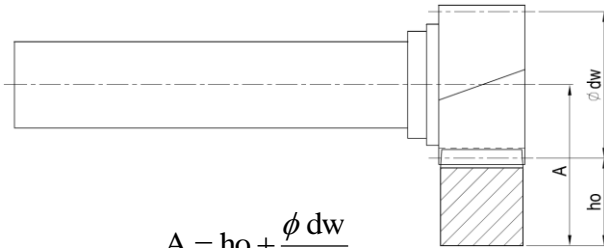
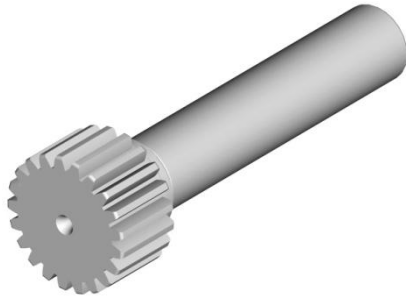

$$A = h_o + \frac{\phi dw}{2}$$

In table 14, the maximum permissible torque of pinion with Long Shaft w/o KW for APEX AF-/ PII - Gearbox, and the rack is calculated on the basis of a speed of 1.5 m/s and providing good lubrication (using an automatic lubrication system or manually applied grease every day), the tooth root strength factor $S_F \geq 1.4$, tooth surface strength coefficient $S_H \geq 1$, the safety factor $S_B \cong 1$, and the required service life of 20,000 hours. By higher speed, the max. permissible torque reduced. The user needs to increase the safety factor for the application. Backlash changes by different center height. Please contact APEX under WWW.APEXDYNA.COM.

Table 14, the max. permitted torque and feed-force of pinion with Long Shaft w/o KW for APEX AF-/ PII-Series

Pinion			Rack											
			Quality	Q4	Q5H	Q5		Q6	Q6M	Q6C	Q8H	Q8	Q9	Q10
			Material	Carbon Steel	Alloy Steel		Carbon Steel	Carbon Steel	Carbon Steel	Carbon Steel	Carbon Steel	Q&T Alloy Steel	Carbon Steel	Stainless Steel
Heat Treatment			Induction Hardening	Case Hardening	Carburized Induction	Induction Hardening	Induction Hardening	Induction Hardening	Normalizing	Quenched Tempered	Normalizing	Solution	Induction Hardening	
Mn	z ⁽¹⁾	dw ⁽⁵⁾	Max. Torque * and Feed-Force											
2	15	31.5	F _{2T} ⁽⁸⁾ (N)		5,333	5,333		5,333	5,333	1,333		1,000	667	2,000
			T _{2B} ⁽⁹⁾ (Nm)		80	80		80	80	20		15	10	30
	21	42	F _{2T} ⁽⁸⁾ (N)		7,857	7,857		7,142	7,142	1,190	1,429	952	476	2,381
			T _{2B} ⁽⁹⁾ (Nm)		165	165		150	150	25	30	20	10	50
	32	64	F _{2T} ⁽⁸⁾ (N)		8,750	8,750		7,188	7,188	2,188	2,656	1,719	781	2,188
			T _{2B} ⁽⁹⁾ (Nm)		280	280		230	230	70	85	55	25	70
3	21	63	F _{2T} ⁽⁸⁾ (N)		15,238	15,238		13,492	13,492	2,698	3,333	2,063	1,111	6,190
			T _{2B} ⁽⁹⁾ (Nm)		480	480		425	425	85	105	65	35	195
4	17	68	F _{2T} ⁽⁸⁾ (N)		20,000		20,000	19,559	19,559	7,500	10,294	4,559	2,059	7,647
			T _{2B} ⁽⁹⁾ (Nm)		680		680	665	665	255	350	155	70	260
	30	120	F _{2T} ⁽⁸⁾ (N)		29,667		25,500	25,083	25,083	12,333	16,667	7,333	2,167	11,167
			T _{2B} ⁽⁹⁾ (Nm)		1,780		1,530	1,505	1,505	740	1,000	440	130	670
5	13	70	F _{2T} ⁽⁸⁾ (N)	28,615	28,615		28,615	28,154	28,154			5,385	2,769	16,615
			T _{2B} ⁽⁹⁾ (Nm)	930	930		930	915	915			175	90	540
	15	80	F _{2T} ⁽⁸⁾ (N)	34,000	34,000		34,000	33,467	33,467			7,067	3,200	22,800
			T _{2B} ⁽⁹⁾ (Nm)	1,275	1,275		1,275	1,255	1,255			265	120	855
6	13	84	F _{2T} ⁽⁸⁾ (N)	42,051	42,051		42,051	41,667	41,667			10,256	4,231	31,667
			T _{2B} ⁽⁹⁾ (Nm)	1,640	1,640		1,640	1,625	1,625			400	165	1,235

* The Maximal Driving Torque is also to be understood as the Maximal Acceleration Torque T_{2B}.

The Emergency Stop Torque T_{2NOT} = 2 x T_{2B}, under the condition limited 1000 times in the whole service period.

(1) Number of Teeth (5) Working Pitch Circle Diameter (in mm) (8) Maximum Feed-Force (9) Maximum Driving Torque

Accessory

Shrink Disc for Pinion with Keyway

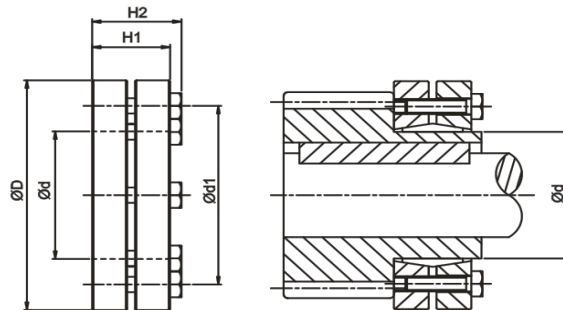

d	dI	D	H1	H2	Screw ⁽¹⁾	T _A ⁽²⁾	J	Order code
					No. x Type	Nm	Kg.cm ²	Stainless Steel
30	44	60	21.5	25	7 x M5	4	1.7	SSD-30
36	52	72	23.5	27.5	5 x M6	12	3.9	SSD-36
44	61	80	25.5	29.5	7 x M6	12	6.4	SSD-44
50	70	90	27.5	31.5	8 x M6	12	11.2	SSD-50
55	75	100	30.5	34.5	8 x M6	12	18.3	SSD-55
62	86	110	30.5	34.5	10 x M6	12	26.5	SSD-62
68	86	115	30.5	34.5	10 x M6	12	30.9	SSD-68
80	100	145	32.5	38	7 x M8	30	86.8	SSD-80
110	145	185	50	57	9 x M10	59	349.6	SSD-110
125	160	215	54	61	12 x M10	59	672.4	SSD-125

(1) 10.9 Class, DIN 931 (2) Tightening Torque

Diameter	Tolerance
≤ 30	H6 / j6
> 30 ~ 50	H6 / h6
> 50 ~ 80	H6 / g6

Accessory

Pin Gauge

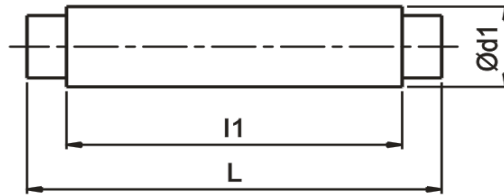

Mn	d _l	l _l	L	Order Code
1	2	-	20	B020
1.5 / 1.75 / 1.591 (Pitch 5)	3	16	20	B030
2	4.2	20	28	B042
2.5 / 3	5	25	33	B050
4 / 3.183 (Pitch 10) / 4.244 (Pitch 13.33)	7	30	40	B070
4.5 / 5	9	34	42	B090
6	10	35	43	B100
8	14	35	45	B140
10	18	35	42	B180
12	20	43	50	B200

Position Pin



Mn	d _l m6	d ₂	t ₁	L	Order Code
1 / 1.5 ($B \leq 17$)	6	M4	6	24	PIN-06-L024
1.5 / 1.75	6	M4	6	28	PIN-06-L028
2	6	M4	6	30	PIN-06-L030
2	8	M5	8	30	PIN-08-L030
2.5 / 3 / 3.183 (Pitch 10)	8	M5	8	40	PIN-08-L040
3	12	M6	12	45	PIN-12-L045
4	8	M5	8	50	PIN-08-L050
4	10	M6	10	55	PIN-10-L055
4	12	M6	12	55	PIN-12-L055
4	16	M8	16	60	PIN-16-L060
4.5 / 5	12	M6	12	70	PIN-12-L070
5	16	M8	16	70	PIN-16-L070
6	16	M8	16	80	PIN-16-L080
6	20	M10	18	80	PIN-20-L080
8	20	M10	18	100	PIN-20-L100
10	20	M10	18	120	PIN-20-L120
12	20	M10	18	140	PIN-20-L140

Rack Gauge for Installation

Rack Gauge for Installation

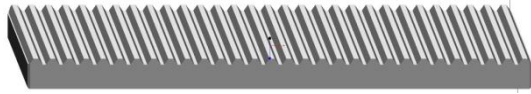

Helical Teeth

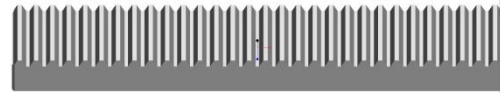

Straight Teeth

Mn	Teeth	L	Teeth No.	$f_p^{(1)}$	$F_p^{(2)}$	Order Code
1	Helical	150	45	0.0035	0.01	RGH01
	Straight	141.37	45			RGS01
1.5	Helical	150	30	0.0035	0.01	RGH1J
	Straight	141.37	30			RGS1J
2	Helical	200	30	0.0035	0.013	RGH02
	Straight	188.49	30			RGS02
2.5	Helical	200	24	0.004	0.014	RGH2J
3	Helical	200	20	0.004	0.014	RGH03
	Straight	188.49	20			RGS03
4	Helical	200	15	0.0045	0.015	RGH04
	Straight	188.49	15			RGS04
5	Helical	200	12	0.0045	0.015	RGH05
	Straight	251.32	16			RGS05
6	Helical	200	10	0.0045	0.015	RGH06
	Straight	245.04	13			RGS06
8	Helical	213.33	8	0.005	0.016	RGH08
	Straight	251.32	10			RGS08
10	Helical	233.3	7	0.005	0.016	RGH10
	Straight	219.91	7			RGS10
12	Helical	280	7	0.006	0.017	RGH12
	Straight	263.89	7			RGS12
1.591 (Pitch 5)	Straight	150	30	0.0035	0.01	RGS1K
3.183 (Pitch 10)	Straight	200	20	0.004	0.014	RGS3B
4.244 (Pitch 13.33)	Straight	213.33	15	0.0045	0.015	RGS4D

(1) f_p = Single Pitch Error (2) F_p = Total Pitch Error

Rack Size according to DIN 867

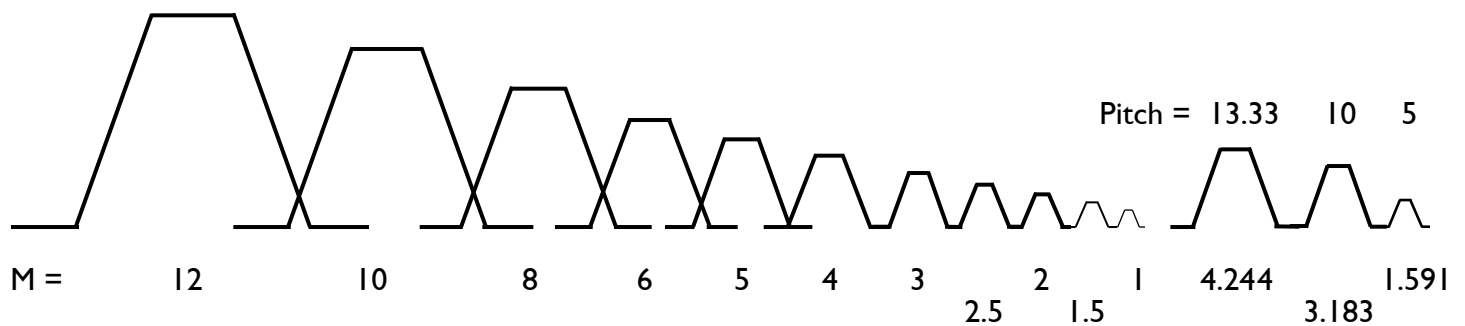

Rack Calculation and Selection

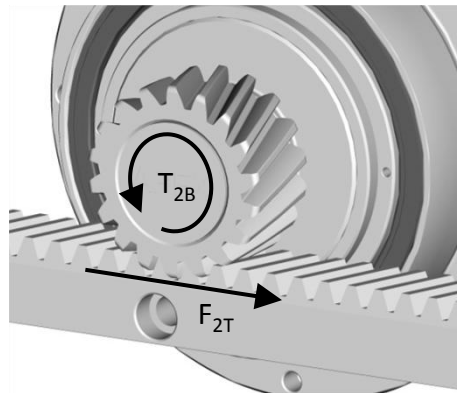

$$F_{2T} = 2 \times T_{2B} / d$$

d : Pitch Circle Diameter

Application		Horizontal handling	Vertical lifting
Unit		Application parameters	
Total load weight	M	Kg	Kg
Speed	V	m/s	m/s
Acceleration time	ta	s	s
Gravitational acceleration	g	9.8 m/s ²	9.8 m/s ²
Friction coefficient	μ	-	-
Pitch circle diameter of pinion	d	mm	mm
Other additional forces	F	N	N
Safety factor	S _B ⁽¹⁾	-	-
		Computational formulas	
		$\alpha = V / ta$ (m/s ²)	$\alpha = V / ta$ (m/s ²)
Tangential force of rack	F _N	$F_N = M \times g \times \mu + M \times a + F$ (N)	$F_N = M \times g + M \times a + F$ (N)
Torque	T _N	$T_N = (F_N \times d) / 2000$ (Nm)	$T_N = (F_N \times d) / 2000$ (Nm)
Design demand torque	T _{NV}	$T_{NV} = T_N \times S_B$ (Nm)	$T_{NV} = T_N \times S_B$ (Nm)
Max. Speed of pinion	N _V	$N_V = (V \times 19100) / d$ (rpm)	$N_V = (V \times 19100) / d$ (rpm)

(1) Please consider the safety factor according to your experience and application, the general recommended range of 1 to 4 (S_B ≐ 1 to 4).

Select a suitable pinion.

Calculate the design demand torque (T_{NV})

To choose T_{2B} (> T_{NV}) according to the table “the max. permitted torque and feed-force of pinion”.

To select the appropriate gearbox and speed ratio to fit the torque.

Refer to APEX Dynamax for a more detailed calculation.

APEX DYNAMICS, INC.

No.10, Keyuan 3rd Road, Situn District, 40763 Taichung City , TAIWAN

Tel : +886-4-24650219 Web : www.apexdyna.com Email : sales@apexdyna.com

2018.06.04



**APEX TAIWAN NORTH
ANDTEK AUTOMATION CO.,LTD**
TEL +886-02-82262655
13F-5, No.2, Jian 8th Rd., Jhonghe Dist., New
Taipei City 235, TAIWAN
sales@andtek.com.tw
www.apexdyna.com



**APEX TAIWAN CENTRAL
ANDTEK AUTOMATION CO.,LTD**
TEL +886-04-23594286
9F-6, No.925, Sec.4, Taiwan Blvd., Xitun Dist.
Taichung City 407 TAIWAN
sales@andtek.com.tw
www.apexdyna.com



**APEX TAIWAN SOUTH
MEN JENN ELECTRIC CO., LTD.**
TEL +886-06-2337332 ~ 6
No.774, Zhonghua Rd., Yongkang Dist., Tainan
City 710, TAIWAN
menjenn@ms24.hinet.net
www.apexdyna.com

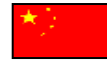

APEX DYNAMICS INC. SHANGHAI
TEL +86-21-69220577
No.128 ZHUYING Road QINGPU Industry Area,
Shanghai, CHINA
sales@apexdyna.cn
www.apexdyna.cn

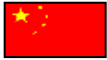

APEX DYNAMICS SHENZHEN, LTD.
TEL +86-755-84516325
No. 1102A of D area , CFG mansion ,Bao Yuan
Road , Bao' an District , Shenzhen ,CHINA.
sales@szapexdyna.com
www.szapexdyna.com

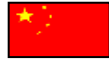

APEX DYNAMICS BEIJING, LTD.
TEL +86-10-69570691
NO.1,YaoPingRoad,SongZhuang Town, Tongzhou
istrict, Beijing, CHINA.
bjapexdyna@163.com
www.bjapex.cn

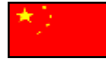

CHONGQING APEX DYNAMICS CO., LTD.
TEL +86-23-67686860
406, Building 5, No.68,Jinyu Avenue, Beibu New
Area, Chongqing, CHINA
sales@cqapexdyna.com
www.apexdyna.com



**APEX (XIAMEN) DYNAMICS TECHNOLOGY CO.,
LTD.**
TEL +86-0592-720-5279
Unit B-3,1F.,No.129,Jingquan Road, Jimei District,
Xiamen, Fujian, CHINA
sales@xmapexdyna.com
www.xmapexdyna.com



APEX DYNAMICS USA, INC.
TEL +1-631-2449040
885 Marconi Avenue Ronkonkoma, NY 11779
U.S.A.
sales@apexdynamicsusa.com
www.apexdynamicsusa.com



APEX DYNAMICS KOREA
TEL +82-31-8179992
1246-32, Seongsuk-dong, Ilsandong-gu, Goyang-
city, Gyeonggi-Do, KOREA (R.O.K) 410-570
sales@apexdynakorea.co.kr
www.apexdynakorea.co.kr



APEX DYNAMICS JAPAN
TEL +81-092-4511202
1-13-3, Sannou, Hakata-ku, Fukuoka-Shi 812-
0015, JAPAN
sales@apexdyna.jp
www.apexdyna.jp



APEX DYNAMICS SINGAPORE PTE LTD
TEL +65-62-626228
3 South Buona Vista Road, #05-15 & #06-15.
SINGAPORE 118136
sales@apexdyna.com.sg
www.apexdyna.com.sg



APEX DYNAMICS (THAILAND) CO., LTD.
TEL +66-2-3266233
73 Soi Ladkrabang 30, Kadkrabang Rd.,Bangkok
10520, THAILAND
sales@apexdyna.co.th
www.apexdyna.co.th



APEX DYNAMICS BV
TEL +31-492-509995
Churchillaan 101 5705 BK Helmond,
NETHERLANDS
sales@apexdyna.nl
www.apexdyna.nl
www.apexdyna.be



**APEX DYNAMICS
POLSKA SP. Z O.O.**
TEL +48-12-6304728
Krakowska 50, 32-083 Balice, POLAND
sales@apexdyna.pl
www.apexdyna.pl



APEX DYNAMICS SPAIN, S.L
TEL +34-93-6562990
Poligono Industrial Molí dels Frares, Calle C nº
12,08620 - Sant Vicenç dels Horts, Barcelona,
SPAIN
apexdyna@apexdyna.es
www.apexdyna.es



APEX DYNAMICS IRAN.
TEL +98-21-66593517
APT#6, 3rd Flr, No.5, 3rd Kowsar St., Sattarkhan
Ave., Tehran, IRAN
alahyari@farasysco.com
www.apexdyna.ir



APEKS REDUKTOR VE DISLI SAN. TIC. LTD. STI.
TEL +90-232-4589960
10042 Sok.No:10 AOSB Çiğli-İzmir, TURKEY
sales@apexdyna.com.tr
www.apexdyna.com.tr



APEX DYNAMICS AUSTRALIA PTY LTD.
TEL +613-95-852739
36 Taunton Drive, Cheltenham, Victoria 3192
AUSTRALIA.
sales@apexdyna.com.au
www.apexdyna.com.au



APEX DYNAMICS (I) JV
TEL +91-80-55345541
GAT NO. 279, KHED SHIVAPUR BAUG, TALUKA
HAVELI PUNE- 412205 INDIA.
sales@apexdyna.co.in
www.apexdyna.co.in



APEX DYNAMICS FRANCE SAS
TEL +33-160-135097
11 - Burospace F - 91570 -
Bièvres, FRANCE
info@apexdyna.fr
www.apexdyna.fr



APEX DYNAMICS SWEDEN AB
TEL +46-75-2424444
Fredrikbergsgatan 2 SE-573 92 Tranås, SWEDEN
sales@apexdyna.se
www.apexdyna.se



PT.APEX DYNAMICS INDONESIA
TEL +62 21 2928 3681
Rukan Aralia Blok HY43 no.11, Harapan Indah II,
Bekasi - Jawa Barat, INDONESIA 17214
sales@apexdyna.co.id
www.apexdyna.co.id



APEX DYNAMICS GERMANY GMBH
TEL +49-7181-9329955
Spanninger Str. 9, 73650 Winterbach, GERMANY
Langer@apexdynamics.de
www.apexdynamics.de



APEX DYNAMICS CZECH S.R.O.
TEL +420-577-663877
tř. Tomáše Bati 1851 765 02 Otrokovice ČESKÁ
REPUBLIKA
info@apexdynaczech.cz
www.apexdynaczech.cz



APEX DYNAMICS РОССИЯ
TEL +7-495-2255452
+7-495-6462422
г.Москва, ул. Южнопортовая, дом 7, строение
“С”, 3-й этаж
info@apexdynarussia.ru
www.apexdynarussia.ru



APEX DYNAMICS UK LIMITED
TEL +44-1827-253340
2 Centurion Way, Centurion Park, Tamworth
Staffs, B77 5PN, UK
sales@apexdynamicsuk.com
www.apexdynamicsuk.com



APEX DYNAMICS SWITZERLAND AG
TEL +41-55-4517020 Talstrasse 24, CH-8852
Altendorf, SWITZERLAND
info@apexdyna.ch
www.apexdyna.ch



APEX DYNAMICS MOTION SDN BHD TEL +60
7237 1055
No.1, Jalan Perniagaan Setia 3, Taman
Perniagaan Setia, 81100 Johor Bahru, Johor,
MALAYSIA (Setia Business Park 2 @ Iskandar
Malaysia)
sales@apexdyna.com.sg
www.apexdyna.com.sg



APEX DYNAMICS BRAZIL
TEL +55-47-30298700
Rua Senador Petrônio Portela, 47 - Bloco 5, Zona
Industrial Norte - CEP 89218-575 - Joinville (SC)
luacan@neoyama.com.br
adriano.duarte@neoyama.com.br
www.neoyama.com.br



APEX DYNAMICS ITALY
TEL +39 02.36634521
VIA E. DE AMICIS, 2 – 20091 BRESSO (MI)
info@apexdynamics.it
www.apexdynamics.it